

# APCO AVR 1500A/1500AC VACUUM RELIEF/AIR INLET VALVES

## APCO AVR Vacuum Relief/Air Inlet Valves

APCO AVR 1500A Vacuum Relief/Air Inlet Valves are proven reliable at preventing vacuum formation in pipelines and resulting damage from column separation and water hammer (pressure surges). They are normally closed, large orifice one-way valves. They permit air to enter the pipeline or system to break a vacuum, but no air escapes when the system pressure returns to positive. They are available in sizes 3-24" (80-600mm) and are recommended for either water or sewage applications.

The AVR is also available as a 1500AC Combination Valve, with the large orifice Vacuum Relief/Air Inlet Valve opening quickly to prevent a vacuum while the small orifice Air Release Valve regulates a slow discharge of air from the pipeline.

## Quality Construction for Maximum Service Life

Vacuum Relief/Air Inlet Valves are normally shut for prolonged periods of time, and often not readily accessible for inspection. Therefore, it is critically important to select a reliable, high quality valve. The APCO AVR Vacuum Relief/Air Inlet Valve consists of the highest quality components: body, cover, plug, seat, stainless steel spring, and a hood or cap to prevent debris from entering the valve.

## Body Design & Materials

The ruggedly constructed globe type body has integrally cast flanged ends in ASME 125/150 and ASME 250/300 (3-12"); 80-300mm pressure classes. The Vacuum Relief/Air Inlet Valve is cast ductile iron; for more demanding applications, carbon steel or 316 stainless steel bodies are available. Ductile iron bodies are flat faced as standard; carbon steel and stainless steel are raised face as standard.

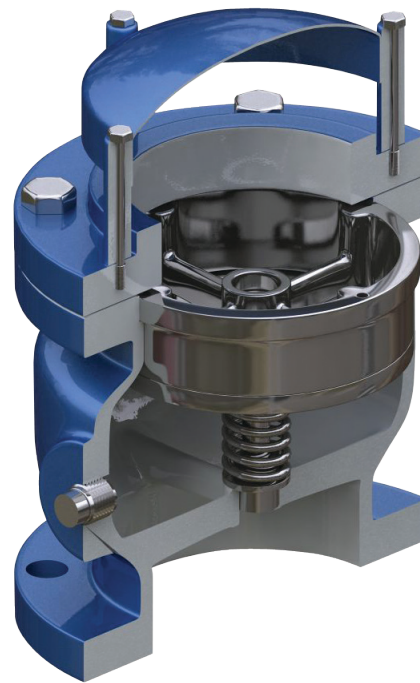

## All Stainless Steel Internal Parts for Durability

The internal valve plug and seat are 316 stainless steel for durability and corrosion resistance. The plug is center guided on both ends to provide drop tight shut-off and prevent jamming. The plug is held in the normally closed position by a precisely coiled and annealed stainless steel spring and bushing.

## Fully Retained Resilient Seat

The resilient seat is retained in the body by the cover. The seat is designed to prevent distortion and provide positive shut-off. Resilient seat options include Acrylonitrile-Butadiene (NBR), Ethylene Propylene & A Diene (EPDM) and Fluoro Rubber (FKM).

## Hood Options Prevent Debris

The Vacuum Relief/Air Inlet Valve has a steel hood to prevent debris entering on sizes 6-24" (150-600mm) and a mushroom cap on sizes 3" & 4" (80 & 100mm). Optional bug or rock screens are available.

## Reliable Vacuum Prevention

The Vacuum Relief/Air Inlet Valve is normally closed. Should the system pressure become negative, the Vacuum Relief/Air Inlet Valve will immediately admit air into the system and prevent a vacuum from forming. When system pressure returns to positive, the Vacuum Relief/Air Inlet Valve closes air tight.

The valve has a cross-sectional inflow area that is 10% greater than equivalent pipe size for full vacuum relief protection during draining, pipeline rupture or water column separation. Standard Vacuum Relief/Air Inlet Valves are designed to open with a minimal 0.25 psi (2 kPa) pressure differential across the orifice. Higher or lower relief settings are available on application.

## Pipeline Protection Made Simple

Vacuum Relief/Air Inlet Valves are installed at high points on a pipeline or a tank. They can also be installed at level points on a pipeline where it has been determined a vacuum may occur. A vacuum condition can be sufficient to collapse a thin wall pipeline or a sealed water tank.

Vacuum conditions cause water column separation to take place resulting in water hammer (pressure surge) when the water column rejoins. The severity of damage due to water column separation and resulting pressure surges in a pipeline when the column rejoins, will generally cause greater damage than the initial vacuum condition. To prevent damage from water hammer, a large orifice Vacuum Relief/Air Inlet Valve can be combined with a small orifice Air Release Valve as a Combination Valve.

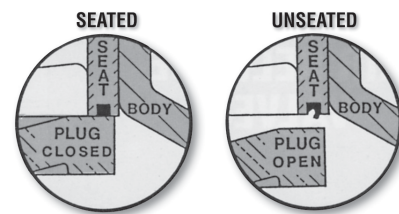
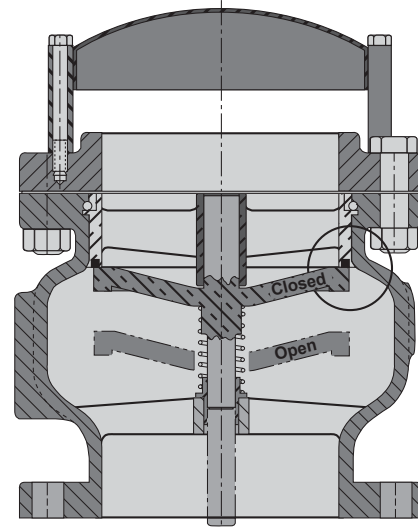

## Combination Vacuum Relief/Air Inlet and Air Release Valves

The large orifice Vacuum Relief/Air Inlet Valve can be combined with a small orifice Air Release Valve to prevent damage from water hammer.

When installed at points where water column separation is anticipated, the large valve will open due to vacuum, admitting air into the pipeline which fills the void created by water separation. It will then instantly close, trapping air which will be compressed and act like brakes to slow down the rejoining water column and minimize severe pressure surge as system pressure returns to positive. Meanwhile, the small orifice Air Release Valve has also opened due to vacuum and stays open regulating a slow discharge of air from the pipeline to enable a gradual return to normal pipeline system operating pressure without damage.

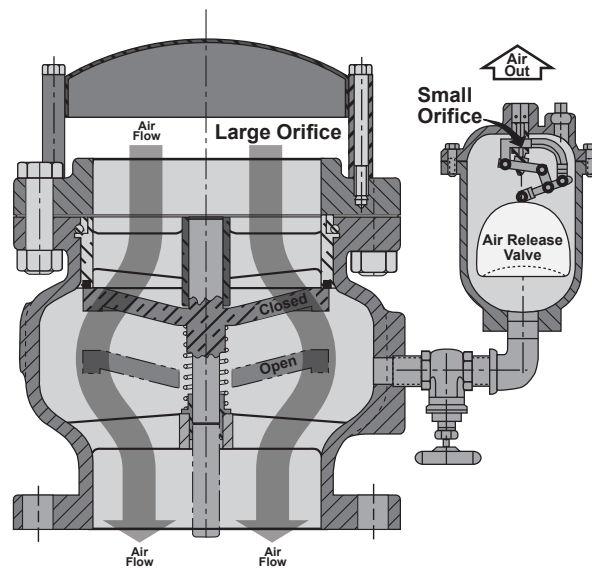

When installed at points where water column separation is anticipated, the large valve will open due to vacuum, admitting air into the pipeline which fills the void created by water separation. It will then instantly close, trapping air which will be compressed and act like brakes to slow down the rejoining water column and minimize severe pressure surge as system pressure returns to positive. Meanwhile, the small orifice Air Release Valve has also opened due to vacuum and stays open regulating a slow discharge of air from the pipeline to enable a gradual return to normal pipeline system operating pressure without damage.

# Materials of Construction

Item	Description	Material
S01	Body	Ductile Iron, ASTM A536
		Carbon Steel, ASTM A216
		316 Stainless Steel, ASTM A743, A351
S02	Seat	316 Stainless Steel, ASTM A743, A351
S03	Plug	317 Stainless Steel, ASTM A743, A351
S04	Spring	316 Stainless Steel, ASTM A313
S05	Bushing	316 Stainless Steel, ASTM A240
S06	Seat Retaining Ball	440 Stainless Steel
S07	Seat Retaining Screw	18-8 Stainless Steel or 316 Stainless Steel
S08	Resilient Seat	Acrylonitrile-Butadiene (NBR)
		Terpolymer of Ethylene Propylene & A Diene (EPDM)
		Fluoro Rubber (FKM)
S11	Bushing Retaining Ring	15-7PH Stainless Steel, ASTM A564, A693
S19	Flange Gasket	Cellulose Cork Fiber, Non-Asbestos
S20	Flange Nut	Carbon Steel, Zinc Plated
		316 Stainless Steel
S21	Flange Screw	Carbon Steel, Zinc Plated
		316 Stainless Steel
S23	Mushroom Cap (3 & 4"); Hood (6-36")	Steel, Wrought
		316 Stainless Steel
S24	Hood Screw	Carbon Steel, Zinc Plated
		316 Stainless Steel
S25	Flange	Steel, Forged
		316 Stainless Steel
S27	Washer	Carbon Steel, Zinc Plated
		316 Stainless Steel
S28	Screen (Optional - not pictured)	304 Stainless Steel

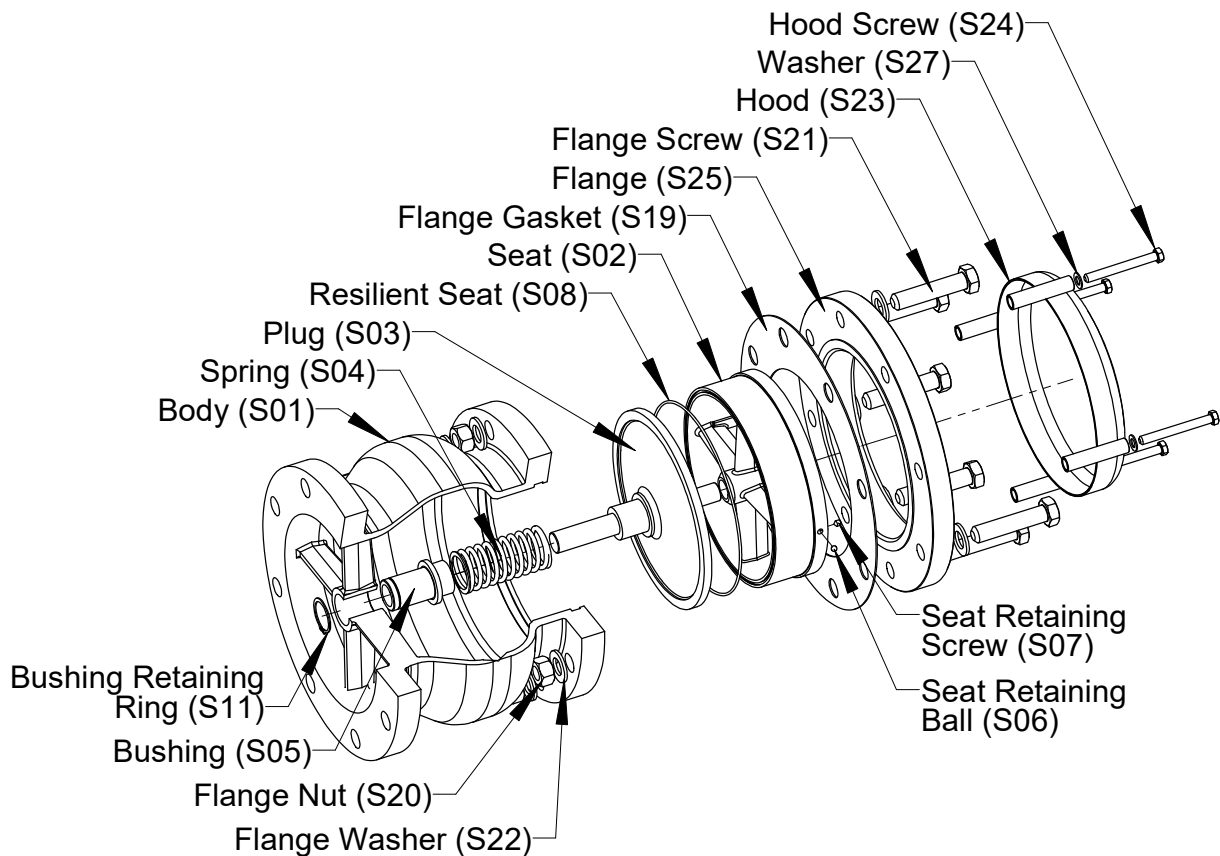

## Applicable Standards

APCO AVR-1500A Vacuum Relief/Air Inlet Valves are designed and/or tested to meet the following standards:	
AWWA C550	Protective Interior Coatings for Valves and Hydrants
ASME B16.5	ASME Class 150 (F1) & ASME Class 300 (F2) flanged valves made from carbon steel or stainless steel
ASME B16.42	ASME Class 150 (F1) & ASME Class 300 (F2) flanged valves made from ductile iron

# Valve Selection

## Vacuum Relief/Air Inlet Valve Pressure Ratings (at ambient temperature)

Body Material	Maximum Differential Pressure	
	F1 (Class 125/150)	F2 (Class 250/300)
Ductile Iron	250 psi (1720 kPa)	640 psi (4410 kPa)
Carbon Steel	285 psi (1960 kPa)	450 psi (3100 kPa)
316 Stainless Steel	275 psi (1900 kPa)	425 psi (2930 kPa)

## Temperature Ratings

Material	Temperature Range*
NBR, Acrylonitrile-Butadiene	-70 to 250° F (-57 to 121° C)
EPDM, Terpolymer of Ethylene Propylene & A Diene	-20 to 300° F (-29 to 150° C)
FKM, Fluoro Rubber	-40 to 425° F (-40 to 218° C)

\*Maximum operating temperature is a function of the materials used in the valve.  
 All valves are rated to a maximum temperature of at least 250° F (121° C).  
 Contact application engineering if the valve is required to operate above 250° F (121° C).

## Performance Graphs

Inflow curves shown are actual flow capacities at 14.7 psi barometric pressure and at 70°F temperature. Values are given as a guide of what can be expected under specific flow conditions. These values approximate capacities and therefore data shown can be used for general application of the Vacuum Relief/Air Inlet Valves.

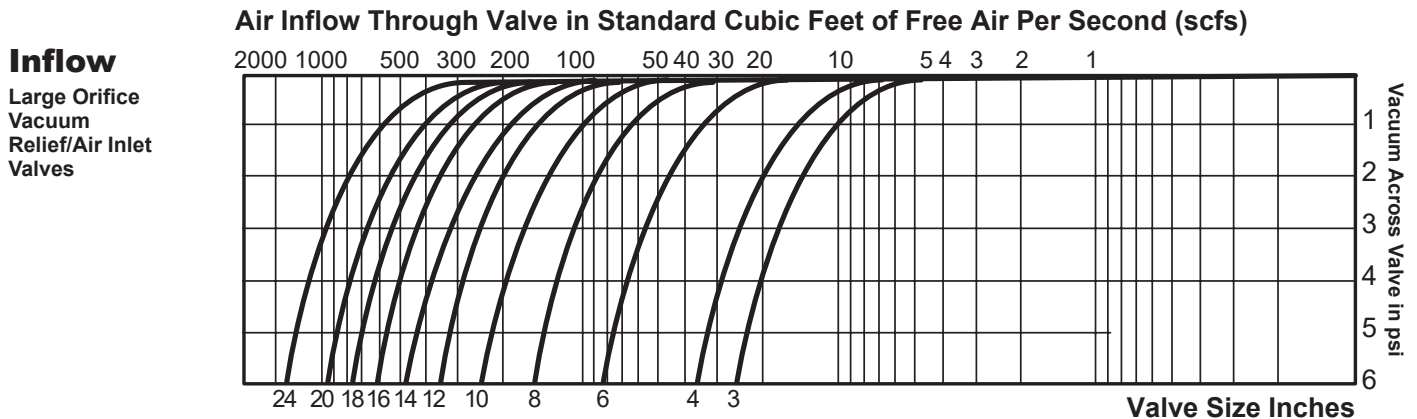

## Outflow

Small Orifice Air Release Valves

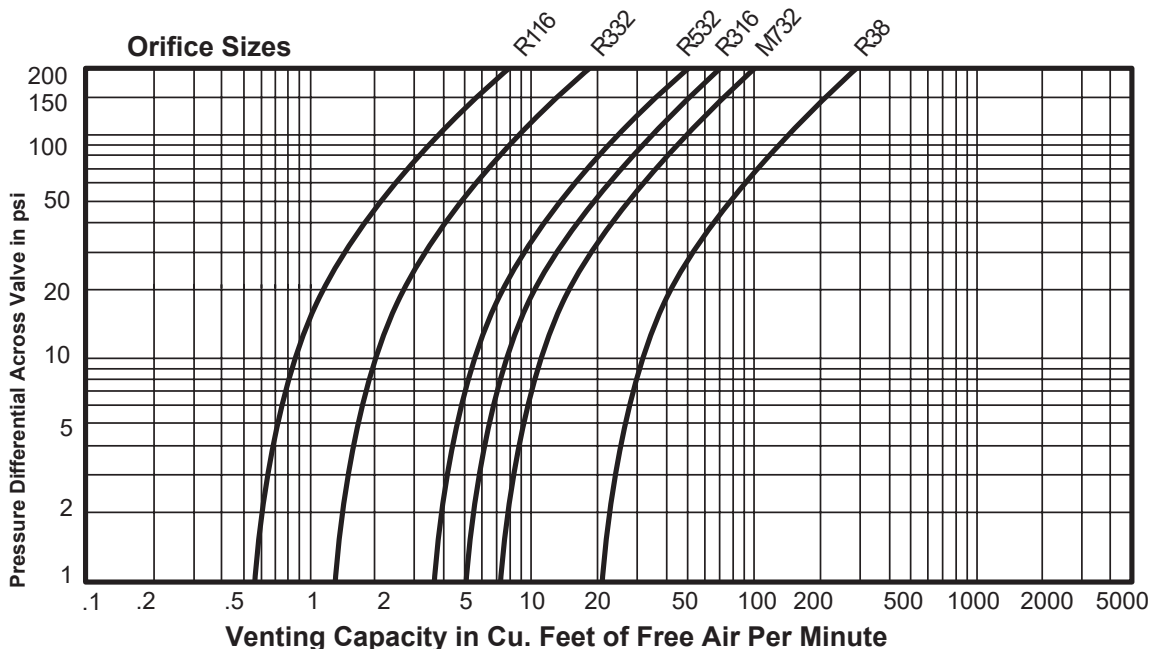

# Valve Selection (cont.)

## Combination Valve 1500AC

### Air Release Valve Pressure Ratings (ambient temperature)

Body Style	Orifice Order Code	Orifice Diameter	Valve Minimum Rated Pressure (psi)	Valve Maximum Rated Pressure (psi)	Venting Capacity (CFFAM)
50A	R332	3/32"	8	175	18
	R116	1/16"	11	300	12
200A	R316	3/16"	11	150	60
	R532	5/32"	11	300	75
200	R38	3/8"	51	150	250
	M732	7/32"	51	300	150

Limiting factor for Working Pressure is the lowest pressure rating of the end connection, valve rated pressure and orifice pressure rating.

## Valve Weights

Valve Size	ASME Class 125/150 (F1)				ASME Class 250/300 (F2)			
	1500A	1500AC			1500A	1500AC		
		50A	200A	200		50A	200A	200
3" 80mm	40 18	46 21	85 39	60 28	52 24	58 27	97 45	72 34
4" 100mm	55 25	61 28	100 46	75 35	83 38	89 41	128 59	103 48
6" 150mm	88 40	94 43	133 61	108 50	133 60	139 63	178 81	153 70
8" 200mm	136 62	142 65	181 83	156 72	224 102	230 105	269 123	244 112
10" 250mm	244 111	250 114	289 132	264 121	357 162	363 165	402 183	377 172
12" 300mm	350 159	356 162	395 180	370 169	505 229	511 232	550 250	525 239
14" 350mm	477 216	483 219	522 237	497 226	-	-	-	-
16" 400mm	595 270	601 273	640 291	615 280	-	-	-	-
18" 450mm	706 320	712 323	751 341	726 330	-	-	-	-
20" 500mm	905 411	911 414	950 432	925 421	-	-	-	-
24" 600mm	1275 578	1281 581	1320 599	1295 588	-	-	-	-

lbs  
kg

## Accessories

### Mushroom Cap (MRC)

A Mushroom Cap prevents foreign debris from entering the air release valve outlet while providing wide openings for free expulsion of air. Available on all Air Release Valve orifice sizes. To order as part of a complete valve, add MRC to order code.

### Ordering Example:

AVR,8,1500AC,F1,DI,S2-NBR,R332\*MRC

### Adjustable Vacuum Relief (ADJ)

An Adjustable Vacuum Relief with a 0 to 5 psi negative pressure/ vacuum setting is available as an option on 3-12" AVR Vacuum Relief/ Air Inlet Valves. To order as part of a complete valve, add ADJ to the order code. Contact DeZURIK's application engineers with pressure range and include set point as second line information.

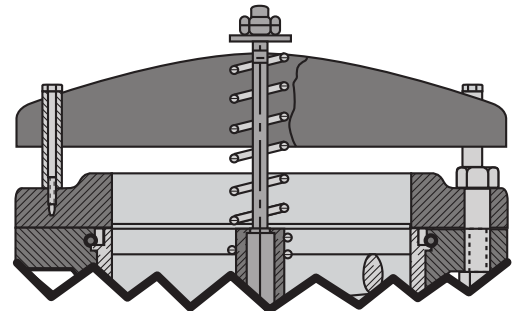

### Ordering Example:

AVR,8,1500A,F1,DI,S2-NBR\*ADJ

# Ordering

To order, simply complete the valve order code from information shown. An ordering example is shown for your reference.

<b>Valve Style</b> Give valve style code as follows:	
AVR	= Vacuum Relief/Air Inlet Valves

<b>Valve Size</b> Give valve size code as follows:			
3	= 3" 80mm	14	= 14" 350mm
4	= 4" 100mm	16	= 16" 400mm
6	= 6" 150mm	18	= 18" 450mm
8	= 8" 200mm	20	= 20" 500mm
10	= 10" 250mm	24	= 24" 600mm
12	= 12" 300mm		

<b>Body Style</b> Give body style code as follows:	
1500A	= Flanged, with Cap 3" & 4"; with Steel Hood 6-24"
1500AC	= Combination Valve, Flanged, with Cap 3" & 4"; with Steel Hood 6-24" and Air Release Valve

<b>End Connection</b> Give end connection code as follows:	
F1	= Flanged ASME 125/150 (3-24")
F2	= Flanged ASME 250/300 (3-12")

<b>Body Material</b> Give body material code as follows:	
DI	= Ductile Iron
CS	= Carbon Steel
S2	= 316 Stainless Steel

<b>Cold Working Pressure</b> Give working pressure code as follows:	
<b>Body Style 1500AC</b>	
NA	= Not Required
<b>Body Style 1500A</b>	
15	= 3-18" 0-15 psi, all body materials
125	= 3-12" 0-200 psi, DI body material
400A	= 14-18" 0-150 psi, DI body material
	= 3-12" 0-400 psi, DI body material
	= 14-18" 0-300 psi, DI body material
	= 3-12" 0-425 psi, S2 body material
	= 14-18" 0-350 psi, S2 body material
	= 3-12" 0-450 psi, CS body material
150	= 14-18" 0-350 psi, CS body material
	= 3-18" 0-250 psi, DI body material
	= 3-18" 0-275 psi, S2 body material
Note:	20" & 24" available on application
	Working pressure is de-rated at temperatures over 100° F.

<b>Trim Combination</b> <b>Plug &amp; Seat Material</b> Give plug & seat material code as follows:	
S2	= 316 Stainless Steel

<b>Seating Surface</b> Give seating surface material code as follows:	
NBR	= Acrylonitrile-Butadiene
EPDM	= Terpolymer of Ethylene Propylene & A Diene
FKM	= Fluoro Rubber

<b>Air Release Valve</b> Give air release valve code as follows:	
<b>Body Styles 1500A</b>	
	= Not Required (leave field blank)
<b>Body Style 1500AC</b>	
R332	= ARV,1,50A,T1,_R332-_-S2-S2-S2* 8-175 psi
R116	= ARV,1,50A,T1,_R116-_-S2-S2-S2* 11-300 psi
R316	= ARV,1,200A,T1,_R316-_-S2-S2-S2* 11-150 psi
R532	= ARV,1,200A,T1,_R532-_-S2-S2-S2* 11-300 psi
R38	= ARV,2,200,T1,_R38-_-S2-S2-S2* 51-150 psi
M732	= ARV,2,200,T1,_M732-_-S2-S2-S2* 51-300 psi

<b>Options</b> Give option code as follows if required:	
----	= Coatings, contact factory
DTR	= DeZURIK Standard Certified Production Hydrostatic Shell and Seat Test Report
HSB	= Bug Screen for Hood, 304 Stainless Steel (6-24")
HSR	= Rock Screen for Hood, 304 Stainless Steel (6-24")
SB16	= 316 Stainless Steel Bolting

<b>Accessories</b> Give accessory code as follows if required:	
ADJ	= Adjustable Vacuum Relief (3-12")
	<b>Note:</b> Pressure range must be specified in a modifier and the set point as 2nd line information on the order. (0 to 5 psi negative pressure/vacuum setting - lower settings available)
MRC	= Mushroom Cap, Galvanized, 1 cap for Air Release Valve

**Ordering Examples:**  
 AVR,8,1500A,F1,DI125,S2-NBR,HSB\*  
 AVR,8,1500AC,F1,DI,S2-NBR,R332,HSB\*MRC

NOTE: Maximum operating temperature is a function of the materials used in the valve. All valves are rated to a maximum temperature of at least 250° F (121° C). Contact application engineering if the valve is required to operate above this temperature.

Ductile iron bodies have flat faced flanges as standard. Carbon steel and stainless steel are raised face as standard.



# Dimensions

## Body Style 1500A

Flanged, ASME 125/150 (F1)

Valve Size	A	B	C	D	H
3" 80mm	7.50 191	11.00 279	3.25 83	0.94 24	-
4" 100mm	9.00 229	12.50 318	4.13 105	0.94 24	-
6" 150mm	11.00 279	14.00 356	5.63 143	1.00 25	-
8" 200mm	13.50 343	15.63 397	7.00 178	1.13 29	-
10" 250mm	16.00 406	18.00 457	9.06 230	1.19 30	0.31 8
12" 300mm	19.00 483	20.75 527	10.38 264	1.25 32	0.31 8
14" 350mm	21.00 533	23.00 584	12.00 305	1.38 35	-
16" 400mm	23.50 597	27.50 699	13.31 338	1.44 37	0.69 18
18" 450mm	25.00 635	28.50 724	15.19 386	1.56 40	1.38 35
20" 500mm	27.50 699	30.50 775	16.75 425	1.69 43	1.13 29
24" 600mm	32.00 813	36.00 914	19.00 483	1.88 48	2.25 57

Flanged, ASME 250/300 (F2)

Valve Size	A	B	C	D	H
3" 80mm	8.25 210	11.00 279	3.25 83	1.13 29	-
4" 100mm	10.00 254	12.50 318	4.13 105	1.25 32	-
6" 150mm	12.50 318	14.75 375	5.63 143	1.44 37	-
8" 200mm	15.00 381	16.13 410	7.00 178	1.63 41	-
10" 250mm	17.50 445	18.75 476	9.06 230	1.88 48	0.31 8
12" 300mm	20.50 521	21.20 538	10.38 264	2.00 51	0.31 8

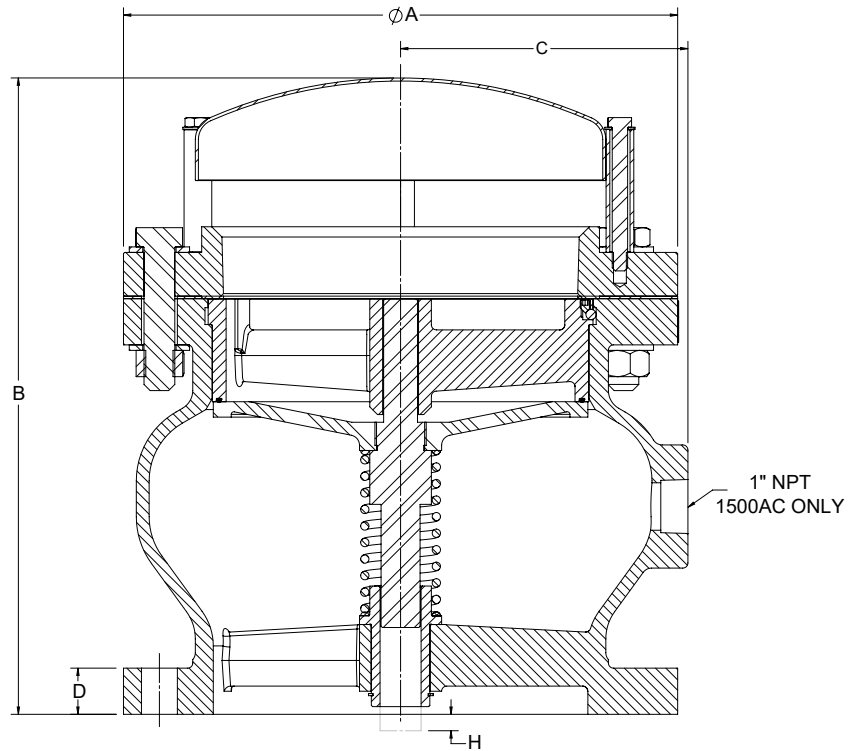

# Dimensions

## Combination Air Valve Body Style 1500AC

Valve Size	ASME 125/150 (F1) End Connection		ASME 250/300 (F2) End Connection		C	ARV 50A Air Release Valve		ARV 200 Air Release Valve		ARV 200A Air Release Valve	
	A	B	A	B		D	E	D	E	D	E
	3" 80mm	11.00 279	3.75 95	11.00 279		4.13 105	2.75 70	11.25 286	10.69 272	13.44 341	17.94 456
4" 100mm	12.50 318	4.50 114	12.50 318	5.00 127	3.69 94	12.13 308	11.31 287	14.31 363	18.56 471	13.00 330	15.44 392
6" 150mm	14.00 356	5.47 139	14.75 375	6.22 158	4.31 109	13.63 346	12.19 310	15.81 402	19.44 494	14.50 368	16.31 414
8" 200mm	15.63 397	6.75 171	16.13 410	7.50 191	6.56 167	15.00 381	12.75 324	17.19 437	20.00 508	15.88 403	16.88 429
10" 250mm	18.00 457	8.00 203	18.75 476	8.75 222	6.75 171	17.06 433	13.69 348	19.25 489	20.94 532	17.94 456	17.81 452
12" 300mm	20.75 527	9.50 241	21.50 546	10.25 260	10.06 256	18.38 467	14.88 378	20.56 522	22.13 562	19.25 489	19.00 483
14" 350mm	23.00 584	10.50 267	-	-	11.25 286	20.00 508	15.56 395	22.19 564	22.81 579	20.88 530	19.69 500
16" 400mm	27.50 699	11.75 298	-	-	12.69 322	21.31 541	16.50 419	23.50 597	23.75 603	22.19 564	20.63 524
18" 450mm	28.50 724	12.50 318	-	-	13.88 353	23.19 589	17.06 433	25.38 645	24.31 617	24.06 611	21.19 538
20" 500mm	30.50 775	13.75 349	-	-	15.56 395	24.75 629	18.00 457	26.94 684	25.25 641	25.63 651	22.13 562
24" 600mm	36.00 914	16.00 406	-	-	18.50 470	27.00 686	19.69 500	29.19 741	26.94 684	27.88 708	23.81 605

inches  
millimeters

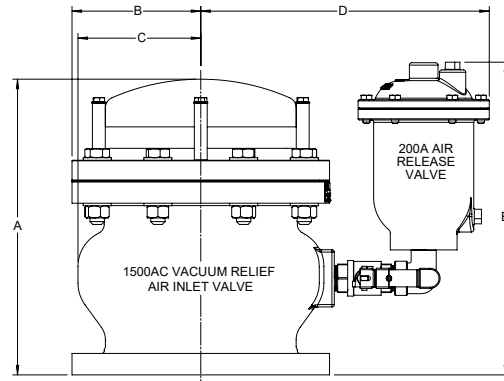
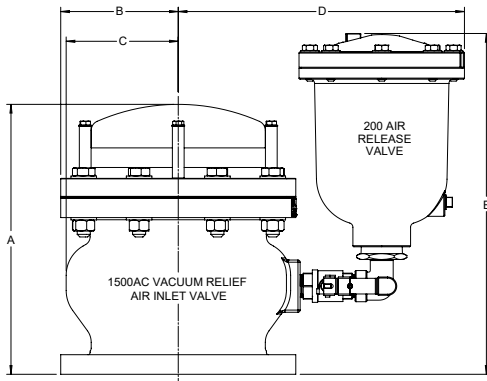
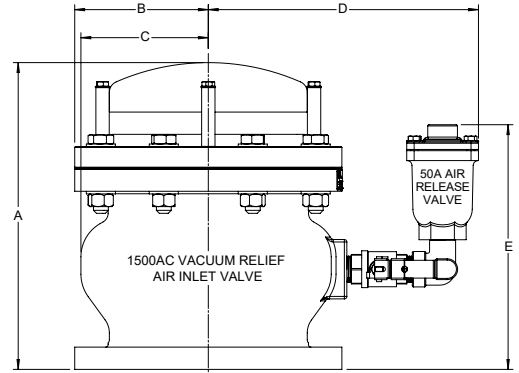

### Sales and Service

For information about our worldwide locations, approvals, certifications and local representative:

Web Site: [DeZURIK.com](http://DeZURIK.com) E-Mail: [info@DeZURIK.com](mailto:info@DeZURIK.com)



250 Riverside Ave. N. Sartell, Minnesota 56377 • Phone: 320-259-2000 • Fax: 320-259-2227

*DeZURIK, Inc. reserves the right to incorporate our latest design and material changes without notice or obligation. Design features, materials of construction and dimensional data, as described in this bulletin, are provided for your information only and should not be relied upon unless confirmed in writing by DeZURIK, Inc. Certified drawings are available upon request.*