

DeZURIK COMPAK CYLINDER ACTUATORS

Design & Construction

Compak actuators are a versatile rack and pinion design for use on 1/2-3" (15-80mm) PEC Eccentric Plug Valves, 1 1/2-6" (40-150mm) BOS-CL butterfly valves, and 2-8" (50-200mm) BHP High Performance Butterfly Valves. The compact, modular design allows the actuator to be mounted for a low profile assembly.

Wide Torque Range

Compak actuators are available in sizes to meet a wide variety of torque requirements. Double-acting units start at 350 in lbs. (39.5 nm) and go up to 35,000 in lbs. (3954.5 nm) of output torque at 80 psi (1650 kPa). Fail-safe, spring return models have output torque from 150 in lbs. (16.9 nm) to 16,000 in lbs. (1808 nm). Compak actuators are matched to each valve's torque requirements to ensure the most economical valve and actuator package is specified.

Enclosed Construction

Compak actuators are environmentally shielded to protect internal parts from grit, moisture and corrosive contaminant. The actuator body is extruded, machined, anodized internally and externally for maximum internal and external protection.

Maximum Cycle Life

Compak pistons are aluminum and the pinion is nickel plated alloy steel. Both pistons incorporate a large wear band which significantly increases cycle life. Upper and lower bushings minimize wear and increase actuator duty cycle.

Adjustable Limit Stops

Each unit incorporates field adjustable double limit stops for precise positioning. The double limit stops allow for stop adjustment in both directions of travel and extend valve life.



Accessory Options

Compak actuators are available with all DeZURIK standard accessory options including positioners, solenoids, mechanical and proximity switches, air filter regulators and speed controls.

Materials of Construction

Item	Description	Material
A1	Indicator Cap Screw	Plastic/Stainless Steel
A2	Position Indicator	Plastic (ABS)
A3	Pinion Snap Ring	Stainless Steel 300 Series
A4	Thrust Washer	Stainless Steel 300 Series
A5	Thrust Bearing	Polyoxymethylene
A6	Body	Extruded Aluminum Alloy
A7	Piston Guide	Polyoxymethylene
A8	O-Ring (Pinion Top)	Buna "N" (standard)
A9	Bearing (Pinion Top)	Polyoxymethylene
A10	Inside Washer	Polyoxymethylene
A11	Stroke Adjustment Stop	Alloy Steel
A12	Pinion (Drive Shaft)	Nickel Plated Alloy Steel
A13	Bearing (Pinion Bottom)	Polyoxymethylene
A14	O-Ring (Pinion Bottom)	Buna "N" (standard)
A15	Spring (Cartridge)	Spring Steel (Corrosion Resistant)
A16	Bearing (Piston)	Polyoxymethylene
A17	O-Ring (Piston)	Buna "N" (standard)
A18	Piston	Aluminum
A19	Plug	NBR
A20	O-Ring (Adjust Screw)	Buna "N" (standard)
A21	Stop Nut (Adjust Screw)	Stainless Steel 300 Series
A22	Adjust Screw	Stainless Steel 300 Series
A23	Stop Screw	Stainless Steel 300 Series
A24	Nut (Stop Screw)	Stainless Steel 300 Series
A25	O-Ring (End Cap)	Buna "N" (standard)
A26	End Cap	Aluminum
A27	End Cap Screw	Stainless Steel 300 Series

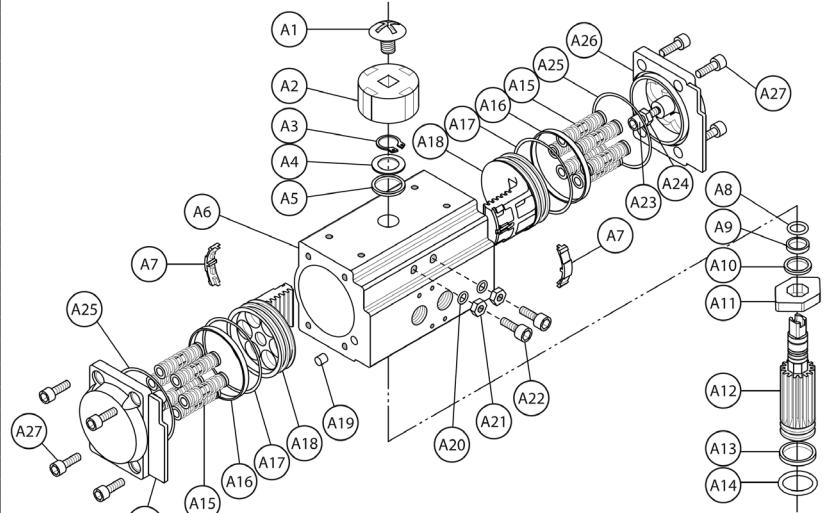

Actuator Weights

Actuator Size	Weight – lbs/kgs	
	Double Acting	Spring Return
35	4 2	4 2
50	6 3	6 3
75	7 3	7 3
110	10 5	12 5
160	13 6	14 6
255	19 9	22 10

Actuator Size	Weight – lbs/kgs	
	Double Acting	Spring Return
400	25 11	29 13
500	36 16	44 20
550	70 32	78 35
600	76 35	85 39
650	106 48	135 61
700	163 74	216 98

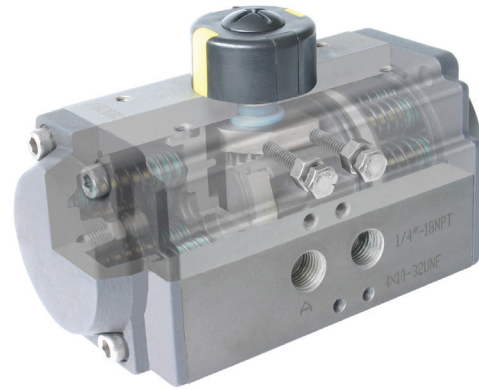

Weights are approximate and do not include crating.

Ordering

To order a Compak actuator, add the actuator order code from the appropriate sizing chart. Specify mounting position as second line information. An ordering example is shown for your reference.

Actuator Type

Give actuator style code as follows:

CMD = Double Acting or Spring Return Compak Cylinder Actuators

Actuator Size

Give actuator size code as follows:

35 = Size 035 400 = Size 400
 50 = Size 050 500 = Size 500
 75 = Size 075 550 = Size 550
 110 = Size 110 600 = Size 600
 160 = Size 160 650 = Size 650
 255 = Size 255 700 = Size 700

Spring Action

For Spring Return Actuators only.
 Leave field blank for double acting.
 Give spring action code as follows:

D = Direct, Spring to Open
 R = Reverse, Spring to Close

Actuator Mounting

Note: Specify also as 2nd line information on the order.

90 = 90 Degree clockwise from standard
 180 = 180 Degree clockwise from standard
 270 = 270 Degree clockwise from standard

Spring Quantity

For Spring Return Actuators only.
 Leave field blank for double acting.

Give spring quantity code as follows:

S7 = 7 Springs S10 = 10 Springs
 S8 = 8 Springs S11 = 11 Springs
 S9 = 9 Springs S12 = 12 Springs

Ordering Example:

BHP,3,W1,CS,TC,S2-S2-FT-TT*CMD-110-S7-R-180

Actuator mounted 180° from standard

Dimensions

BHP High Performance Butterfly Valves

Actuator Mounting

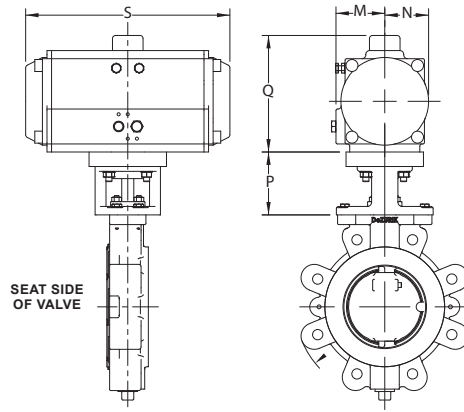
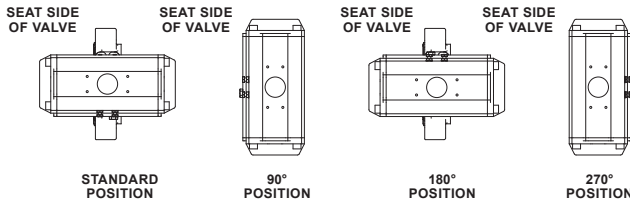

Double Acting

Actuator	M	N	Q	S
CMD-35	1.85	1.43	4.23	6.61
	47	36	107	168
CMD-50	2.08	1.65	4.70	7.24
	53	42	119	184
CMD-75	2.24	1.81	5.07	10.31
	57	46	129	262
CMD-110	2.30	1.97	5.38	10.31
	58	50	137	262
CMD-160	2.52	2.26	6.02	10.55
	64	57	153	268
CMD-255	2.93	2.66	6.89	11.65
	74	68	175	296
CMD-400	3.03	2.95	7.54	15.34
	77	75	192	390
CMD-500	3.43	3.43	8.54	18.03
	87	87	217	458
CMD-550	4.06	4.06	9.84	20.79
	103	103	250	528
CMD-600	4.45	4.45	11.22	22.20
	113	113	285	564

Actuator	Valve Size		P
	Class 150	Class 300	
CMD-35	2-3" 50-80mm	2-3" 50-80mm	3.00 76
	CMD-50	2-3" 50-80mm	2" 50mm
CMD-75		2.5-3" 65-80mm	2.5" 65mm
	CMD-110	4 & 5" 100-125mm	3 & 4" 80-100mm
CMD-160		3" 80mm	2.5" 65mm
	CMD-255	5" 125mm	3 & 4" 80-100mm
CMD-400		4-8" 100-200mm	5" 125mm
	CMD-500	6 & 8" 150 & 200mm	4" 100mm
CMD-550		6 & 8" 150 & 200mm	6 & 8" 150 & 200mm
	CMD-600	8" 200mm	6" 150mm
CMD-650		N/R	8" 200mm
	CMD-700	N/R	8" 200mm

Spring Return

Actuator	M	N	Q	S
CMD-50-S-__	2.08	1.65	4.70	7.24
	53	42	119	184
CMD-75-S-__	2.24	1.81	5.07	10.31
	57	46	129	262
CMD-110-S-__	2.30	1.97	5.38	10.31
	58	50	137	262
CMD-160-S-__	2.52	2.26	6.02	10.55
	64	57	153	268
CMD-255-S-__	2.93	2.66	6.89	11.65
	74	68	175	296
CMD-400-S-__	3.03	2.95	7.54	15.34
	77	75	192	390
CMD-500-S-__	3.43	3.43	8.54	18.03
	87	87	217	458
CMD-550-S-__	4.06	4.06	9.84	20.79
	103	103	250	528
CMD-600-S-__	4.45	4.45	11.22	22.20
	113	113	285	564
CMD-650-S-__	5.12	5.12	12.55	23.70
	130	130	319	602
CMD-700-S-__	5.79	5.79	14.01	27.80
	147	147	356	706

Actuator	Valve Size		P
	Class 150	Class 300	
CMD-50-S-__	2" 50mm	N/A	3.00 76
	CMD-75-S-__	2-3" 50-80mm	2 & 2.5" 50-65mm
CMD-110-S-__		N/R	3" 80mm
	CMD-160-S-__	2-3" 50-80mm	2 & 2.5" 50-65mm
CMD-255-S-__		N/R	3" 80mm
	CMD-400-S-__	2.5-3" 65-80mm	3" 80mm
CMD-500-S-__		4 & 5" 100-125mm	4" 100mm
	CMD-550-S-__	2.5-3" 65-80mm	2.5" 65mm
CMD-600-S-__		4 & 5" 100-125mm	3-5" 80-125mm
	CMD-650-S-__	N/R	2.5-3" 65-80mm
CMD-700-S-__		4-8" 100-200mm	4-6" 100-150mm
	CMD-750-S-__	6 & 8" 150 & 200mm	4-8" 100-200mm
CMD-800-S-__		6 & 8" 150 & 200mm	6 & 8" 150 & 200mm
	CMD-900-S-__	8" 200mm	6 & 8" 150 & 200mm
CMD-1000-S-__		N/R	6" 150mm
	CMD-1100-S-__	N/R	8" 200mm

Dimensions

PEC Eccentric Plug Valves

Actuator	L	M	N	Q	S
CMD-35	2.38 60	1.85 47	1.43 36	4.23 107	6.61 168
CMD-50	2.38 60	2.08 53	1.65 42	4.70 119	7.24 184
CMD-75	2.38 60	2.24 57	1.81 46	5.07 129	10.31 262
CMD-110	2.38 60	2.30 58	1.97 50	5.38 137	10.31 262
CMD-160	2.38 60	2.52 64	2.26 57	6.02 153	10.55 268
CMD-255	2.38 60	2.93 74	2.66 68	6.89 175	11.65 296
CMD-400	2.75 70	3.03 77	2.95 75	7.54 192	15.34 390
CMD-500	2.75 70	3.43 87	3.43 87	8.54 217	18.03 458

Inches
Millimeters

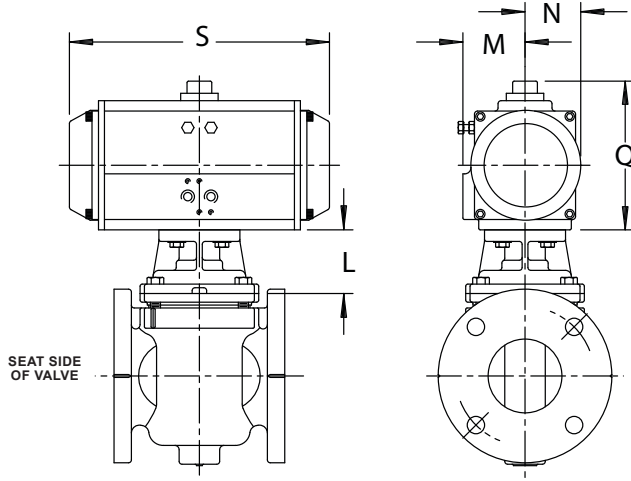

Actuator Mounting

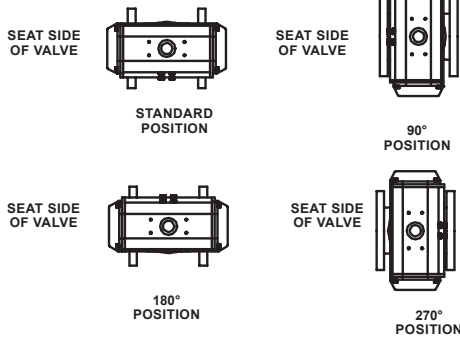

BOS-CL Butterfly Valves

Actuator	M	N	Q	S
CMD-35	1.85 47	1.42 36	4.73 120	6.61 168
CMD-50	2.09 53	1.65 42	5.20 132	7.24 184
CMD-75	2.24 57	1.81 46	5.57 141	10.31 262
CMD-160	2.52 64	2.26 57	6.52 166	10.55 268

Inches
Millimeters

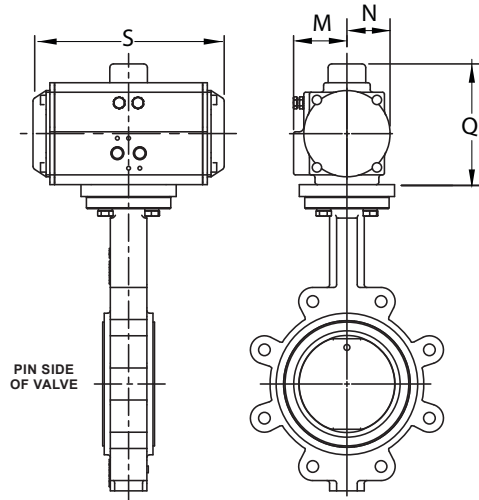

Actuator Mounting

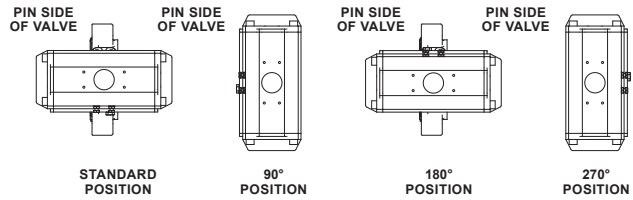

Sales and Service

For information about our worldwide locations, approvals, certifications and local representative:

Web Site: DeZURIK.com E-Mail: info@DeZURIK.com



250 Riverside Ave. N. Sartell, Minnesota 56377 • Phone: 320-259-2000 • Fax: 320-259-2227

DeZURIK, Inc. reserves the right to incorporate our latest design and material changes without notice or obligation. Design features, materials of construction and dimensional data, as described in this bulletin, are provided for your information only and should not be relied upon unless confirmed in writing by DeZURIK, Inc. Certified drawings are available upon request.