

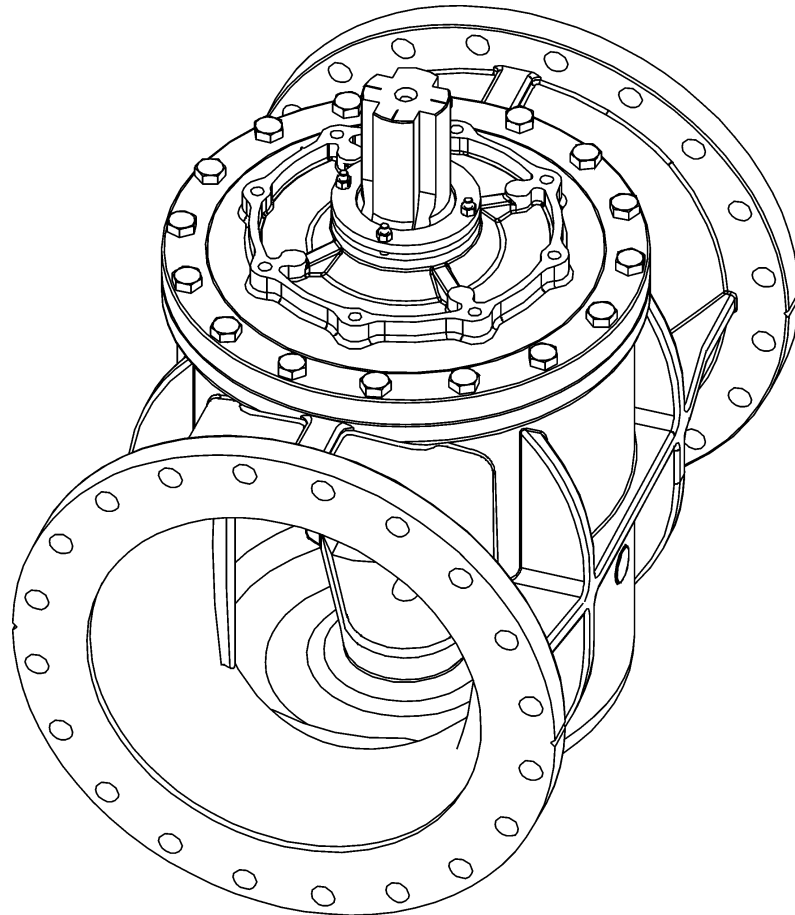

# DeZURIK 20.5-36" PEC ECCENTRIC VALVES



Instruction D10032  
June 2011

# DeZURIK

## 20.5 - 36" PEC Eccentric Valves

---

### Instructions

These instructions provide information about PEC Eccentric Valves. They are for use by personnel who are responsible for installation, operation and maintenance of PEC Eccentric Valves.

### Safety Messages

All safety messages in the instructions are flagged with an exclamation symbol and the word Caution, Warning or Danger. These messages indicate procedures that must be followed exactly to avoid equipment damage, personal injury or death. Safety label(s) on the product indicate hazards that can cause equipment damage, personal injury or death. If a safety label becomes difficult to see or read, or if a label has been removed, please contact DeZURIK for replacement label(s).



#### **WARNING!**

**Personnel involved in the installation or maintenance of valves should be constantly alert to potential emission of pipeline material and take appropriate safety precautions. Always wear suitable protection when dealing with hazardous pipeline materials. Handle valves, which have been removed from service with suitable protection for any potential pipeline material in the valve.**

---

### Inspection

Your PEC Eccentric Valve has been packaged to provide protection during shipment, however, it can be damaged in transport. Carefully inspect the unit for damage upon arrival and file a claim with the carrier if damage is apparent.

### Parts

Recommended spare parts are listed on the assembly drawing. These parts should be stocked to minimize downtime.

Order parts from your local DeZURIK sales representative, or directly from DeZURIK. When ordering parts, please include the 7-digit part number and 4-digit revision number (example: **9999999R000**) located on the data plate attached to the valve assembly. Also include the part name, the assembly drawing number, the balloon number and the quantity stated on the assembly drawing.

### DeZURIK Service

DeZURIK service personnel are available to install, maintain and repair all DeZURIK products. DeZURIK also offers customized training programs and consultation services.

For more information, contact your local DeZURIK sales representative or visit our website at [www.dezurik.com](http://www.dezurik.com).

## Table of Contents

Description - - - - -	4
Required Tools - - - - -	4
Installation - - - - -	4
Closed Position - - - - -	6
Lubrication	
<i>Packing</i> - - - - -	6
<i>Plug Journals and Lubrication</i> - - - - -	7
Packing Adjustment - - - - -	8
<i>Replacing Packing with Actuator Removed</i> - - - - -	8
<i>Replacing Packing Without Removing Actuator</i> - - - - -	9
Disassembly - - - - -	10
Reassembly - - - - -	11
Removing Valve from Pipeline - - - - -	12
Field Test - - - - -	12
Emergency Operation - - - - -	12
Predicted Wear of Parts - - - - -	12
Troubleshooting - - - - -	13

## Description

The 20.5 – 36" PEC Eccentric Valves have welded nickel seats that provide excellent resistance to corrosion and damage, and prolong the life of the resilient plug facing. The valve rotates 90 degrees from full open to full closed. Clockwise rotation of the valve stem closes the valve.

If an actuator other than a DeZURIK is to be mounted, the actuator must be capable of maintaining the valve plug position with flow in the pipeline.



### WARNING!

**This valve is a pressure vessel. Failure to release pipeline pressure may result in personal injury and/or flow system damage. Completely release pipeline pressure before removing the actuator from the valve or removing the valve from the pipeline.**

## Required Tools

This valve is assembled using only SAE fasteners. To service this valve, you should have a full set of combination wrenches, Allen wrenches, a large flat tipped screwdriver, a flat pry bar, a pin punch and a dead blow hammer.

## Installation

The type of materials carried in the pipeline and the location of the valve determine the correct installation procedure.

### Liquids and Gases

1. Before installation, remove foreign material such as weld spatter, oil, grease, and dirt from the valve and pipeline.
2. Install the valve as shown in Figure 1.

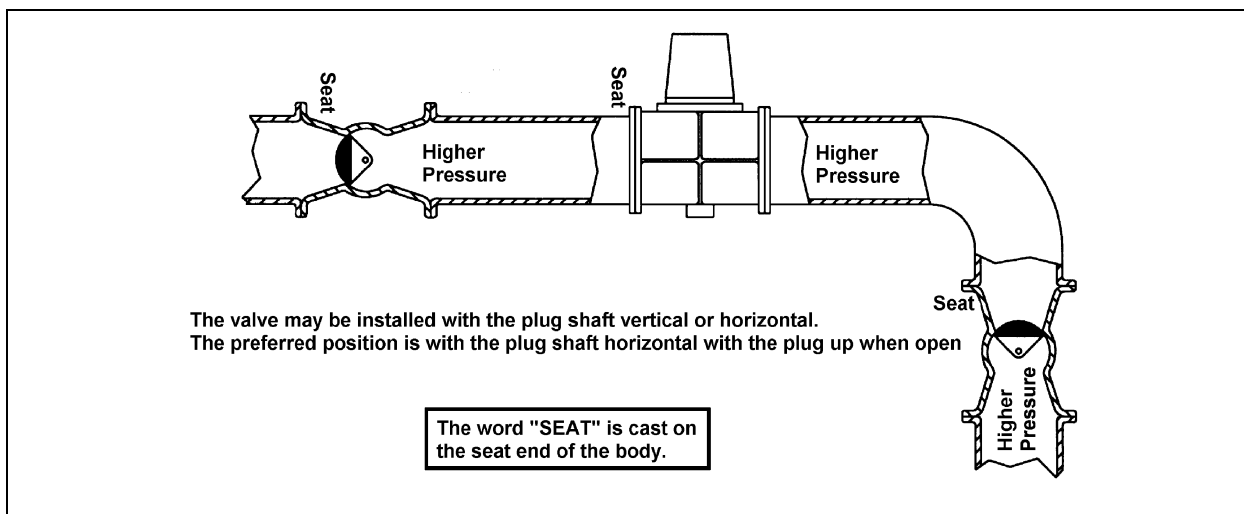

Figure 1—Liquids and Gases

3. Ensure the valve and flanges are concentric to ensure proper flange sealing.
4. Tighten the flange bolts or studs in a crisscross pattern.

**Installation (continued)****Suspended Solids**

If the pipeline carries suspended solids such as paper stock of 2 percent or higher consistency, mining slurry, or raw sewage:

1. Before installation, remove foreign material such as weld spatter, oil, grease, and dirt from the valve and pipeline.
2. Install the valve as shown in Figure 2.
  - a. In HORIZONTAL pipelines, install the valve so that the plug is horizontal and rotates upward as the valve opens.
  - b. For VERTICAL pipelines, install the valve with the end marked "SEAT" at top of valve.

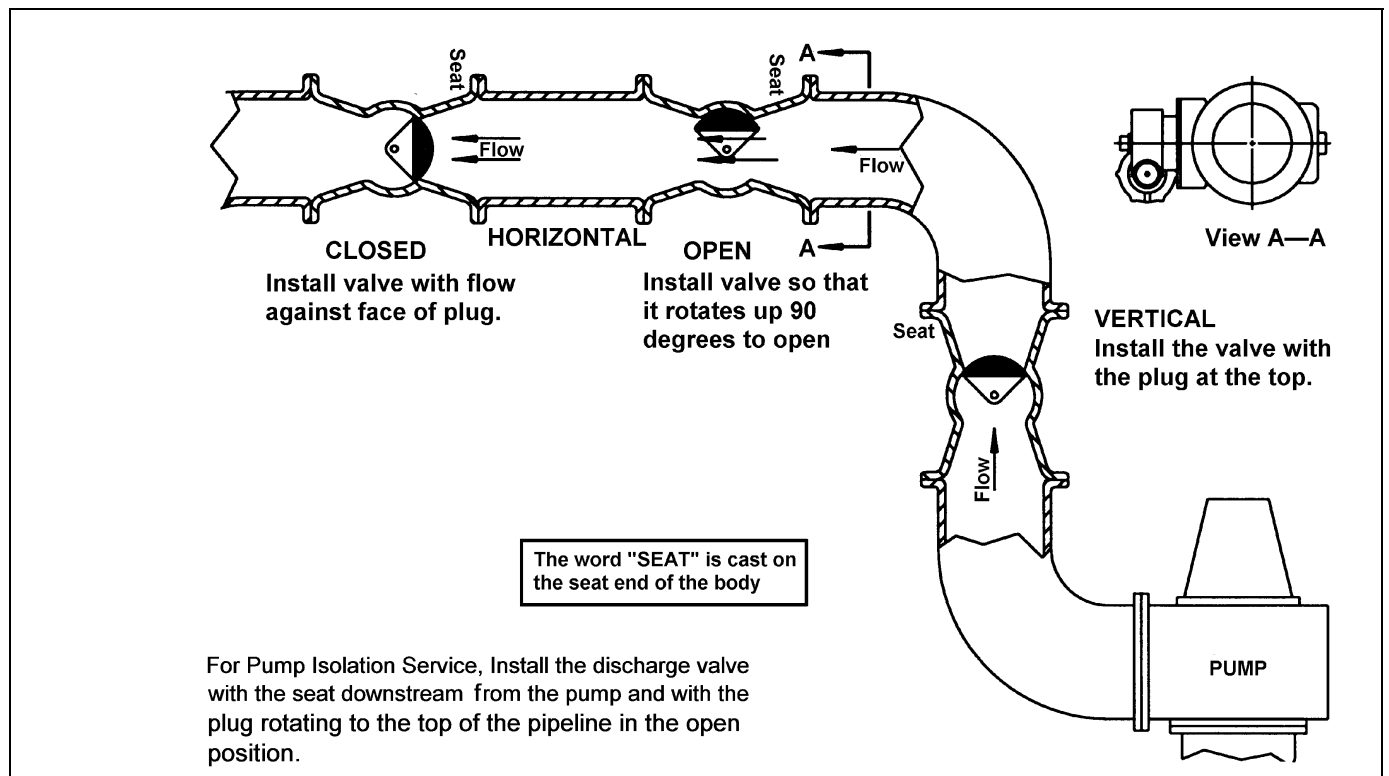

Figure 2—Liquids with Suspended Solids

3. Tighten the flange bolts or studs in a crisscross pattern.
4. Ensure the valve and flanges are concentric to ensure proper flange sealing.

### Closed Position

Because of the eccentric action of this valve, the closed position of the valve is dependent upon the pressure drop expected when the valve is closed.

To adjust the valve closed position, follow these steps:

1. Relieve pipeline pressure.



#### **WARNING!**

**Moving parts from accidental operation of power actuator can cause personal injury or equipment damage. Disconnect and lock out power to actuator before servicing.**

---

2. If the actuator is powered, disconnect and lock out the pneumatic, hydraulic, or electrical power to prevent accidental operation of the actuator.
3. Back off the actuator closed position stop as described in the Actuator Instructions.
4. Close the valve with the torque specified in the Actuator Instructions.  
*Note:* This torque is the amount required to seat the plug for a given pressure drop across the valve. To avoid excessive plug and seat wear caused by over torquing, use the actual pressure drop across the valve when determining correct closing torque.
5. After the valve has been closed using the correct amount of torque, set the actuator closed position stop to limit actuator travel at this position.

### Lubrication

This valve does not require routine maintenance lubrication. If the valve is disassembled, lubricate the packing and the plug journals as follows:

#### **Packing**

Packing lubrication requirements are dependent upon the packing material.

- **PTFE PACKING:**

Requires no lubrication.

- **ALL PACKING OTHER THAN PTFE:**

Apply a light coat to the inside and outside diameters of the packing rings using one of these lubricants.

- Keystone Nevastane HT1 (**recommended**)
- Amoco FG (alternate)
- Mobilgrease FM 101 (alternate)
- Petro-Canada Purity FG 2 (alternate)
- Phillips Philube PF (alternate)

*Note:* Ensure lubricant is compatible with flow media.

**Lubrication** *(continued)****Plug Journals and Lubrication***

Plug journal lubrication is dependent upon the materials used in construction of the valve.

- CAST IRON, DUCTILE IRON and NI-RESIST VALVES: Lubricate the journals on the plug using one of these lubricants.
  - Keystone Nevastane HT1 (**recommended**)
  - Amoco FG (alternate)
  - Mobilgrease FM 101 (alternate)
  - Petro-Canada Purity FG 2 (alternate)
  - Phillips Philube PF (alternate)
- ALL VALVES EXCEPT CAST IRON, DUCTILE IRON and NI-RESIST: Coat the journals on the plug with a light coat using one of these lubricants.
  - Dow Corning Molykote G Rapid paste (**recommended**)
  - Shell Retinax AM (alternate)
  - Shell Lithall MDS (alternate)

Then lubricate with a mixture of powdered graphite and one of these lubricants.

- Standard Oil #140 Gear Lube (**recommended**)
- Mobil Mobilgear 634 (alternate)
- Shell Omala 460 (alternate)
- Texaco Meropa 460 (alternate)
- Amoco MP (alternate)

### Packing Adjustment

To stop packing leakage, tighten the gland nuts uniformly until the leak stops.

**Note:** Do not continue tightening after leak stops. If the leak cannot be stopped by tightening the gland nuts, replace the packing.

### Packing Replacement

#### ***Replacing Packing with Actuator Removed***

To replace the packing without removing actuator, see “*Replacing Packing Without Removing Actuator*” section.

1. Discontinue pipeline flow and relieve pipeline pressure.
2. Scribe the actuator and valve bonnet for alignment when reassembling.



#### **WARNING!**

**Moving parts from accidental operation of power actuator can cause personal injury or equipment damage. Disconnect and lock out power to actuator before servicing.**

---

3. If the actuator is powered, disconnect and lock out the pneumatic, hydraulic, or electrical power to prevent accidental operation of the actuator.



#### **WARNING!**

**When an eccentric valve is mounted in a vertical pipeline— or mounted in a horizontal pipeline with the plug stem horizontal—gravity can cause the plug to swing to a lower position in the valve body when the actuator is removed. Place the plug in the lowest position before removing the actuator.**

---

4. Remove the actuator from the valve. See Actuator Instructions.
5. Remove the actuator adaptor (when used) from the valve.
6. Remove the packing gland nuts, then slide the packing gland off the valve shaft.
7. Pull the packing out of the bonnet.

## Packing Replacement *(continued)*

- Lubricate the new packing, then install it one ring at a time as shown in Figure 3.

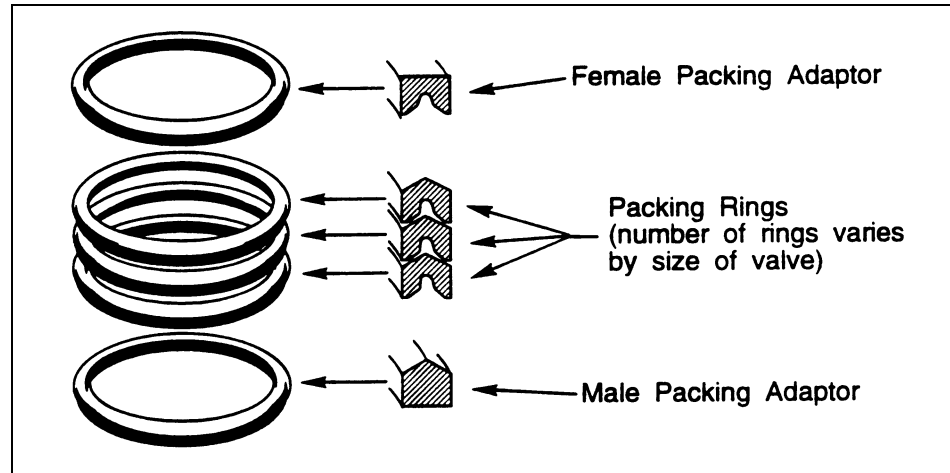

Figure 3—Correct Packing Installation Sequence

- Slide the packing gland down the valve shaft and over the studs.
- Turn the packing gland nuts onto the studs finger tight plus  $\frac{1}{2}$  turn.

**Note:** This is a preliminary adjustment, it will be necessary to adjust the packing gland nuts after the valve is pressurized. See "*Packing Adjustment*" section.

- Install the actuator as described in the Actuator Instructions.
- If the actuator is a powered actuator, reconnect power to the actuator.

## Replacing Packing Without Removing Actuator



### WARNING!

Excessive pipeline pressure can propel the loose packing, and can cause personal injury or equipment damage. If possible, relieve the pressure in the pipeline to 0 psi before removing the packing gland.

- Ensure that the pipeline pressure does not exceed 25 psi—if possible, relieve the pressure to 0 psi.



### WARNING!

Caustic, toxic, or hot material in the pipeline can cause personal injury or death if leakage occurs. Confirm that the material is not harmful.

- Ensure that the material in the pipeline will not cause injury if leakage occurs.

### Packing Replacement *(continued)*

3. Remove the packing gland nuts from the studs, and slide the packing gland up the stem of the plug.
4. Remove the studs from the bonnet.
5. Cut and completely remove all of the old packing from the packing chamber in the bonnet.
6. Cut each new packing ring radially in one place with a razor-sharp knife.
7. Place each new packing ring—one at a time with the joints staggered—around the plug and into position in the packing chamber.
8. Replace the studs in the bonnet.
9. Push the rings down into position with the packing gland, and replace the packing gland nuts on the studs.
10. Turn the packing gland nuts onto the studs until they touch the packing gland, then one more turn.
11. Restore the pipeline pressure, and check for packing leakage. If leakage occurs, tighten each packing nut just enough to stop the leakage. Excessive tightening will cause reduced packing life and higher valve operating torque.

### Disassembly



#### **WARNING!**

**This valve is a pressure vessel. The bonnet will blow off the body if the bonnet bolts are removed with pressure in the valve. Pressure must be completely released before disassembly.**

---

Follow these steps to disassemble valve:

1. Relieve pipeline pressure and close the valve.



#### **WARNING!**

**Moving parts from accidental operation of power actuator can cause personal injury or equipment damage. Disconnect and lock out power to actuator before servicing.**

---

2. If the actuator is powered, disconnect and lock out the pneumatic, hydraulic, or electrical power to prevent accidental operation of the actuator.
3. If desired, remove the valve from the pipeline.

**Note:** The valve can be disassembled while still in the pipeline.

## Disassembly *(continued)*



### **WARNING!**

**When an eccentric valve is mounted in a vertical pipeline— or mounted in a horizontal pipeline with the plug stem horizontal—gravity can cause the plug to swing to a lower position in the valve body when the actuator is removed. Place the plug in the lowest position before removing the actuator.**

---

4. Remove actuator from valve—see Actuator Instructions.
5. Scribe a line on the body, bonnet and plug stem to help align these parts during re-assembly.
6. Remove the bolts that hold the bonnet in place, then pry the bonnet loose from the valve body.
7. Remove the plug.
8. Remove the gland nuts and gland from the bonnet.
9. Remove the packing from the bonnet.
10. Reaching through the packing chamber in the bonnet, drive the upper bearing out of the bonnet using a hammer and pin punch.
11. Remove the lower journal cover from the body and drive the lower bearing out using a hammer and a punch pin.

## Reassembly

1. Push a new lower bearing into the valve body, then lubricate the bearing. See "Lubrication" section.
2. Replace the journal cover on lower bearings and tighten screws.
3. Place the plug into the valve body so the lower journal slides into the bushing.
4. Turn the plug so it is nearly closed.
5. Set a new gasket in the body.
6. Push a new bearing into the bonnet, then lubricate the bearing. See "Lubrication" section.
7. Align the scribe marks in the bonnet and plug stem, then install and tighten the bonnet bolts.
8. Place the plug to the closed position. See "Closed Position" section.
9. Install the packing one ring at a time. See Figure 3.
10. Install the packing gland and nuts.
11. Tighten the gland nuts finger tight plus ½ turn.

**Note:** This is a preliminary adjustment, it will be necessary to adjust the packing gland nuts after the valve is pressurized. See "Packing Adjustment" section.

12. Install the actuator—see Actuator Instructions.
13. After pipeline flow is restored, check the packing for leakage.

**Note:** If packing leaks, tighten the packing gland nuts only enough to stop the leak. Over tightening the packing will cause premature packing failure and higher valve operating torque.

14. If the actuator is a powered actuator, reconnect power to the actuator.

### Removing Valve from Pipeline

To remove the entire valve assembly from the pipeline, follow these steps.



#### **WARNING!**

**This valve is a pressure vessel. Failure to release pipeline pressure may result in personal injury and/or flow system damage. Completely release pipeline pressure before removing the actuator from the valve or removing the valve from the pipeline.**

---

1. Relieve pipeline pressure and drain portion of system where valve is located.
2. Close the valve.



#### **WARNING!**

**Moving parts from accidental operation of power actuator can cause personal injury or equipment damage. Disconnect and lock out power to actuator before servicing.**

---

3. If the actuator is powered, disconnect and lock out the pneumatic, hydraulic, or electrical power to prevent accidental operation of the actuator.
4. Support the valve assembly, then remove the flange bolts.
5. Remove the valve from the pipeline.

### Field Test

Stroke the valve between the fully open and fully closed positions to verify that the valve and actuator are functioning properly.

### Emergency Operation

Operate the valve as under normal conditions, taking care to bring the plug to the position required by the particular emergency condition.

### Predicted Wear of Parts

Length of service for parts subject to wear is dependent on service conditions.

## Troubleshooting

Symptom	Possible Cause	Corrective Action
Packing Leaks.	Packing is loose.	Adjust Packing. (See <i>Packing Adjustment</i> section)
	Packing is worn.	Replace Packing. (See <i>Packing Replacement</i> section)
Valve does not close.	Object is wedged between plug and seat.	Completely open the valve to flush object from the valve. If flushing does not work, remove valve from the pipeline and remove object. (See <i>Removing Valve from Pipeline</i> section)
	Actuator closed position is out of adjustment.	Adjust the closed position stop. See Actuator Instructions.
Valve leaks when closed.	Plug is worn or damaged.	Replace plug. See <i>Disassembly</i> and <i>Reassembly</i> sections.
	Rubber on plug is torn.	

## Guarantee

Products, auxiliaries and parts thereof of DeZURIK, Inc. manufacture are warranted to the original purchaser for a period of twenty-four (24) months from date of shipment from factory, against defective workmanship and material, but only if properly installed, operated and serviced in accordance with DeZURIK, Inc. recommendations. Repair or replacement, at our option, for items of DeZURIK, Inc. manufacture will be made free of charge, (FOB) our facility with removal, transportation and installation at your cost, if proved to be defective within such time, and this is your sole remedy with respect to such products. Equipment or parts manufactured by others but furnished by DeZURIK, Inc. will be repaired or replaced, but only to the extent provided in and honored by the original manufacturers warranty to DeZURIK, Inc., in each case subject to the limitations contained therein. No claim for transportation, labor or special or consequential damages or any other loss, cost or damage shall be allowed. You shall be solely responsible for determining suitability for use and in no event shall DeZURIK, Inc. be liable in this respect. DeZURIK, Inc. does not guarantee resistance to corrosion, erosion, abrasion or other sources of failure, nor does DeZURIK, Inc. guarantee a minimum length of service. Your failure to give written notice to us of any alleged defect under this warranty within twenty (20) days of its discovery, or attempts by someone other than DeZURIK, Inc. or its authorized representatives to remedy the alleged defects therein, or failure to return product or parts for repair or replacement as herein provided, or failure to install and operate said products and parts according to instructions furnished by DeZURIK, Inc., or misuse, modification, abuse or alteration of such product, accident, fire, flood or other Act of God, or failure to pay entire contract price when due shall be a waiver by you of all rights under this warranty.

The foregoing guarantee shall be null and void if, after shipment from our factory, the item is modified in any way or a component of another manufacturer, such as but not limited to, an actuator is attached to the item by anyone other than DeZURIK, Inc. Factory Service personnel. All orders accepted shall be deemed accepted subject to this limited warranty, which shall be exclusive of any other or previous Warranty, and this shall be the only effective guarantee or warranty binding on DeZURIK, Inc., despite anything to the contrary contained in the purchase order or represented by any agent or employee of DeZURIK, Inc., in writing or otherwise, notwithstanding, including but not limited to implied warranties.

THE FOREGOING REPAIR AND REPLACEMENT OBLIGATIONS ARE IN LIEU OF ALL OTHER WARRANTIES, OBLIGATIONS AND LIABILITIES, INCLUDING ALL WARRANTIES OF FITNESS FOR A PARTICULAR PURPOSE OR OF MERCHANTABILITY OR OTHERWISE, EXPRESSED OR IMPLIED IN FACT OR BY LAW, AND STATE DEZURIK, INC.'S ENTIRE AND EXCLUSIVE LIABILITY AND YOUR EXCLUSIVE REMEDY FOR ANY CLAIM IN CONNECTION WITH THE SALE AND FURNISHING OF SERVICES, GOODS OR PARTS, THEIR DESIGN, SUITABILITY FOR USE, INSTALLATION OR OPERATIONS.

## Limitation of liability

LIMITATION OF LIABILITY: IN NO EVENT SHALL DEZURIK, INC. BE LIABLE FOR ANY DIRECT, INDIRECT, SPECIAL OR CONSEQUENTIAL DAMAGES WHATSOEVER, AND DEZURIK, INC.'S LIABILITY, UNDER NO CIRCUMSTANCES, WILL EXCEED THE CONTRACT PRICE FOR THE GOODS AND/OR SERVICES FOR WHICH LIABILITY IS CLAIMED. ANY ACTION BY YOU FOR BREACH OF CONTRACT MUST BE COMMENCED WITHIN 12 MONTHS AFTER THE DATE OF SALE.

## Sales and Service

For information about our worldwide locations, approvals, certifications and local representative:

Web site: [www.dezurik.com](http://www.dezurik.com) E-Mail: [info@dezurik.com](mailto:info@dezurik.com)



250 Riverside Ave. N., Sartell, MN 56377 • Phone: 320-259-2000 • Fax: 320-259-2227

*DeZURIK, Inc. reserves the right to incorporate our latest design and material changes without notice or obligation. Design features, materials of construction and dimensional data, as described in this manual, are provided for your information only and should not be relied upon unless confirmed in writing by DeZURIK, Inc. Certified drawings are available upon request.*