

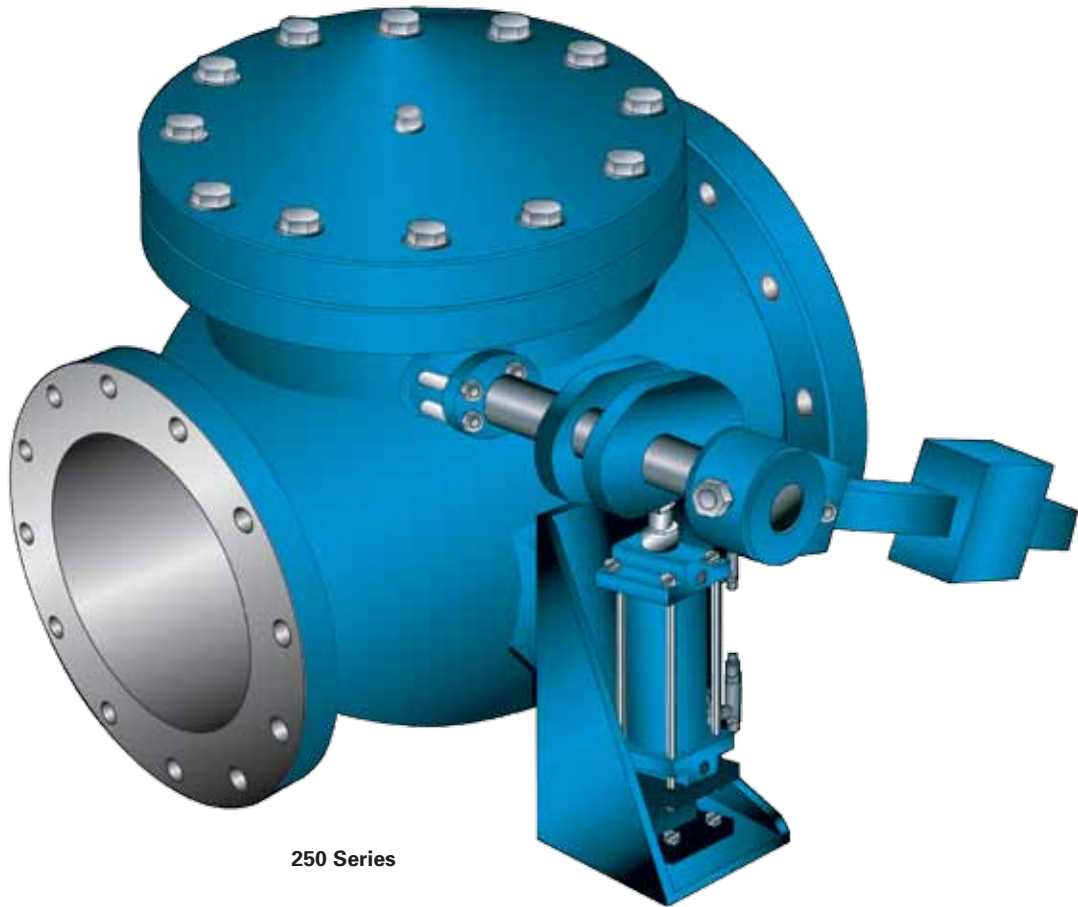

APCO SWING CHECK VALVE WITH AIR CUSHIONED CYLINDER



250 Series

Series 250 Swing Check Valve with Air Cushion Cylinder

About Check Valves

There are (4) four basic types of Check Valves, three of which are listed in several forms:

I. Swing Check Valve

- a. Single Disc
(conventional type)
- b. Slanting Disc
- c. Multi Disc

II. Lift Check Valve

- a. Poppet
- b. Disc
- c. Ball

III. Foot Check Valve

- a. Swing — single
and multi disc
- b. Lift — single
poppet or ball

IV. Flap Check Valve

- a. Single flap

All these valves perform one single common function, flow thru in one direction, but non return.

The important advantage of the Conventional Swing Check Valve is full unobstructed flow area and low head loss, especially desirable in sewage installations. This is accomplished by locating the disc pivot point well outside the periphery of the disc, thus enabling the entire disc to lift clear of the flow.

However, in many installations this is not an advantage because the disc is un-balanced and upon closing, (after pump stops) reverse flow will cause the disc to slam closed.

To minimize slamming, the APCO 250 Swing Check Valves are designed with an outside lever and weight and Air Cushion Cylinder. Under normal conditions the lever and weight causes the disc to close upon pump shutdown before reverse flow takes place, utilizing an external Air Cushion Cylinder (described in detail below).

How It Works

1. The discharge velocity head from the pump against disc (No. 05) opens the disc and raises the weighted lever (No. 12) on the outside of the valve. At the same time the piston inside the cushion cylinder (No. 9) is pulled upwards and draws air into the cushion cylinder through the small "one way" check valve.
2. When reverse flow occurs against backside of disc (No. 5) the pressure forces the disc into the shutoff position against the seat, while at the same time the piston inside the cushion cylinder is forced downwards. In so doing, the piston traps air in the cushion cylinder compressing the trapped air, creating the cushion during valve closure. The only remaining escape route for the air from the cushion cylinder is through the cylinder control valve. The air cushion is created by restricting the air escape through the adjustable control valve.
3. The cushioning starts when the valve disc is approximately 95% closed. Therefore, the disc closes freely thru 95% of its stroke and air is cushioned the remaining 5% of stroke to shut off. The cushioning is field adjustable.

How To Install

The APCO 250 Swing Check Valve with Air Cushion Cylinder may be installed horizontally or vertically on the discharge side of the pump.

The counter weight arm is recommended to be equipped with one weight (No. 12) for typical installations. The weight will hold the disc (No. 05) against the seat to keep the valve closed and can be removed if not required.

Note: Some installations may require extra weight.

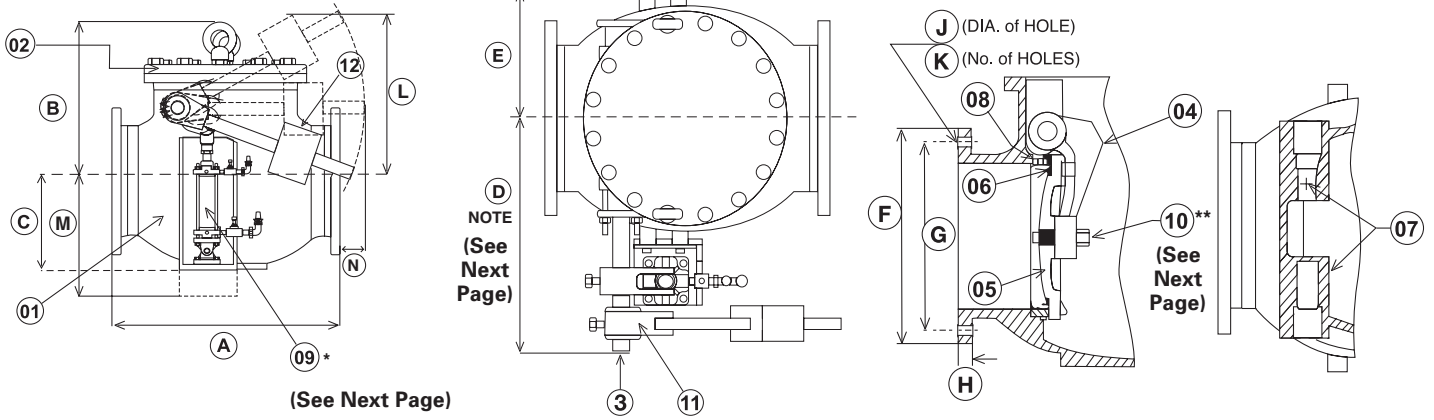

(See Next Page)

NOTE
(See Next Page)

(See Next Page)

- A - Face to Face
- B - Center to Top
- C - Center to Body Base
- D - Center to Slide CWT End
- E - Center to Body Side
- F - Flange Diameter
- G - Bolt Circle Diameter
- H - Flange Thickness
- J - Bolt Holes Diameter
- K - Number of Bolt Holes
- L - Center to Top CWT Swing
- M - Center to Cylinder Base
- N - Flange Face to CWT Swing

APCO 250 Swing Check Valves with Air Cushion Cylinders Operate Equally as Well in the Vertical Position.

Note: APCO 250 Swing Check Valves With Air Cushion Cylinder are Recommended For Use on Raw Sewage or Water Pumping Stations

Overall Dimensions for 125#/150# Class Valves															
Model	Size	A	B	C	D	E	F	G	H	J	K	L	M	N	Weight (Approx. lbs/kg)
250-3	3" 80	12 305	10 254	4.5 114	11 279	4 102	7.5 191	6 152	.75 19	.75 19	4	7.5 191	12 305	4.5 114	110 50
250-4	4" 100	13 330	10.75 273	5 127	11.75 298	5 127	9 229	7.5 191	.938 24	.75 19	8	10.25 260	11.5 292	4.75 121	145 66
250-6	6" 150	17.5 445	11.75 298	5.75 146	13.5 343	6.5 165	11 279	9.5 241	1 25	.875 22	8	12.5 318	10.5 267	2.25 57	205 93
250-8	8" 200	18 457	13.75 349	7.25 184	17 432	7.5 191	13.5 343	11.75 298	1.125 29	.875 22	8	16 406	14.25 362	1.75 44	330 150
250-10	10" 250	23 584	15 381	9.375 238	16.25 413	9 229	16 406	14.25 362	1.188 30	1 25	12	16.75 425	13.5 343	0	500 227
250-12	12" 300	28 711	19 483	11 279	18.25 464	11 279	19 483	17 432	1.25 32	1 25	12	20.25 514	13.25 337	4 102	800 363
250-14	14" 350	33 838	22.5 572	13.5 343	26 660	14 356	21 533	18.75 476	1.375 35	1.125 29	12	29 737	13.25 337	3 76	1260 572
250-16	16" 400	36 914	24.5 622	14.25 362	29.5 749	15 381	23.5 597	21.25 540	1.438 37	1.125 29	16	32 813	14.5 368	2 51	1600 726
250-18	18" 450	40 1016	26.5 673	17.375 441	31 787	18.625 473	25 635	22.75 578	1.563 40	1.25 32	16	36 914	13 330	7 178	2100 953
250-20	20" 500	40 1016	28.75 730	17.625 448	32.375 822	18.625 473	27.5 699	25 635	1.688 43	1.25 32	20	41 1041	14.5 368	6 152	2500 1134
250-24	24" 600	48 1219	32.5 826	20.125 511	34 864	21 533	32 813	29.5 749	1.875 48	1.375 35	20	38 965	11.75 298	0	3700 1678
250-30	30" 750	56 1422	44.125 1121	29.75 756	39 991	24 610	38.75 984	36 914	2.125 54	1.375 35	28	53.125 1349	17.25 438	14.125 359	6000 2722
250-36	36" 900	63 1600	50.5 1283	33.5 851	42 1067	27 686	46 1168	42.75 1086	2.375 60	1.625 41	32	57.5 1461	13 330	14.625 371	9100 4128

Inch
Millimeter

Features

- Ductile iron construction standard
- Stainless Steel trim and cover bolts standard
- Fusion bond epoxy lined and coated standard
- Replaceable non-corrosive stainless steel seat
- All internal parts replaceable without removing valve from the line

Adjustments

The external air cushion cylinder is adjustable as follows:

- Increased cushioning — screw in (clock-wise) the cylinder control valve
- Decreased cushioning — screw out (counter clockwise) the cylinder control valve
- More rapid disc closing — move weight towards outer end of lever
- Less rapid disc closing — move weight towards pivot shaft

Specifications

Swing Check Valve with Air Cushion Cylinder shall be constructed of heavy ductile iron body with a stainless steel body seat ring and single continuous stainless steel shaft for attachment of outside weight and lever and a totally enclosed air cushion cylinder.

The valve shall prevent the return of water or sewage back through the valve on pump shut off or power failure and be tight seating. The seat ring must be renewable and securely held in place by stainless steel screws.

The cushion cylinder assembly shall be externally attached to the side of the valve body. The cylinder piston rod is connected to the external lever arm in a manner to lift the piston upwards when flow starts and downwards when the flow stops to compress the entrapped air in the cylinder for cushion closing. The cushion cylinder shall be fitted with an adjustable control valve to increase or decrease air compression in the cylinder.

The valve disc shall be ductile iron suspended from a stainless steel shaft which shall pass through a stuffing box and be connected to the cushion cylinder on the outside of the valve.

This valve shall be guaranteed for a period of one year against failure to operate due to faulty workmanship or defective material. The valve shall be APCO Series 250 Swing Check Valve with Air Cushion cylinder with ANSI 125/150# class flanges (rated for 250 PSI, flat faced standard).

Valve meets or exceeds AWWA C-508.

*This valve comes standard fusion bond epoxy lined (12 mils minimum) and coated (8 mils minimum). Stainless steel trim and cover bolts are standard.

Standard Materials		
DET	Description	Material
1	Body	Ductile Iron ASTM A536 GR. 65-45-12
2	Cover	Ductile Iron ASTM A536 GR. 65-45-12
3	Pivot Shaft	Stainless Steel T303
4	Disc Arm	Ductile Iron ASTM A536 GR. 65-45-12
5	Disc	Ductile Iron ASTM A536 GR. 65-45-12
6	Disc Seat	Buna-N
7	Pivot Shaft Bushing	Stainless Steel T304
8	Body Seat Ring	Stainless Steel T304
9	Air Cylinder*	Aluminum Alloy
10	Disc Nut**	Stainless Steel T304
11	Counter Weight Arm	Ductile Iron ASTM A536 GR. 65-45-12
12	Counter Weight	Ductile Iron ASTM A536 GR. 65-45-12
Note: 36" valve has counter weight assembly on BOTH SIDES of valve. * 36" has double air cylinders. ** 30" and 36" have a double clevis disc connection		

Sales and Service

For information about our worldwide locations, approvals, certifications and local representative:

Web Site: www.dezurik.com E-Mail: info@dezurik.com



250 Riverside Ave. N. Sartell, Minnesota 56377 • Phone: 320-259-2000 • Fax: 320-259-2227

DeZURIK, Inc. reserves the right to incorporate our latest design and material changes without notice or obligation. Design features, materials of construction and dimensional data, as described in this bulletin, are provided for your information only and should not be relied upon unless confirmed in writing by DeZURIK, Inc. Certified drawings are available upon request.