

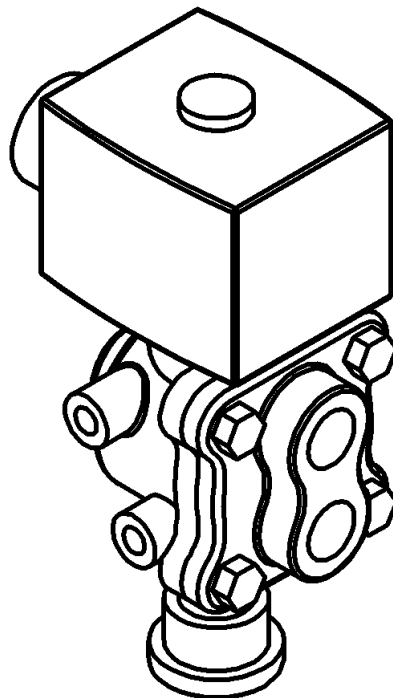

APCO | WILLAMETTE

ASCO 4V 4-WAY PILOT VALVE

USED WITH DeZURIK DIAPHRAGM
AND CYLINDER ACTUATORS



DeZURIK

ASCO 4V 4-Way Pilot Valve used with Diaphragm and Cylinder Actuators

Instructions

These instructions provide information about ASCO 4V 4-way pilot valves. They are for use by personnel who are responsible for installation, operation and maintenance of ASCO 4V 4-way pilot valves.

Safety Messages

All safety messages in the instructions are flagged with an exclamation symbol and the word Caution, Warning or Danger. These messages indicate procedures that must be followed exactly to avoid equipment damage, personal injury or death. Safety label(s) on the product indicate hazards that can cause equipment damage, personal injury or death. If a safety label becomes difficult to see or read, or if a label has been removed, please contact DeZURIK for replacement label(s).



WARNING!

Personnel involved in the installation or maintenance of valves should be constantly alert to potential emission of pipeline material and take appropriate safety precautions. Always wear suitable protection when dealing with hazardous pipeline materials. Handle valves that have been removed from service with the assumption of pipeline material within the valve.

Inspection

Your pilot valve has been packaged to provide protection during shipment; however, it can be damaged in transport. Carefully inspect the unit for damage upon arrival and file a claim with the carrier if damage is apparent.

Parts

Order parts from your local DeZURIK sales representative, or directly from DeZURIK. When ordering parts, please include the 7-digit part number and 4-digit revision number (example: **9999999R000**) located on the data plate attached to the valve assembly. Also include the part name, the assembly drawing number, the balloon number and the quantity stated on the assembly drawing.

DeZURIK Service

DeZURIK service personnel are available to install, maintain and repair all DeZURIK products. DeZURIK also offers customized training programs and consultation services.

For more information, contact your local DeZURIK sales representative or visit our website at www.dezurik.com.

Table of Contents

Description - - - - -	4
Operation	
<i>Double-Acting Actuators</i> - - - - -	4
<i>Single-Acting Actuators</i> - - - - -	4
Electrical Characteristics - - - - -	4
Installation	
<i>Mounting on Diaphragm Actuators</i> - - - - -	5
<i>Mounting on Double Acting and Spring Return Gear Unit Actuators</i> - - - - -	5
<i>Mounting on Compact Pneumatic Actuators</i> - - - - -	6
<i>Piping and Electrical Connections</i> - - - - -	6
Reversing the Action - - - - -	7
Operating The Manual Override (8342 Series) - - - - -	7
Operating The Optional Manual Override (8344 Series) - - - - -	7
Speed Controls - - - - -	8

DeZURIK

ASCO 4V 4-Way Pilot Valve used with Diaphragm and Cylinder Actuators

Description

The ASCO 4V 4-way solenoid pilot valve is used on cylinder and diaphragm actuators to provide electrical control of the valve operation. Refer to the data plate attached to the solenoid pilot valve for specific product limitations. Manual override and integral speed controls are also available for the 8342 series pilot valve. Manual override is available on 8344 series pilot valves.

Operation

Double-Acting Actuators

When the solenoid is energized on a double acting actuator, it will route the supply air to one of the cylinder ports; when the solenoid is de-energized, it will route the supply air to the other cylinder port.

Note: Ports are marked "A" and "B" —reversing the connections will cause reverse operation.

Single-Acting Actuators

When the ASCO 4V 4-way solenoid pilot valve is used on a single acting actuator, one of the ports must be plugged.

Note: Ports are marked "A" and "B" —reversing the connections will cause reverse operation.

Electrical Characteristics

This pilot valve is available in several different voltages. Refer to the data plate on the pilot valve for the electrical characteristics of that unit.



CAUTION!

Applying the wrong voltage/hertz can cause the solenoid coil to overheat and malfunction. Verify that the supply voltage/hertz matches the rating on the pilot valve before applying power.



CAUTION!

If pilot valve is supplied with dual coils, do not energize both solenoids simultaneously.

Installation

Mounting on Diaphragm Actuators

The solenoid valve is bracket-mounted and attached to one of the cover screws.

1. Refer to the assembly drawing.
2. Mount the bracket to the solenoid valve with the included screws.
3. Remove one of the diaphragm cover mounting screws.
4. Mount the bracket in the same hole with the longer screw (included with kit), and the same washer and nut. Installation
5. Tighten the screw as shown in Table A.

Table A: Diaphragm Cover Torques

Model	Torque, ft. lbs
40	6±2
55	12±2
85	18±2
145	12±2
250	18±2

6. Proceed to “Piping and Electrical Connections” section.

Mounting on Double Acting and Spring Return Gear Unit Actuators

1. Refer to the assembly drawing.
2. Mount the bracket to the solenoid valve with the included screws.
3. Remove one of the cylinder tie rod nuts.
4. Mount the bracket in the same hole with the same nut and washer.
5. Tighten the nut to the torque shown in Table B.

Table B: Tie Rod Nut Torques

Fastener	Size	Torque, ft. lbs
Tie Rod Nuts	5/16-18	12 ± 2
	1/2-13	16 ± 2
	5/8-11	20 ± 2
	7/8-9	35 ± 5

6. Proceed to “Piping and Electrical Connections” section.

DeZURIK

ASCO 4V 4-Way Pilot Valve used with Diaphragm and Cylinder Actuators

Installation (Continued)

Mounting on Compact Pneumatic Actuators

1. Refer to the assembly drawing.
2. Mount the bracket to the solenoid valve with the included screws.
3. Mount the bracket to the top of the actuator as shown in the assembly drawing.
4. Proceed to “Piping and Electrical Connections” section.

Piping and Electrical Connections

1. Install the piping following the appropriate procedure:
 - Hose
 - a. Refer to the assembly drawing for piping requirements.
 - b. Make threaded connections first, and use liquid or paste thread sealant—do not use Teflon[®] tape.
 - c. Cut hose to length and install a swivel connector on one end of each hose.
Note: To prevent kinks in hose, allow for at least 2" bend radii.
 - d. Push ends of hose firmly on the barbed connections.
Note: Ports are marked “A” and “B”—reversing the connections will cause reverse operation.
 - Pipe/Tubing
 - a. Refer to the assembly drawing for piping requirements.
 - b. Make the threaded connections and seal with a liquid or paste thread sealant—do not use Teflon[®] tape.
 - c. Cut and bend pipe as shown in the installation drawing.
 - d. Connect the pipe with flared fittings.
Note: Ports are marked “A” and “B”—reversing the connections will cause reverse operation.



CAUTION!

Applying the wrong voltage/hertz can cause the solenoid coil to overheat and malfunction. Verify that the supply voltage/hertz matches the rating on the pilot valve before applying power. If pilot valve is supplied with dual coils, do not energize both solenoids simultaneously.

2. Check the electric rating on data plate and connect the proper power to solenoid.
-



CAUTION!

If pilot valve is supplied with dual coils, do not energize both solenoids simultaneously.

Reversing the Action

The valve assembly may be piped to open or to close the valve when the solenoid is energized. To reverse the action, follow these steps:

1. Close the valve.
2. If the actuator is powered, disconnect and lock out the pneumatic, hydraulic, or electrical power to prevent accidental operation of the actuator.



WARNING!

Moving parts from accidental operation of power actuator can cause personal injury or equipment damage. Disconnect and lock out power to the actuator before servicing.

3. Relieve the pressure from the actuator port(s).
4. Reverse the actuator piping at the pilot valve.
5. If the actuator is a powered actuator, reconnect power to the actuator.

Operating The Manual Override (8342 Series)

The optional manual override can be used to operate the valve when electrical power is not available.

To operate the manual override, follow these steps:

1. Pull the red knob out, turn it 30 degrees in either direction and release it.
Note: It will not go in as far as it was initially. This will provide the same action as energizing the solenoid.
2. To return the manual override to electrical control, pull out the red knob, turn it 30 degrees in either direction and release it.

Operating The Optional Manual Override (8344 Series)

The optional manual override can be used to operate the valve when electrical power is not available.

To operate the manual override, follow these steps:

1. Rotate stem just below solenoid enclosure clockwise.
Note: This will provide the same action as energizing the solenoid.
2. To return the manual override to electrical control, rotate stem counter clockwise.

DeZURIK

ASCO 4V 4-Way Pilot Valve used with Diaphragm and Cylinder Actuators

Speed Controls

When the pilot valve is equipped with the optional speed controls, they are positioned as shown in Figure 1. The speed controls are set at the factory to provide slow actuator operation. Turning the speed controls clockwise will increase the speed of actuator operation. When changing the speed of operation, adjust the speed controls slightly, then check the new speed of operation. Repeat the procedure until the desired speed is obtained.

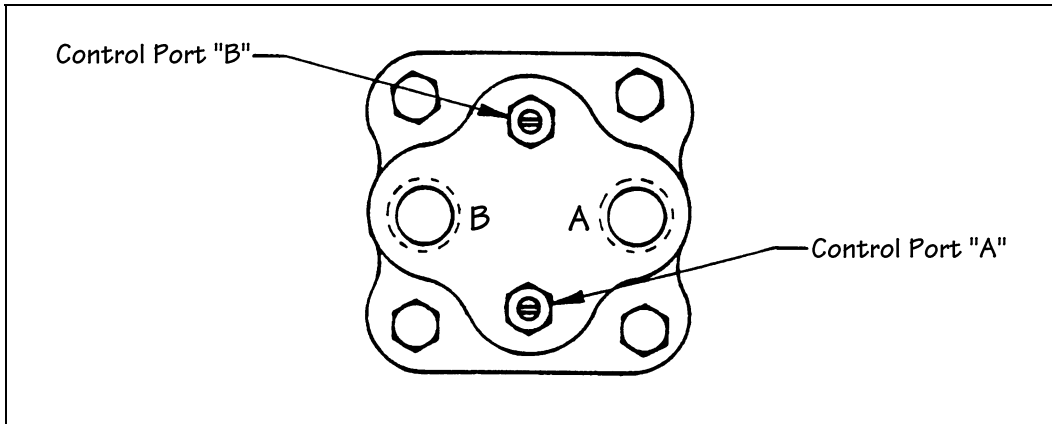

Figure 1 – Speed Control Ports