



APCO AIR RELEASE VALVES



Series 140
.5" (15 mm) - 3" (80 mm)



Series 150
4" (100 mm) - 30" (750 mm)

Air/Vacuum Valves

Guaranteed Protection

1. Protection for pipelines
2. Eliminating risk of collapsing the line due to vacuum
3. Exhausts air when the line is filled
4. Allows air to re-enter immediately when the line drains

Plus these exclusive features at no extra cost:

5. Stainless steel floats - Guaranteed individually tested
6. ASTM quality materials guaranteed throughout
7. Every valve hydrostatically factory tested

Why and Where to Use Air/Vacuum Valves

An Air/Vacuum Valve has a large venting orifice and is used to exhaust large quantities of air from a pipeline when being filled or a deep well pump column when the pump is started.* Once the line is filled, the Air/Vacuum Valve closes and remains closed until the liquid is drained and pressure returns to atmospheric. The Air/ Vacuum Valve will then immediately open to allow air to re-enter the line and prevent a vacuum from developing.

Air/Vacuum Valves do not open to exhaust the small pockets of air which collect in the line while it is operating under pressure. We highly recommend Automatic Air Release Valves (AARV) be used in conjunction with Air/Vacuum Valves for maximum pipeline flow and pump efficiency. The AARV will eliminate constricting air pockets from forming at the high points of the pipeline.

The minimal cost for the Automatic Air Release Valves will quickly pay for itself in minimizing head loss through the pipeline. The result: energy cost savings!

Series 140H available for high pressure service specify operating pressure if below 20 psi (138 kpa).

***See bulletin 586 - Air Valves for Vertical Turbine Pumps**

Manufactured to AWWA C-512

ISO flange connections available

Optional:
Mushroom Cap
with built-in
bug screen

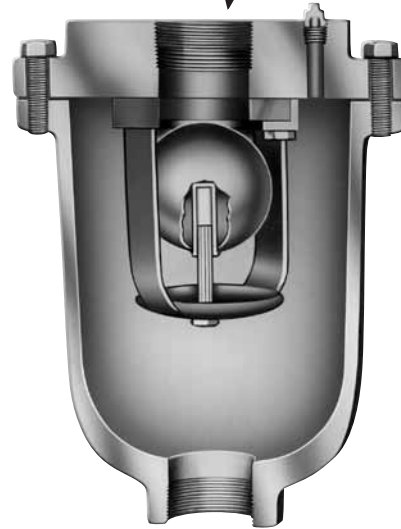
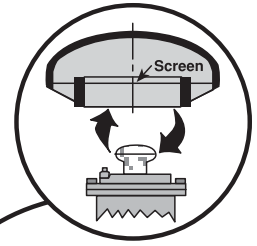

Series 140

1/2" (15 mm) through 3" (80 mm) outlets are NPT thread. It is good practice to install a mushroom cap into the threaded outlet for discharge protection.



Series 150

4" (100 mm) through 30" (750 mm) standard outlets are plain with a steel protector hood.

Optional threaded or flanged outlets available.

Physical Dimensions

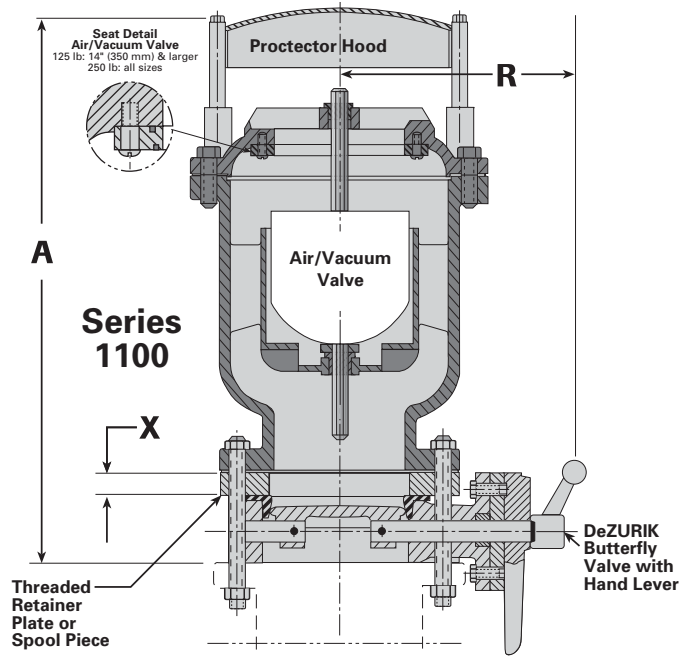

Model	Size	Height	Max. Dia.	Inlet	Outlet	Weight Lbs/Kg
141	.5\"/>					
142	1\"/>					
144	2\"/>					
146	3\"/>					
152	4\"/>					
153	6\"/>					
154	8\"/>					
155	10\"/>					
156	12\"/>					
157	14\"/>					
158	16\"/>					
159	18\"/>					
160	20\"/>					
162	24\"/>					

Inch
Millimeter

On sizes 4" (102 mm) and larger, the plain outlet comes with a protector hood, as illustrated. However, threaded or flanged outlets are available and recommended when valves are used inside the pump house.

Replace Shut-Off Valves with DeZURIK Butterfly Valves

Costs to excavate pipeline trenches can be greatly reduced by using DeZURIK Butterfly Valves for isolation instead of gate valves. DeZURIK Butterfly Valves are economical, reliable and much shorter, permitting a reduction in depth of trench. See Below.

Size	Model	Combination	A	R	X	No. Required & Size			
						Studs		Nuts	
						UNC	ISO	UNC	ISO
4\"/>									
6\"/>									
8\"/>									
10\"/>									
* 12\"/>									
* 14\"/>									
16\"/>									

Inch
Millimeter

* Uses spool piece

Additional Air Valve Information	Bulletin
Which Air Valve Should I Use?	610
Combination Air Valves	623
Air Valves for Vertical Turbine Pumps	586
Slow Closing Air and Vacuum Valves	613
Hydraulically Controlled Air/Vacuum Valves	7000

Where to Install

Typical Pipeline Showing its Hydraulic Gradient and the Position of Necessary APCO Air Valves.

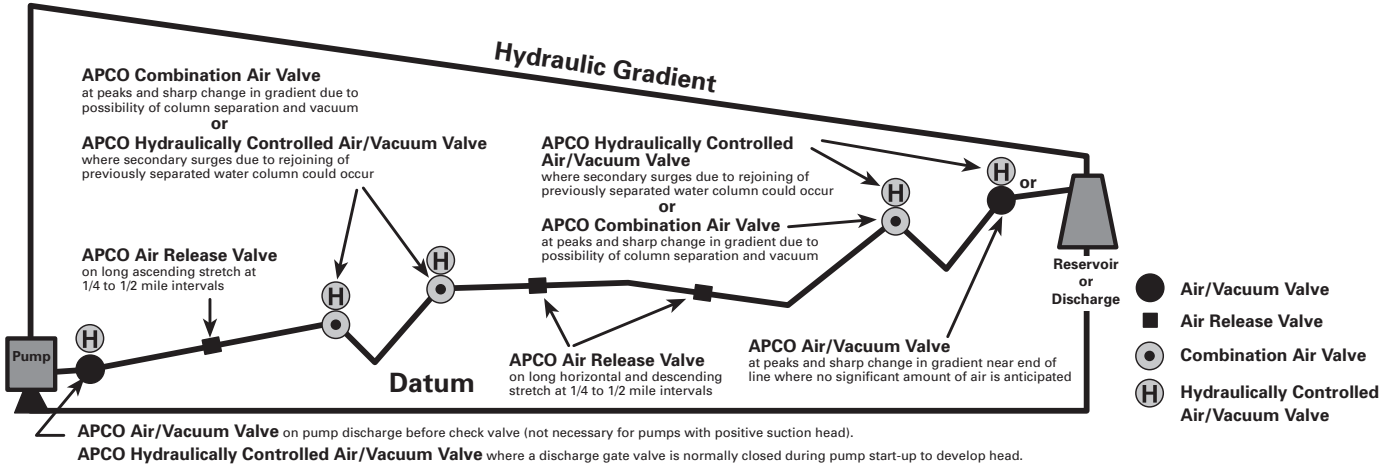

Performance Graphs For Air/Vacuum Valve

Air inflow/outflow thru valve in standard cubic feet of free air per second, (SCFS)

Inflow

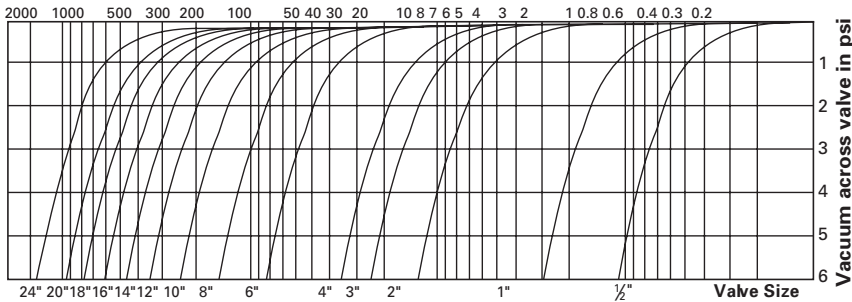

Test conducted by:
 Phillips Petroleum Company
 Engineering Department - Test Division
 Edmond Plant February 2, 1961

Southern Research Institute
 Birmingham, Alabama May 8, 1959

Outflow

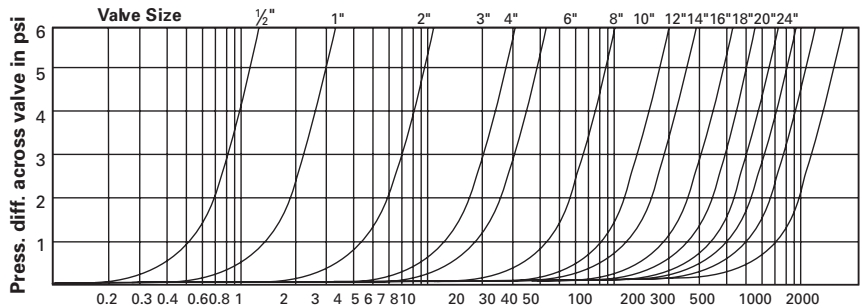

Curves shown are actual flow capacities at 14.7 psi barometric pressure and 70°F temperature based on actual test. These figures are not merely flow capacities across the orifice, but flow capacities across the entire valve. In the test set-up, air approach velocity is negligible, therefore actual flow capacity exceeds the values shown on chart.

Sizing Air/Vacuum Valves for Pipelines

General Explanation of Criteria Used

1. Calculate necessary valves independently for each high point on the line.
2. Consider the more severe of the two gradients adjacent to each high point.
3. Determine maximum rate of flow in cubic feet per second which can occur in this gradient during both the filling and draining of the line. Always be sure to take the highest possible rate of flow under either circumstance, draining or filling the pipeline.

To calculate rate of flow:

If line is being filled by a pump

$$\text{Rate of flow CFS} = \frac{\text{GPM of pump}}{449}$$

If the line is being drained by gravity

$$\text{Rate of flow in CFS} = 0.08666 (SD)^5 \frac{1}{2}$$

$$\text{Where } S = \text{Slope (in feet per foot of length)}$$

$$D = \text{Diameter of pipe (inches)}$$



**Use DeZURIK/
APCO slide rule air
valve computer
or APCO Apslide
Software**

4. Valve to be installed at this high point must release or re-enter the amount of air in CFS equal to the maximum possible flow of water in CFS immediately adjacent to this high point.
5. To economize in size of valves selected, final step is to determine the maximum pressure differential which can be tolerated across the orifice consistent with the required flow of air in CFS already determined.
6. To determine this maximum tolerable differential pressure, it is necessary to calculate if there is risk of line collapse from vacuum. This condition usually is present in thin-walled steel lines above 24". To calculate collapsing pressure for thin-walled-cylindrical pipe:

$$P = 12500000 \left(\frac{T}{D} \right)^3$$

$$\text{Where } P = \text{Collapsing pressure (PSI)}$$

$$T = \text{Thickness of pipe (inches)}$$

$$D = \text{Diameter of pipe (inches)}$$

This includes a Safety Factor of 4

7. For air flow in, use the maximum pressure differential thus calculated or 5 psi whichever is lower. Enter the graph with this differential (never greater than 5 psi) and the flow found during draining to select the appropriate valve to protect your line from collapse and water column separation due to vacuum.
8. Next enter the graph with the maximum rate at which the line can be filled and use a 2 psi differential pressure. This valve size is sufficient to vent all air from the line before valve closure. This ensures maximum performance from the line.
9. Compare the sizes calculated in steps 7 & 8. The larger size is correct for the protection of your system.
10. These valves should be installed on the high point with a shut-off valve below them.
11. The same procedure should be followed for each individual high point.
12. If the line lacks clearly defined high points or they are separated by long stretches of uniform gradient, it is recommended that the proper valves be selected as explained above and duplicate installations be made at regular intervals of $\frac{1}{4}$ to $\frac{1}{2}$ mile at the engineer's discretion.

To Ensure Maximum Capacity From The Pipeline:

When a line is in operation, air pockets collect both at the high point and for a distance down stream from the high point. To release the air, install the APCO Air/Vacuum Valves along with a 2" (50 mm) APCO No. 200 Air Release Valve at the high point and a second Air Release Valve a short distance down stream.

Typical Air Valve Manhole Installation

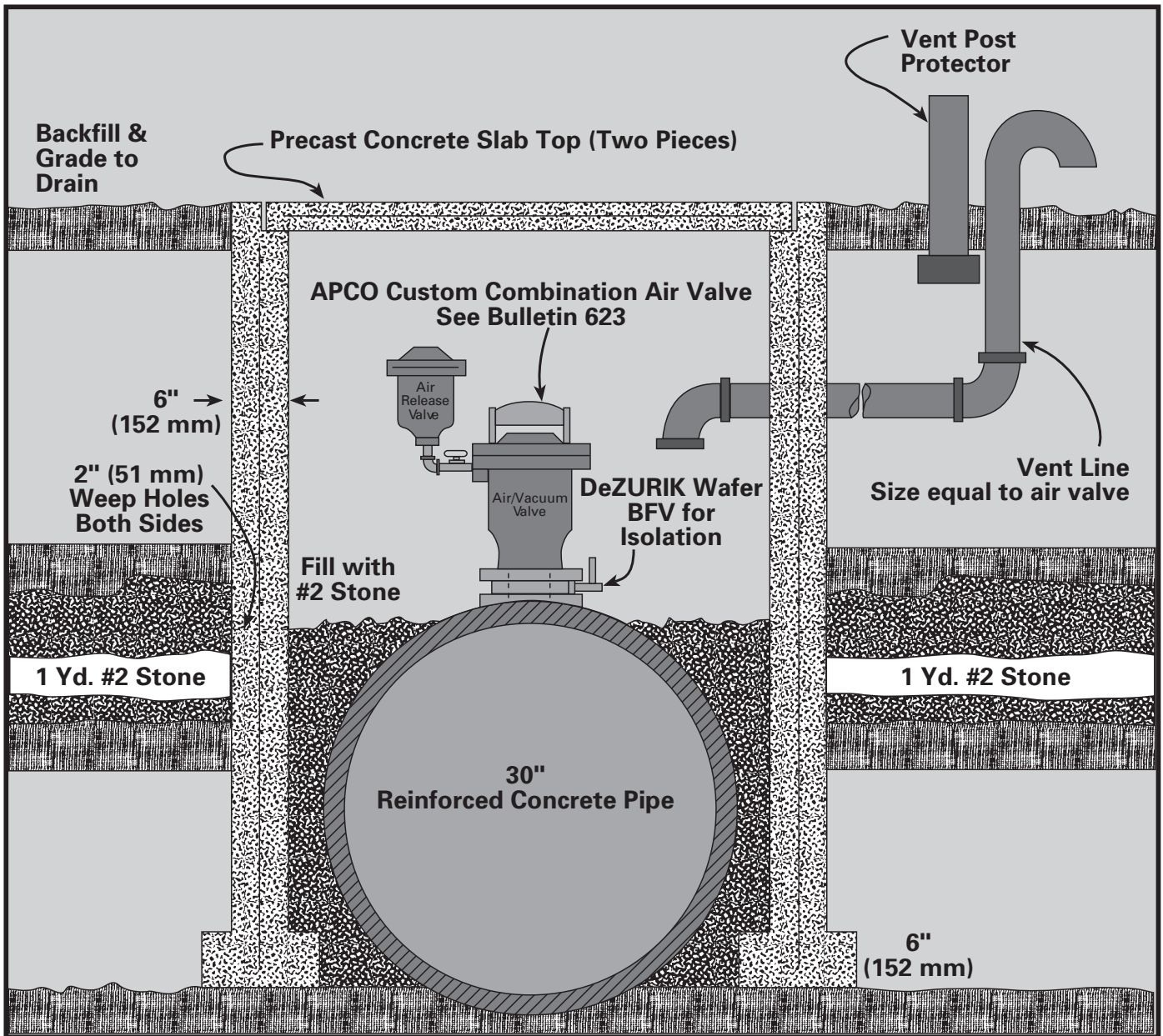

Specifications

The Air/Vacuum Valve shall be designed to allow large quantities of air to escape out the orifice when filling a pipeline and to close water tight when the liquid enters the valve. The Air/Vacuum Valve shall also permit large quantities of air to enter through the orifice when the pipeline is being drained to break the vacuum. The discharge orifice area shall be equal or greater than the inlet of the valve.

The valve shall consist of a body, cover, baffle, float and seat. The baffle will be designed to protect the float from direct contact of the rushing air and water to prevent the float from closing prematurely. The seat shall be fastened into the valve cover without distortion and shall be easily removed, if necessary. The float shall be stainless steel, and shall be center guided into the seat.

Air/Vacuum Valves shall be sizes 1/2" (15mm) through 3" (80mm) and shall have NPT threaded outlets for installation of street elbow or mushroom cap. Sizes 4" (100mm) through 30" (750mm) shall have plain outlet with steel protector hood.

All materials of construction shall be certified in writing to conform to ASTM specifications as follows:

Body and cover	Cast Iron	ASTM A126 Gr.B
	Ductile Iron	ASTM A536 GR 65-45-12
Float	Stainless Steel	ASTM A240
Seat	Buna-N	
Exterior paint	Universal Metal Primer	FDA approved for potable water contact
Protector hood	Steel	

Valve to be APCO Series 140/150 Air/Vacuum Valve.

Larger diameter valves may have alternate float designs.

Sales and Service

For information about our worldwide locations, approvals, certifications and local representative:

Web Site: www.dezurik.com E-Mail: info@dezurik.com



250 Riverside Ave. N. Sartell, Minnesota 56377 • Phone: 320-259-2000 • Fax: 320-259-2227

DeZURIK, Inc. reserves the right to incorporate our latest design and material changes without notice or obligation. Design features, materials of construction and dimensional data, as described in this bulletin, are provided for your information only and should not be relied upon unless confirmed in writing by DeZURIK, Inc. Certified drawings are available upon request.