

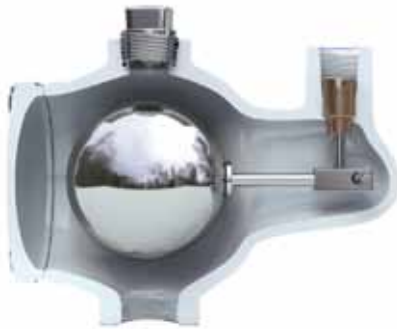

## APCO HVAC & FIRE VALVES



Series 55



Series 200A



Series 50



Series 600

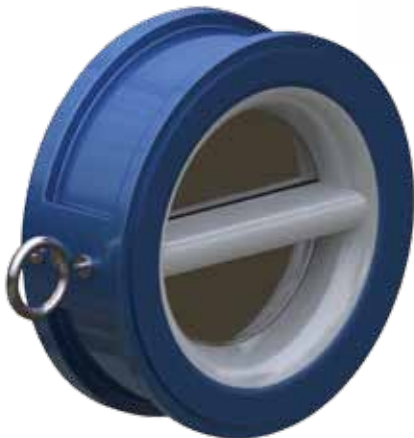

Series 9000



Series 300

# 55 Air Release Valve



Metal to Metal Seated

## Physical Dimensions

Height . . . . . 5" (127mm)  
 Width . . . . . 3.313" (84mm)  
 Length . . . . . 6.25" (159mm)  
 Orifice . . . . . 0.094" (2mm)  
 Inlet Size. . . . . 0.5" NPT (15mm)  
 Weight . . . . . 5 Lbs (2.3kg)

Maximum  
 Operating Pressure . . . . 175 PSI (1207kpa)  
 Test Pressure . . . . . 350 PSI (2413kpa)  
 Material . . . . . Cast Iron  
 Other Materials Available

## Specifications

The 55 ARV shall operate (open) under pressure and allow entrapped air to escape from a pipeline, pump, tank or hot water system. After air escapes out of the ARV orifice, the orifice shall close by means of a simple lever mechanism to prevent water from escaping. The orifice will then stay closed until more air accumulates inside and the opening cycle will repeat automatically. The needle shall be stainless steel, accurately guided into the seat orifice for tight shut-off. The seat shall be brass with a minimum .094" (2mm) orifice and a built-in ball check to prevent air from re-entering the system under negative conditions. The brass seat shall be replaceable without dismantling the main valve. The ARV must have a stainless steel float designed to withstand a pressure of 1000 psi (6895kpa) static.

The 55 ARV shall be **Factory Mutual approved** and **Underwriters Laboratories listed** for use on centrifugal fire pumps.

All materials of construction shall be certified in writing to conform to ASTM Specifications as follows:

Body & Cover	Cast Iron or Ductile Iron	ASTM A48, Class 30 ASTM A536 Gr. 65-45-12
Internal Levers	Bronze*	ASTM B584
Float & Needle	Stainless Steel	ASTM A240
Exterior Paint	Universal Metal Primer	FDA Approved for Potable Water Contact

\*Bronze components meet current lead-free requirements.

Other materials available.

Valve to be APCO Model 55 Air Release Valve.

## Centrifugal Fire Pumps

The 55 or 50 Air Release Valve (ARV) should be mounted on the pump volute, as shown in the illustrations to rid the pump of entrapped air. The 55 ARV is furnished with a vacuum ball which will permit air to pass out but not return. This is especially desirable to prevent air entering under vacuum conditions. (To ensure the centrifugal fire pump be primed, free of air and ready to deliver urgently needed water upon demand.) An automatic ARV must be installed on the volute of the fire pump to eliminate pockets of air, which can cause the pump to lose prime or become air bound. The 50 ARV does not include the vacuum ball check.

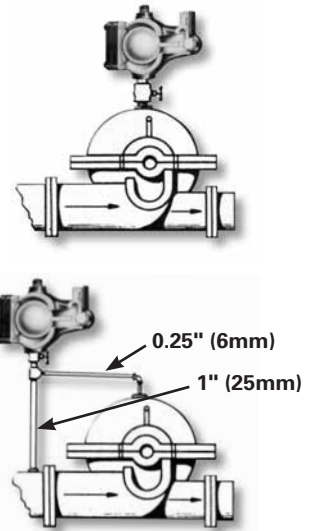

# 50 Air Release Valve



At all high points in a water line, air will accumulate and must be released. This is also true where a large amount of air is encountered as with air injection of chlorine into the water system. Air will accumulate and needs to be released.

The 50 ARV installed at these points will release the accumulated air to insure unrestricted flow of the water and minimize the problem of annoying and sometimes damaging effect of water hammer.

The standard 50 ARV with .094" (2mm) orifice will provide more than adequate venting for these installations.

## Physical Dimensions

Inlet Sizes . . . . .	0.5", 0.75", 1" NPT (15, 20, 25mm)
Height . . . . .	5.875" (149mm)
Width . . . . .	3.75" (95mm)
	125#                      250# Class                      Class
Orifice Size . . . . .	0.094"                      .063" 2mm                          1mm
Operating Pressure . . . . .	0-175 psi                      176-300 psi (0-1207kpa)                      (1213-2068kpa)

Specify when operating pressure below 8 psi (55kpa) is required.

## Specifications

The 50 ARV shall operate (open) under pressure and allow entrapped air to escape from a pipeline, pump, tank or hot water system. After air escapes out of the 50 ARV orifice, the orifice shall close by means of a simple lever mechanism to prevent water from escaping. The orifice will then stay closed until more air accumulates inside and the opening cycle will repeat automatically. The needle shall be Buna-N, accurately guided to the seat orifice by means of a stainless steel lever and needle arm for drop tight shut-off. The seat shall be stainless steel with a 0.094" (2mm) orifice to operate (open) up to 175 psi (1207kpa) or 0.063" (1mm) orifice for 300 psi (2068kpa). The 50 ARV shall have a stainless steel float designed to withstand a shock pressure of 1000 psi (6895kpa) static. The 50 ARV body shall have a 0.5" (15mm) NPT female threaded inlet and outlet, and be rated for 350 psi (2413kpa) test pressure. Materials of construction shall be certified to conform to ASTM specifications as follows:

The 50 Air Release Valve (ARV) is approved by Factory Mutual Research Corporation and Underwriters Laboratories listed for installation on centrifugal fire pumps.

Body & Cover	Cast Iron or Ductile Iron	ASTM A48, Class 30 ASTM A536 Gr. 65-45-12
Internal Levers	Stainless Steel	ASTM A240
Float	Stainless Steel	ASTM A240
Needle	Buna-N	
Exterior Paint	Universal Metal Primer	FDA Approved for Potable Water Contact

Valve to be APCO Model 50 Air Release Valve.

# Silent Check Valves

APCO Silent Check Valves (SCV) have been thoroughly tested by Factory Mutual Research Corporation. As a result, the 300 Series and 600 Series Valves can be used on hazardous fire fighting equipment and fire protection systems with assurance of performance. For such applications, insist on the Factory Mutual Guarantee label of approval on your SCV. Available on sizes as indicated.

## Series 300 Wafer Style Silent Check Valve



Dimensions for 125#/250# Class Valves								
Model	Size	Face to Face	No. of Bolts		Bolt Circle		Bolt Size	
			125#	250#	125#	250#	125#	250#
301	1" 25	2.063" 52	4	4	3.125" 79	3.5" 89	.5" x 4.25" 13 x 108	.625" x 4.5" 16 x 114
301.25	1.25" 30	2.063" 52	4	4	3.5" 89	3.875" 98	.5" x 4.25" 13 x 108	.625" x 4.5" 16 x 114
301.5	1.5" 40	2.375" 60	4	4	3.875" 98	4.5" 114	.5" x 4.75" 13 x 121	.75" x 5.25" 19 x 133
302	2" 50	2.625" 67	4	4	4.75" 121	5" 127	.625" x 5.25" 16 x 133	.625" x 5.5" 16 x 140
302.5	2.5" 65	2.875" 73	4	4	5.5" 140	5.875" 149	.625" x 5.75" 16 x 146	.75" x 6.5" 19 x 165
303	3" 80	3.125" 79	4	4	6" 152	6.625" 168	.625" x 6.25" 16 x 159	.75" x 7" 19 x 179
304*	4" 100	4" 102	8	8	7.5" 191	7.875" 200	.625" x 7" 16 x 178	.75" x 8" 19 x 203
305	5" 125	4.625" 117	8	8	8.5" 216	9.25" 235	.75" x 7.75" 19 x 197	.75" x 9" 19 x 229
306*	6" 150	5.5" 140	8	12	9.5" 241	10.625" 270	.75" x 8.75" 19 x 222	.75" x 10" 19 x 254
125 lb. ANSI Pressure Class								
308*	8" 200	6.5" 165	8	—	11.75" 298	—	.75" x 10" 19 x 254	—
310*	10" 250	8.25" 210	12	—	14.25" 362	—	.875" x 12.5" 22 x 318	—
250 lb. ANSI Pressure Class								
358	8" 200	6.5" 165	—	12	—	13" 330	—	.875" x 11.25" 22 x 286
360	10" 250	8.25" 210	—	16	—	15.25" 387	—	1" x 13.75" 25 x 349

Inch  
Millimeter

## Series 600 Globe Style Silent Check Valve

125# & 150# ANSI Pressure Casses						
Model	Size	Flange Dia.	Face to Face	Bolt Circle Dia.	Bolt Size	No. of Bolts
603	3" 80	7.5" 191	6" 152	6" 152	.625" 16	4
604*	4" 100	9" 229	7.25" 184	7.5" 191	.625" 16	8
605	5" 125	10" 254	8.5" 216	8.5" 216	.75" 19	8
606*	6" 150	11" 279	9" 229	9.5" 241	.75" 19	8
608*	8" 200	13.5" 343	10.125" 257	11.75" 298	.75" 19	8
610*	10" 250	16" 406	12" 305	14.25" 362	.875" 22	12
612*	12" 300	19" 483	14.25" 362	17" 432	.875" 22	12
614	14" 350	21" 533	15.75" 400	18.75" 476	1" 25	12
616	16" 400	23.5" 597	17.625" 448	21.25" 540	1" 25	16
618*	18" 450	25" 635	18.75" 476	22.75" 578	1.125" 29	16
620	20" 500	27.5" 699	20.625" 524	25" 635	1.125" 29	20
624	24" 600	32" 813	24" 610	29.5" 749	1.25" 32	20
630	30" 750	38.75" 984	29.25" 743	36" 914	1.25" 32	28
636	36" 900	46" 1168	45" 1143	42.75" 1086	1.5" 38	32
642	42" 1100	53" 1346	50" 1270	49.5" 1257	1.5" 38	36

Inch  
Millimeter

250# & 300# ANSI Pressure Casses						
Model	Size	Flange Dia.	Face to Face	Bolt Circle Dia.	Bolt Size	No. of Bolts
653	3" 80	8.25" 210	6" 152	6.625" 168	.75" 19	8
654	4" 100	10" 254	7.25" 184	7.875" 200	.75" 19	8
655	5" 125	11" 279	8.5" 216	9.25" 235	.75" 19	8
656	6" 150	12.5" 318	9" 229	10.625" 270	.75" 19	12
658	8" 200	15" 381	10.125" 257	13" 330	.875" 22	12
660	10" 250	17.5" 445	12" 305	15.25" 387	1" 25	16
662	12" 300	20.5" 521	14.25" 362	17.75" 451	1.125" 29	16
664	14" 350	23" 584	15.75" 400	20.25" 514	1.125" 29	20
666	16" 400	25.5" 648	17.625" 448	22.5" 572	1.25" 32	20
668	18" 450	28" 711	18.75" 476	24.75" 629	1.25" 32	24
670	20" 500	30.5" 775	20.625" 524	27" 686	1.25" 32	24
674	24" 600	36" 914	24" 610	32" 813	1.5" 38	24
680	30" 750	43" 1092	29.25" 743	39.25" 997	1.75" 44	28
686	36" 900	50" 1270	45" 1143	46" 1168	2.125" 54	32
692	42" 1100	57" 1448	50" 1270	52.75" 1340	2.25" 57	36

Inch  
Millimeter

# What Causes Water Hammer?

Conditions responsible for this phenomenon occur when a quantity of energy is suddenly released in a confined space. Energy is a function of mass times velocity and relating this to practical hydraulics means water hammer occurs when a body of water in motion in a pipe is suddenly stopped!

One of the most common occurrences is when a pump is shut down and the forward flow of water reverses (due to the influence of gravity) then starts to return back until stopped by the check valve.

Recognizing this, it becomes obvious that the secret to preventing water hammer due to flow reversal in a fire protection system is to use a check valve which will close before this reversal of flow can take place.

To meet a steadily growing problem, the Silent Check Valve (SCV) evolved. In designing this valve, all other characteristics were subordinated to the principle need that it must positively close before a reversal of flow takes place.

The SCV was therefore designed to open at approximately 0.25 - 0.5 psi (1.7 - 3.4kpa). This means that when a pump is shut down, the SCV will completely close while there is still a positive head on the suction side of approximately 0.5 psi (3.4kpa).

In this simple manner, the reverse flow, which is a cause of the trouble in water hammer conditions, never gets a chance to start (as in contrast to the Swing Check, Tilting Disc Check or Double Door Check Valves).

The graph to the right shows the relative head losses for various types of check valves.

More engineers are specifying APCO SCVs for their fire pump systems to protect the installation against damaging water hammer. We are confident this number will continue to grow as these pertinent facts become better known.

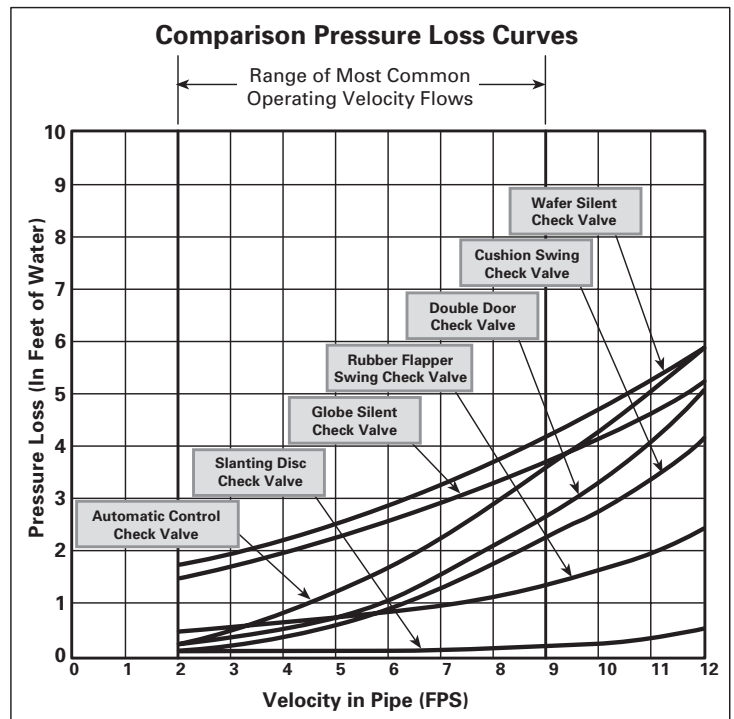

# Specifications

## Series 300 Wafer Style Silent Check Valve

Wafer Style Silent Check Valves (SCV) shall be designed with cast or ductile iron bodies, stainless steel seat, plug and spring. The valve plug must be center guided at both ends with a through integral shaft and spring loaded for silent shut-off operation.

The spring must be helical or conical. Seat and plug shall be hand replaceable in the field for ease of maintenance. The flow area through the body shall be equal to or greater than the cross-section area of the equivalent pipe size. Check valve must be capable of silent operation when installed in vertical or horizontal position – flow up or down.

All materials of construction shall be certified in writing to conform to ASTM specifications as follows:

Body	Cast Iron	ASTM A126 Gr.B
	or Ductile Iron	ASTM A536 Gr. 65-45-12
Plug & Seat	Stainless Steel	ASTM A296
Spring	Stainless Steel	ASTM A276 T316
Exterior Paint	Universal Metal Primer	FDA Approved for Potable Water Contact

Other materials available.

Valve to be APCO Series 300 1" - 10" (25 - 250mm) Silent Check Valve – Wafer Style, Factory Mutual approved – sizes 4", 6", 8" and 10" (100, 150, 200, 250mm) (125 Lb. Class), sizes 4", 6" (100, 150mm) (250 Lb. Class)

## Series 600 Globe Style Silent Check Valve

Globe Style Silent Check Valve (SCV) shall be designed with cast iron bodies, stainless steel seat, plug and spring. The valve plug must be center guided at both ends with a through integral shaft and spring loaded for silent shut-off operation.

The spring must be helical or conical. The seat and plug shall be hand replaceable in the field for ease of maintenance. The flow area through the body shall be equal to or greater than the cross-sectional area of the equivalent pipe size.

All materials of construction shall be certified in writing to conform to ASTM specifications as follows:

Body	Cast Iron	ASTM A126 Gr.B
	or Ductile Iron	ASTM A536 Gr. 65-45-12
Plug & seat	Stainless Steel	ASTM A296
Spring	Stainless Steel	ASTM A276 T316
Exterior paint	Universal Metal Primer	FDA Approved for Potable Water Contact

Other materials available.

Valve to be APCO Series 600 3" - 42" (80 - 1100mm) Silent Check Valves  
Factory Mutual approved – sizes 4", 6", 8", 10", 12" and 18" (100, 150, 200, 250, 300, 450mm).

For more comparison information about various type check valves, see Bulletin #769 "APCO Check Valve Guide."

# HVAC Air Release Valves

The vast majority of buildings (over two stories) utilizing a central hot water and chilled water heating/cooling system require reliable positive shut-off Air Release Valves. This application demands rugged long lasting type APCO Air Valves.

The cheap variety leak and don't measure up to the requirements of this application.

The Air Valves ideally suited to this application are the APCO Model 200A with Vacuum Check and 50 Air Release Valve.

The purpose of the 50 Air Release Valve is to rid the piping system of small pockets of air which accumulate at all high points, that otherwise would restrict or stop flow.

The purpose of the 200A with Vacuum Check is to release air, particularly during initial filling of the water system, but also after filling when entrained air from the boiler or heat exchanger must be vented to atmosphere from the air separator tank.

The 200A is equipped with a Vacuum Check to prevent air from re-entering the air separator.



50 Air Release Valve



200A W/Vacuum Check Air Release Valve



APCO  
200A with Vacuum Check  
Air Release Valve  
.188" (5mm) Orifice  
High Capacity

APCO  
50 Air Release Valve  
with 0.094" (2mm) Orifice

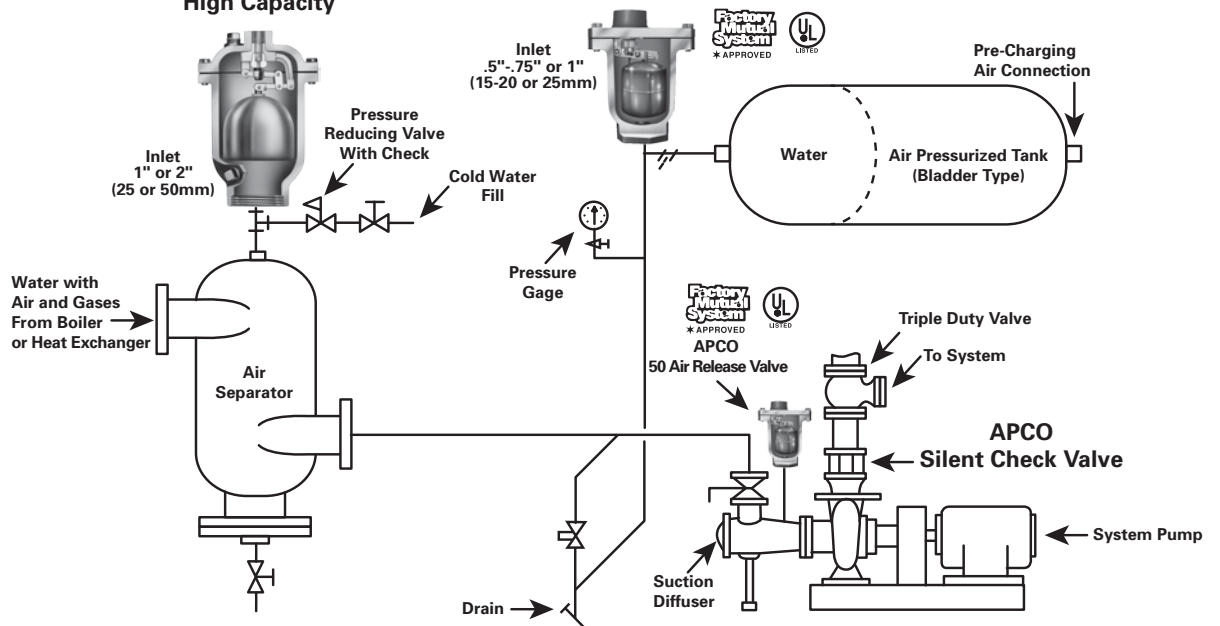

Typical Air Bag Tank Installation with Air Separator

# Series 9000 Double Door Check Valves Wafer & Lug Style

The Double Door Check Valve (DDCV) Series 9000 is approved by Factory Mutual Research Corporation for installation on the discharge of centrifugal fire pumps.

This type check valve is commonly specified and used for many years on centrifugal fire pumps. The primary reasons for the DDCV success is the unique short face to face length, the low purchase cost and the low installation cost.

It will be obvious why APCO DDCVs are the most economical to purchase and install after reading the following comparison:

A 12" (300mm) Swing Check Valve of conventional design (ie: as manufactured by APCO), Model 6012, 125# Class has a face to face length of 28" (711mm).

A 12" (300mm) APCO DDCV, Model 9012, 125# Class has a face to face length of 7.125" (180mm).

The 12" (300mm) SCV 125# Class weighs 900 lbs (408kg).

The 12" (300mm) APCO DDCV 125# Class weighs 125 lbs (57kg)

The result is a great reduction in the mass of raw materials and a much lower cost.

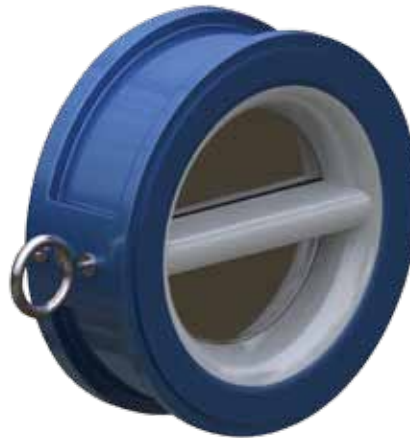

Sizes 4", 6", 8", 10", & 12" (100, 150, 200, 250, 300mm)  
125 and 250# Class Ratings

\* This size valve underwriters laboratories listed  
8", 10" & 12" (200, 250, 300mm) 125# class only

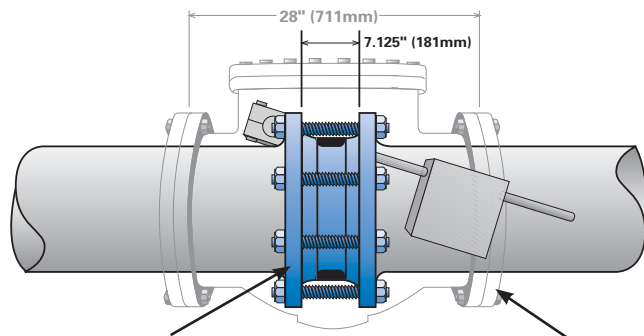

DDCV requires one set of bolts and nuts to install.

Conventional style Swing Check Valve requires two sets of bolts and nuts to install and is considerably larger and heavier.

# Install on Centrifugal Fire Pump

Double Door Check Valves (DDCVs) have excellent performance records on centrifugal fire pump installations. Fire pump piping systems are heavily designed to withstand the fast closing action of valves as results with the Double Door Check type Valves.

It is good to remember that while the DDCV has non-slam characteristics and is fast closing, it is not silent! If silent operation is required, use APCO Silent Check Valves. No single Check Valve is all serving. Consider all aspects of your fire pumping system, including the potential for water hammer before making your check valve choice.

DDCVs are lightweight because they are extremely compact in laying length. Therefore, sizes to 4" and 6" (100, 150mm) are easily installed by hand. Sizes 8", 10" and 12" (200, 250, 300mm) come furnished with a lifting eye bolt to simplify installation

DDCVs can be installed horizontally or vertically (flow up) to conserve valuable piping space. Once installed between flanges, the DDCV has more rigidity than a heavy steel walled pipe of the same length, therefore valve supports are not needed.

The important feature of the Threaded Lug DDCV is its use as a block valve. Installed between flanges, the bolts coming through the pipe flange screw into the threaded lugs on the check valve body. In this manner, the check valve is securely fastened to the mating flange of the pipeline. This feature allows repairing upstream of the check valve, while the check valve remains in place as a block valve to the system.

Valve must be installed with hinge pin in the vertical position for horizontal flow applications.

# Dimensions - Series 9000

Size	Class	A	B	C	D	E	Wt.
2" 50	125	4" 102	2.125" 54	2.563" 65	1.875" 48	.188" 5	5 2
	150	4" 102	2.375" 60	2.563" 65	1" 25	—	6 3
	250	4.25" 108	2.125" 54	2.563" 65	1.875" 48	.188" 5	8 4
	300	4.25" 108	2.375" 60	2.563" 65	1" 25	—	8 4
2.5" 65	125	4.75" 121	2.375" 60	3.125" 79	2.375" 60	.375" 10	8 4
	150	4.75" 121	2.625" 67	3.125" 79	2" 51	.25" 6	9 4
	250	5" 127	2.375" 60	3.125" 79	2.375" 60	.375" 10	11 5
	300	5" 127	2.625" 67	3.125" 79	2" 51	.25" 6	12 5
3" 80	125	5.25" 133	2.625" 67	3.5" 89	3" 76	.5" 13	10 5
	150	5.25" 133	2.875" 73	3.5" 89	2.75" 70	.25" 6	11 5
	250	5.75" 146	2.625" 67	3.5" 89	3" 76	.5" 13	15 7
	300	5.75" 146	2.875" 73	3.5" 89	2.75" 70	.25" 6	16 7
* 4" 100	125	6.75" 171	2.625" 67	4.5" 114	4.375" 111	1.125" 29	12 5
	150	6.75" 171	2.875" 73	4.5" 114	4" 102	.875" 22	14 6
	250	7" 178	2.625" 67	4.5" 114	4.375" 111	1.125" 29	20 9
	300	7" 178	2.875" 73	4.5" 114	4" 102	.875" 22	22 10
5" 125	125-150	6.75" 171	2.625" 67	4.5" 114	4.375" 111	1.125" 29	12 5
	250-300	8.375" 213	3.25" 83	5.563" 141	5" 127	1.25" 32	33 15
* 6" 150	125	8.625" 219	3.75" 95	6.625" 168	6" 152	1.5" 38	20 9
	150	8.625" 219	3.875" 98	6.625" 168	5.875" 149	1.375" 35	22 10
	250	9.75" 248	3.75" 95	6.625" 168	6" 152	1.5" 38	40 18
	300	9.75" 248	3.875" 98	6.625" 168	5.875" 149	1.375" 35	44 20
* † 8" 200	125-150	10.875" 276	5" 127	8.75" 222	7.75" 197	1.5" 38	52 24
	250-300	12" 305	5" 127	8.75" 222	7.75" 197	1.5" 38	70 32
* † 10" 250	125	13.25" 337	5.5" 140	10.75" 273	10" 254	2.625" 67	63 29
	150	13.25" 337	5.75" 146	10.75" 273	9.75" 248	2.375" 60	100 45
	250	14.125" 359	5.5" 140	10.75" 273	10" 254	2.625" 67	110 50
	300	14.125" 359	5.75" 146	10.75" 273	9.75" 248	2.375" 60	115 52

Inch lbs  
Millimeter kg

\* FM - valves are factory mutual approved (125 & 250 lb.).  
† This size valve Underwriters Laboratories listed (125 lb.).

Note: Two or more springs used on sizes 14" (350mm) and larger.

Size	Class	A	B	C	D	E	Wt.
* † 12" 300	125-150	16" 406	7.125" 181	12.75" 324	10.875" 276	2.625" 67	150 68
	250-300	16.5" 419	7.125" 181	12.75" 324	10.875" 276	2.625" 67	220 100
14" 350	125-150	17.625" 448	7.25" 184	14" 356	13" 330	3.5" 89	220 100
	250-300	19" 483	8.75" 222	14" 356	12" 305	2" 51	440 200
16" 400	125-150	20.125" 511	7.5" 191	16" 406	15" 381	4.25" 108	275 125
	250-300	21.5" 546	9.125" 232	16" 406	14" 356	2.625" 67	550 249
18" 450	125-150	21.5" 546	8" 203	18" 457	17" 432	4.875" 124	300 136
	250-300	23.375" 594	10.375" 264	18" 457	16" 406	2.5" 64	665 302
20" 500	125	23.25" 591	8.375" 213	20" 508	18" 457	6.75" 171	325 147
	150	23.75" 603	8.625" 219	20" 508	18" 457	6.5" 165	490 222
	250	25.625" 651	11.5" 292	20" 508	17" 432	3.625" 92	450 204
	300	25.625" 651	11.5" 292	20" 508	17" 432	3.625" 92	800 363
24" 600	125-150	28.125" 714	8.75" 222	24" 610	22.625" 575	8.875" 225	700 318
	250-300	30.375" 772	12.5" 318	24" 610	21" 533	5.125" 130	1135 515
30" 750	125-150	34.625" 879	12" 305	30" 762	28.625" 727	11.125" 283	1100 499
	250-300	37.25" 946	14.5" 368	30" 762	27.375" 695	8.625" 219	1400 635
36" 900	125-150	41.125" 1045	14.5" 368	36" 914	34" 864	12.375" 314	1520 689
	250-300	43.75" 1111	18.875" 479	36" 914	33" 838	8" 203	1900 862
42" 1100	125-150	47.875" 1216	17" 432	42" 1067	40.375" 1026	15.125" 384	3000 1361
	250-300	50.625" 1286	22.375" 568	42" 1067	39" 991	9.75" 248	3500 1588
48" 1200	125-150	54.375" 1381	20.625" 524	48" 1219	46.625" 1184	16.875" 429	4500 2041
	250-300	58.625" 1489	24.75" 629	48" 1219	45.625" 1159	12.75" 324	5500 2495
54" 1400	125-150	60.875" 1546	21.25" 540	54" 1372	52.875" 1343	19.625" 498	6700 3039
60" 1500	125	67.25" 1708	25" 635	59.5" 1511	50" 1270	16" 406	7500 3402

Inch  
Millimeter

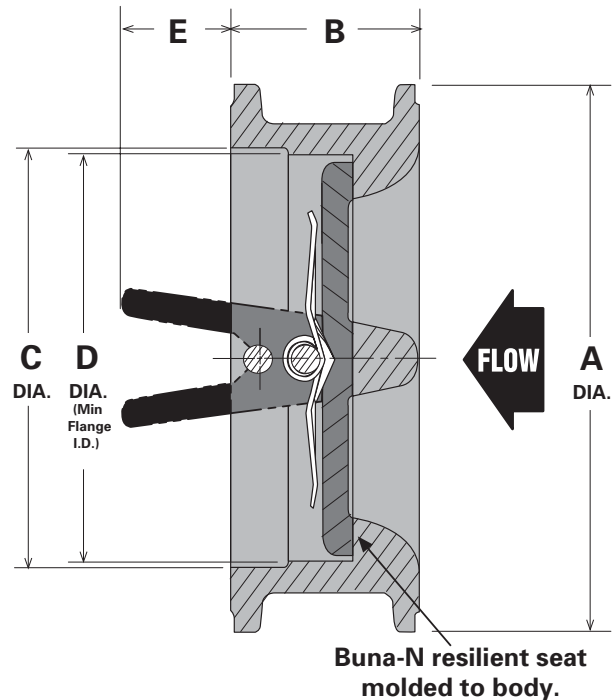

# Operation

The Double Door Check Valve (DDCV) is held closed by the legs of a torsion spring. Flow (head) from the pump causes the DDCV to open. Conversely, when the pump is stopped, flow decay occurs and at a point near zero velocity the force from the legs of the torsion spring quickly closes the DDCV.

# Resilient Seating

Standard seal materials on all APCO DDCVs is Buna-N. The sealing principle is similar to that of a static O-ring. Shut off is completed when the doors swing closed against the O-ring and compression of the seal occurs due to the downstream pressure in the system.

Buna-N has been successfully used for seals and seats in valves for many years. Buna-N has excellent water, oil and gas resistance and generally can be used in temperatures -70° to +250°F (-57° to 121° C). For higher temperatures other materials can be recommended.

# Specifications

The DDCV shall be compact Wafer design, to fit between ANSI flanges.

The Check Valve doors shall be spring loaded, normally closed, by means of one or more heavily duty stainless steel torsion springs. Flow from the pump shall cause the doors to open and upon pump shut down, the torsion spring will shut the doors before reverse flow starts and at a point of zero velocity for non-slam closure.

Seating shall be resilient and water tight. The seating element shall be Buna-N molded to the body.

Valves 8" (200mm) and larger shall be fitted with a lifting eye bolt for installation purposes.

Valve exterior to be painted with Universal Metal Primer as accepted by the FDA for use in contact with potable water.

All materials of construction shall be certified in writing to conform to ASTM specifications as follows:

Body	Select 1	{	Ductile Iron	ASTM A536
			Cast Steel	ASTM A216 WCB
			Cast Iron	ASTM A126 Gr.B
Doors	Select 1	{	Ductile Iron	ASTM A536
			w/ Al. Bronze Facing	ASTM B148, Alloy 952
			Cast Steel	ASTM A216 WCB
			Stainless Steel	ASTM A296
Sealing Element			Buna-N	
Torsion Spring			Stainless Steel	T316
Hinge Shaft			Stainless Steel	T316
Stop Shaft			Stainless Steel	T316

### Other materials also available.

Valve to be Series 9000 Double Door Check Valve, Factory Mutual approved - sizes 4", 6", 8", 10" and 12" (100, 150, 200, 250, 300mm) – and valve sizes 8", 10" and 12" (200, 250, 300mm) are Underwriters Laboratories listed. All valves conform to API standards.

## **Sales and Service**

For information about our worldwide locations, approvals, certifications and local representative:

Web Site: [www.dezurik.com](http://www.dezurik.com) E-Mail: [info@dezurik.com](mailto:info@dezurik.com)



250 Riverside Ave. N. Sartell, Minnesota 56377 • Phone: 320-259-2000 • Fax: 320-259-2227

*DeZURIK, Inc. reserves the right to incorporate our latest design and material changes without notice or obligation. Design features, materials of construction and dimensional data, as described in this bulletin, are provided for your information only and should not be relied upon unless confirmed in writing by DeZURIK, Inc. Certified drawings are available upon request.*