



DeZURIK DOUBLE-ACTING
HYDRAULIC CYLINDER
FOR T-SERIES ACTUATORS

DeZURIK

Double-Acting Hydraulic Cylinder for T-Series Actuators

Instructions

These instructions provide information about hydraulic cylinders. They are for use by personnel who are responsible for installation, operation and maintenance of hydraulic cylinders.

Safety Messages

All safety messages in the instructions are flagged with an exclamation symbol and the word Caution, Warning or Danger. These messages indicate procedures that must be followed exactly to avoid equipment damage, personal injury or death.

Safety label(s) on the product indicate hazards that can cause equipment damage, personal injury or death. If a safety label becomes difficult to see or read, or if a label has been removed, please contact DeZURIK for replacement label(s).



WARNING!

Personnel involved in the installation or maintenance of valves should be constantly alert to potential emission of pipeline material and take appropriate safety precautions. Always wear suitable protection when dealing with hazardous pipeline materials. Handle valves, which have been removed from service with suitable protection for any potential pipeline material in the valve.

Inspection

Your Hydraulic Cylinder has been packaged to provide protection during shipment; however, it can be damaged in transport. Carefully inspect the unit for damage upon arrival and file a claim with the carrier if damage is apparent.

Parts

Recommended spare parts are listed on the assembly drawing. These parts should be stocked to minimize downtime.

Order parts from your DeZURIK sales representative, or directly from DeZURIK. When ordering parts, please include the 7-digit part number and 4-digit revision number (example: **9999999R000**) located on the data plate attached to the valve assembly. Also include the part name, the assembly drawing number, the balloon number and the quantity stated on the assembly drawing.

DeZURIK Service

DeZURIK service personnel are available to install, maintain and repair all DeZURIK products. DeZURIK also offers customized training programs and consultation services.

For more information, contact your local DeZURIK sales representative or visit our website at www.dezurik.com.

Table of Contents

Description - - - - -	4
Supply - - - - -	4
Lubrication - - - - -	4
Packing Adjustment- - - - -	4
Closed Position Adjustment - - - - -	4
Cylinder Removal - - - - -	4
Cylinder Installation - - - - -	5
Cylinder Repair Kit Installation- - - - -	6

Description

The double-acting hydraulic cylinder is used to operate a T-Series actuator.



WARNING!

This cylinder is a pressure-containing vessel. Release pressure from both ends of the cylinder before attempting any disassembly or repair. Failure to release pressure from both ends before disassembling could result in personal injury.

Supply

Maximum cylinder supply pressure is 100 psi.

Lubrication

The cylinder does not require routine maintenance lubrication. If the cylinder is rebuilt, lubricate all seals, O-rings and the inside of the cylinder tube using one of these lubricants.

- Dow Corning Molykote No. 44 (**recommended**)
- Shell Retinax AM (alternate)
- Shell Lithall MDS (alternate)

Packing Adjustment

Tighten the packing nuts only when packing leakage occurs. Tighten the nuts just until leakage stops. Over tightening the nuts will result in premature packing wear.

Closed Position Adjustment

The set screw in the cylinder cap is the adjustable closed position stop. To adjust the stop, follow these steps:

1. Turn the stop screw five full revolutions counterclockwise.
2. Close the valve. The valve closed position is described in the Valve Instruction.
3. Pressurize the cylinder port nearest the actuator housing.
4. Loosen the lock nut on the closed position stop, then turn the stop screw in until resistance is felt as the stop screw contacts the piston rod.
5. Make sure the thread seal is in place, then tighten the lock nut on the stop screw.

Cylinder Removal

To remove the cylinder from the actuator, the actuator must be partially disassembled. To do this, you should have the Actuator Instructions on hand to use as reference. Follow these steps to remove the cylinder from the actuator.

Cylinder Removal (continued)

1. Discontinue pipeline flow. There cannot be flow in the pipeline at any time while the cylinder is off the actuator.
2. If the actuator is powered, disconnect and lock out the pneumatic, hydraulic or electrical power to prevent accidental operation of the actuator.



WARNING!

Moving parts from accidental operation of power actuator can cause personal injury or equipment damage. Disconnect and lock out power to actuator before servicing.

3. Remove the actuator cover screws and cover.
4. Remove the guide rail screws and guide rail(s).
5. Remove the stay pin from the piston rod.
6. Remove the screws securing the cylinder to the actuator housing, and then unscrew the cylinder from the yoke nut and stop nut.

Cylinder Installation

To mount the cylinder on the actuator, some information will be required from the Actuator Instruction.

1. Screw the cylinder into the yoke nut and stop nut. Figure 1 shows the correct distance from the stay pinhole to the yoke nut.

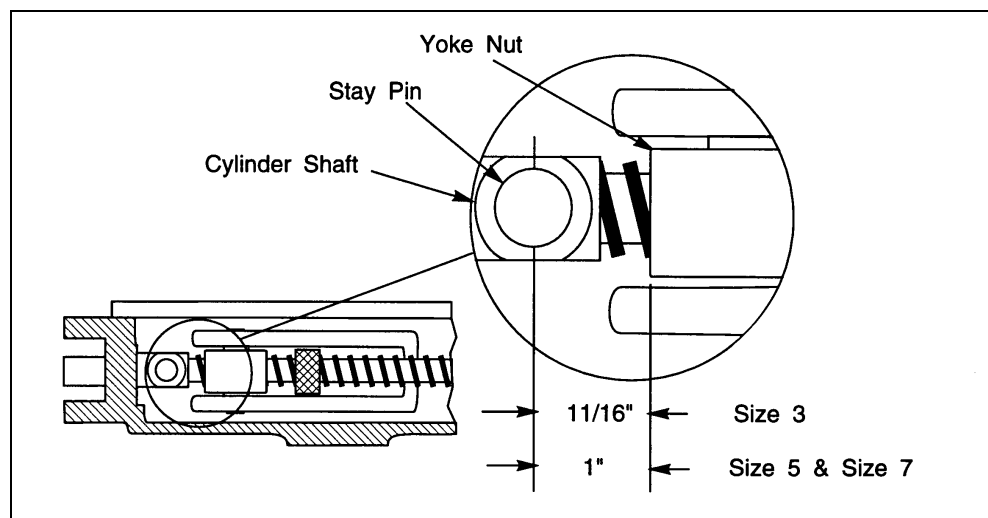

Figure 1- Distance from Stay Pin Hole to Yoke Nut

2. Push the cylinder in until it contacts the actuator housing. Fasten the cylinder to the housing with screws and lockwashers.
3. Push the stay pin into the hole in the piston rod.
4. Install the guide rail(s) and secure in place.

Cylinder Installation (continued)

5. Perform the Open and Closed Position Stop Adjustments as described in the Actuator Instruction.
6. Apply lubrication to the inside of the actuator as described in the LUBRICATION Section of the Actuator Instruction.
7. Install the gasket and cover on the actuator housing.
8. If the actuator is a powered actuator, reconnect power to the actuator.

Cylinder Repair Kit Installation

It is easier to rebuild the cylinder if it is left mounted on the actuator; to install the cylinder repair kit components, follow these steps.

1. Relieve the pipeline pressure and the cylinder pressure.



WARNING!

This cylinder is a pressure-containing vessel. Release pressure from both ends of the cylinder before attempting any disassembly or repair. Failure to release pressure from both ends before disassembling could result in personal injury.

2. If the actuator is powered, disconnect and lock out the pneumatic, hydraulic, or electrical power to prevent accidental operation of the actuator.



WARNING!

Moving parts from accidental operation of power actuator can cause personal injury or equipment damage. Disconnect and lock out power to actuator before servicing.

3. Disconnect the tubing from the cylinder.
4. Remove the nuts and washers from the tie rods.
5. Remove the cylinder cap from the cylinder.
6. Remove the O-ring from the cylinder cap.
7. Pull the cylinder tube off the piston. The cylinder tube will come off easier if you rotate it while pulling it off the piston.
8. Unscrew the nut holding the piston on the piston rod, and then slide the piston off.
9. Take the piston seal and O-ring off the piston.
10. Remove the four screws fastening the cylinder head to the adapter, then slide the cylinder head (with gland and packing) off the piston rod.
11. Take the O-ring off the cylinder head.
12. Remove the gland nuts, and then slide the gland and packing from the cylinder head.

Cylinder Repair Kit Installation (continued)

13. Remove the scrapers from the cylinder head and gland. Figure 2 shows the locations of the scrapers.
14. Thoroughly clean all components that will be reused.
15. Push new scrapers into the head and gland until they bottom out in the counterbores. The open side of the scraper should face away from the counterbore (see Figure 2).

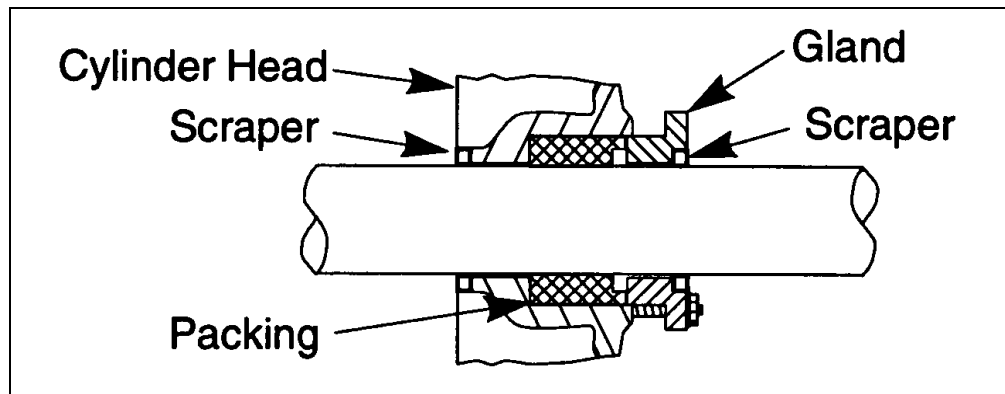

Figure 2 – Cylinder Repair Component Locations

16. Slide new packing, and the gland onto the piston rod.
17. Push the cylinder head on the piston rod so the packing pushes into the counterbore in the cylinder head.
18. Line up the holes in the gland with the studs in the cylinder head and push the cylinder head into place. Tighten the packing nuts finger tight plus 1/2 additional turn. These nuts must be tightened after the cylinder is pressurized.
19. Thoroughly lubricate a new O-ring and stretch it into the groove in the cylinder head.
20. Place the piston on the piston rod and secure in place with the nut.
21. Lubricate the new piston O-ring and install in the groove in the piston. After the O-ring is installed, slide the new piston seal in the wide groove in the piston.
22. Thoroughly lubricate the outside of the piston and the inside of the cylinder tube. Slide the tube onto the piston; rotate the tube while pushing it on.

Note: The tube will push on easier if one or two of the tie rods are removed and the tube is held at a 45 angle while pushing it on (see Figure 3).

Cylinder Repair Kit Installation (continued)

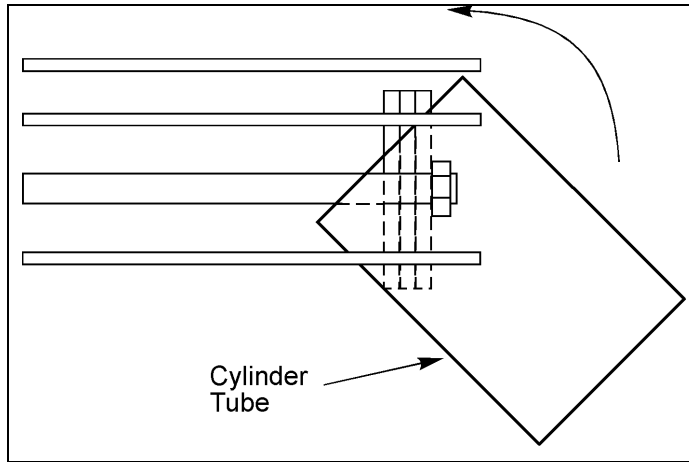

Figure 3 – Cylinder Tube Installation

- 23. Lubricate a new O-ring and stretch it into the groove in the cylinder cap.
- 24. Slide the cylinder cap into the cylinder tube. Place lockwashers and nuts on the tie rods; tighten the nuts in a crisscross pattern to the torque specified in Table A.

Table A: Tie Rod Nut Torque

Cylinder Size	Torque		
	(ft lbs)	(cm/kg)	(Nm)
3" & 4"	12	175	16
6" & 8"	16	225	22
10" & 12"	20	275	27

- 25. If the cylinder was removed from the actuator, reinstall the cylinder as described in the CYLINDER INSTALLATION Section of this Instruction.
- 26. If the actuator is a powered actuator, reconnect power to the actuator.
- 27. After the cylinder has been pressurized, check for packing leakage; if leakage is observed, tighten the packing nuts just until leakage stops. Over tightening the nuts will result in premature packing wear.