



DeZURIK R3 POWERRAC™ CYLINDER ACTUATOR

Instructions

These instructions provide information about the R3 PowerRac Cylinder Actuators. They are for use by personnel who are responsible for installation, operation and maintenance of R3 PowerRac Cylinder Actuators.

Safety Messages

All safety messages in the instructions are flagged with an exclamation symbol and the word Caution, Warning or Danger. These messages indicate procedures that must be followed exactly to avoid equipment damage, personal injury or death.

Safety label(s) on the product indicate hazards that can cause equipment damage, personal injury or death. If a safety label becomes difficult to see or read, or if a label has been removed, please contact DeZURIK for replacement label(s).



WARNING!

Personnel involved in the installation or maintenance of valves should be constantly alert to potential emission of pipeline material and take appropriate safety precautions. Always wear suitable protection when dealing with hazardous pipeline materials. Handle valves, which have been removed from service with suitable protection for any potential pipeline material in the valve.

Inspection

Your R3 PowerRac Cylinder Actuator has been packaged to provide protection during shipment; however, it can be damaged in transport. Carefully inspect the unit for damage upon arrival and file a claim with the carrier if damage is apparent.

Parts

Recommended spare parts are listed on the assembly drawing. These parts should be stocked to minimize downtime.

Order parts from your local DeZURIK sales representative, or directly from DeZURIK. When ordering parts, please include the 7-digit part number and 4-digit revision number (example: **9999999R000**) located on the data plate attached to the valve assembly. Also include the part name, the assembly drawing number, the balloon number and the quantity stated on the assembly drawing.

DeZURIK Service

DeZURIK service personnel are available to install, maintain and repair all DeZURIK products. DeZURIK also offers customized training programs and consultation services.

For more information, contact your local DeZURIK sales representative or visit our website at www.dezurik.com.

Table of Contents

Description - - - - -	4
Installation - - - - -	4
Operation - - - - -	4
Lubrication - - - - -	4
Open and Closed Position Stops	4
Removing Actuator From Valve - - - - -	7
Actuator Disassembly - - - - -	7
Actuator Reassembly - - - - -	8
Mounting Actuator on Valve - - - - -	11
Changing Mounting Position of Actuator on Valve - - - - -	12
Lockable Model - - - - -	12
<i>Unlocked Condition</i> - - - - -	12
<i>Locked: Closed Position</i> - - - - -	13
<i>Locked: Closed Position</i> - - - - -	13
Troubleshooting - - - - -	15

DeZURIK

R3 PowerRac™ Cylinder Actuator

Description

The R3 PowerRac Cylinder Actuator is a quarter-turn double-acting enclosed rack and gear cylinder actuator. The actuator is used for on-off or modulating control of butterfly valves and other valves that have a square or double-D shaft connection. A choice of an 8" (200 mm) or a 10" (250 mm) diameter cylinder is offered. A lockable model is available as an option.

Installation

The actuator requires two pneumatic connections— one to each port on opposite ends of the cylinder. Air to the connection closest to the actuator drives the actuator clockwise, towards the “shut” position on the dial; air to the connection farthest from the actuator drives the actuator counterclockwise, towards the “open” position on the dial. The 8" (200 mm) cylinder has ½" NPT connections, and the 10" (250 mm) cylinder has ¾" NPT connections.

Operation

The R3 PowerRac Cylinder Actuator is powered pneumatically, and rotates 90° between the open and closed positions. The cylinder is sized for 60 psi or 80 psi (415 kPa or 550 kPa), and is limited to 100 psi (690 kPa) maximum.

Lubrication

The R3 PowerRac Cylinder Actuator is lubricated at the factory, and does not require routine maintenance lubrication. If the actuator is disassembled, lubrication is required as described in the *Actuator Reassembly* section.

Open and Closed Position Stops

The adjustable open and closed position stops prevent the actuator from rotating beyond the open and closed positions of the valve. If the actuator is factory-mounted on the valve, the stops are preset, and do not require further adjustment. If the actuator is not factory-mounted on the valve, or if the actuator is removed and/or disassembled, the stops will require adjustment as described below. Refer to the Valve Instructions for closed-position information, and adjust the stop screws after the actuator is mounted on the valve.

The adjustable stop screws are secured with jam nuts, and are located in the extreme ends of the actuator as shown in Figures 1 and 2. The closed position stop is located in the cylinder cap, and the open position stop is located in the end cover. To adjust either stop screw, loosen the jam nut and turn the screw counterclockwise to increase the stroke, or clockwise to decrease the stroke. After the stop is adjusted to the desired position, hold the screw from turning, and tighten the jam nut.

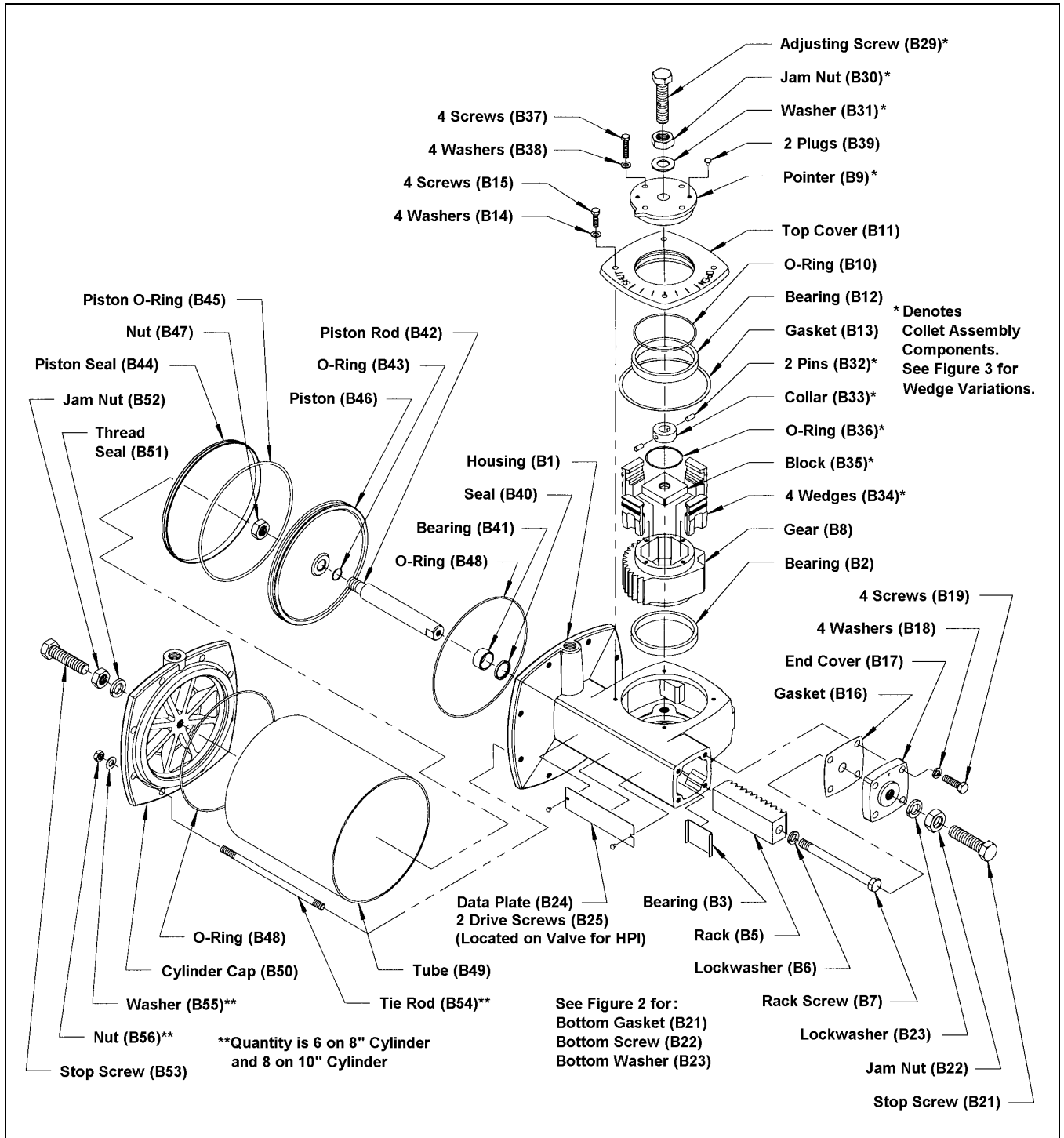

Figure 1 - Component Identification, Unassembled

DeZURIK

R3 PowerRac™ Cylinder Actuator

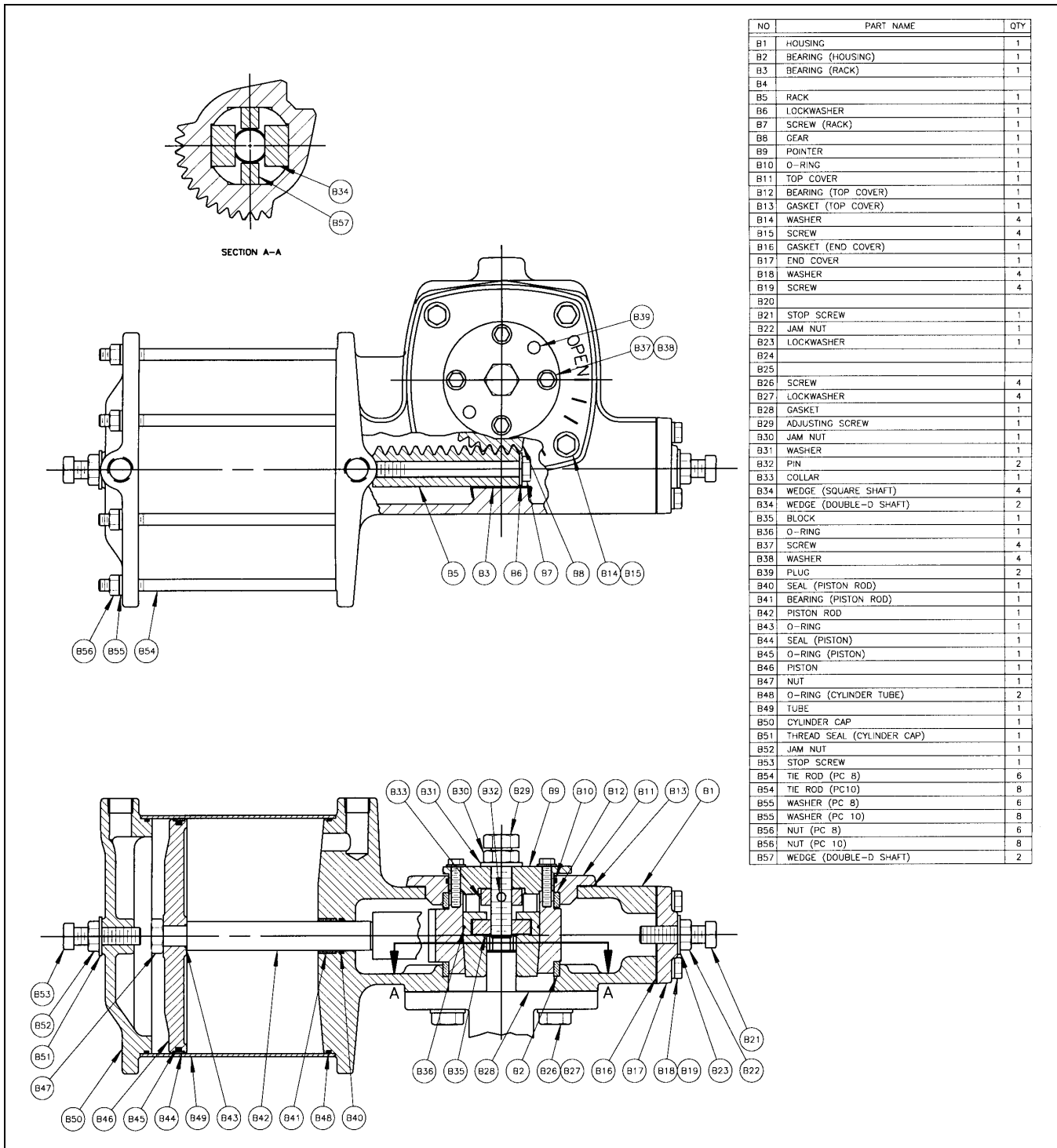

Figure 2 - Component Identification, Assembled

Open and Closed Position Stops *(Continued)*

- With an 8" (200 mm) cylinder, tighten the closed position stop nut (3/4") to 140 ± 18 foot pounds (190 ± 24 Nm); tighten the open position stop nut (7/8") to 230 ± 30 foot pounds (312 ± 41 Nm).
- With a 10" (250 mm) cylinder, tighten both stop nuts (7/8") to 230 ± 30 foot pounds (312 ± 41 Nm).

Removing Actuator From Valve

Refer to Figures 1 and 2 for component identification.

1. Shut down the flow in the pipeline.



WARNING!

Flow in the pipeline with the actuator removed can allow the valve to slam closed and cause personal injury and/or damage to the flow system. Shut down the flow in the pipeline before removing the actuator from the valve.

2. Disconnect and lock out the pneumatic power to the actuator to prevent accidental operation of the actuator.



WARNING!

Moving parts from unexpected operation of a powered actuator can cause personal injury or equipment damage. Disconnect and lock out power to the actuator before servicing.

3. Disengage the actuator from the valve shaft by loosening the jam nut (B30) *clockwise* and loosening the adjusting screw (B29) *counterclockwise*.
4. Remove the four mounting screws (B26) that fasten the actuator to the valve.
5. Remove the actuator from the valve by lifting the actuator from the valve shaft.

Actuator Disassembly

Refer to Figures 1 and 2 for component identification.

1. Remove the four pointer screws (B37) and washers (B38); remove the pointer (B9), together with the other collet assembly components indicated in Figure 1.
2. Remove the four top cover screws (B15) and washers (B14), and remove the top cover (B11).
3. Remove the top cover gasket (B13) and the O-Ring (B10).
4. Remove the gear (B8).
5. Remove the four end cover screws (B19) and washers (B18), and remove the end cover (B17) and gasket (B16).
6. Remove the rack screw (B7) and lockwasher (B6), and separate the rack (B5) from the piston rod (B42).
7. Remove the rack bearing (B3).

Actuator Disassembly (Continued)

1. Remove the tie rod nuts (B56) and washers (B55) from the tie rods (B54), and remove the cylinder cap (B50).
2. Remove the piston rod (B42)— with piston (B46) and cylinder tube (B49)— from the cylinder head on the housing (B1).
3. Remove the piston rod (B42) and piston (B46) from the cylinder Tube (B49).
4. Remove the piston nut (B47), the piston (B46), and the O-ring (B43) from the piston rod (B42).
5. Remove the piston seal (B44) and the O-ring (B45) from the piston (B46).
6. Remove the piston rod seal (B40) from the actuator housing (B1).
7. Remove the two cylinder tube O-rings (B48) from the cylinder head on the housing (B1) and from the cylinder cap (B50).
8. Remove the tie rods (B54) from the actuator housing (B1).

Actuator Reassembly

Steps 1 through 7 apply to reassembly of the cylinder components. Clean and inspect all parts before reassembly. Worn parts, especially sealing components such as O-rings and other seals should be replaced. Lubricate the cylinder O-rings, other seals, and cylinder tube walls with a paint-like coating using one of these lubricants:

- Dow Corning Molykote No. 44 (**recommended**)
- Shell Retinax AM (alternate)
- Shell Lithall MDS (alternate)

Refer to Figures 1 and 2 for component identification.

1. With the O-ring groove toward the piston rod, place the O-ring (B43), the piston (B46), and the nut (B47) on the piston rod (B42). Tighten the nut to 120 ± 10 foot pounds (163 ± 14 Nm).
2. Place the O-ring (B45) in the smaller groove of the piston (B46). Place the piston seal (B44) in the larger groove of the piston as far around the circumference as possible without stretching the seal. Angle the remaining.
3. Place one cylinder tube O-ring (B48) in the groove in the cylinder head on the housing (B1), and place the other O-ring in the groove in the cylinder cap (B50).
4. Place the 3-piece piston rod seal (B40) in the cylinder head of the housing (B1). Place the rubber seal in position first, and then place a wiper ring in position on each side of the seal.
5. Place the cylinder tube (B49) over the piston (B46) at about a 45° angle. Carefully square the piston into alignment with the cylinder tube, and push the cylinder tube and piston rod into position on the cylinder head of the housing (B1). Use care to prevent damage to the seals. Push the piston (B46) into the cylinder so that the piston is against the cylinder head.
6. Apply Loctite Primer N and Loctite Stud Lock to the shorter threads on each of the tie rods (B54), and turn each stud as far as it will go into the housing (B1).
7. Align the holes in the cylinder cap (B50) with the tie rods (B54) and insert the cylinder cap into the cylinder tube (B49). Place the tie rod nuts (B56) and washers (B55) on the tie rods. Tighten the nuts to 16 ± 2 foot pounds (22 ± 3 Nm).

Actuator Reassembly (Continued)

Steps 8 through 18 apply to reassembly of the housing components. Clean and inspect all parts before reassembly. Worn parts, especially sealing components such as O-rings, other seals, and gaskets should be replaced. Before housing reassembly, apply a paint-like coating using one of these lubricants:

- Keystone Zeniplex-1 (**recommended**)
- Amoco Amolith Grease #1-EP (alternate)
- Amsoil GHD (alternate)
- Mobil Mobilux EP 1 (alternate)
- Shell Alvania EP 1 (alternate)
- Texaco Multifak EP 1 (alternate)

to the following surfaces:

- The fabric side of the rack bearing (B3) and the mating side of the rack (B5)
 - Both bearing hubs of the gear (B8)
 - The top cover O-ring (B10) and the groove in the top cover (B11)
 - Both sides of the four wedges, and the mating surfaces inside of the gear (B8)
 - The teeth in the rack (B5) and in the gear (B8)
8. Place the rack bearing (B3) in position in the housing (B1). A dab of grease on the back side of the rack bearing will help to hold it in place.
 9. Note the witness mark on the tooth near one end of the rack (B5). Assemble the end of the rack opposite the witness mark to the end of the piston rod (B42) with the rack screw (B7) and lockwasher (B6). Do not tighten the screw until step 14 below.
 10. With the four tapped holes facing upwards, place the gear (B8) into the housing bearing (B2) so that the marked tooth on the rack (B5) meshes between the two marked teeth on the gear as shown in Figure 3.
 11. Place the O-ring (B10) in the groove of the top cover (B11).
 12. Mount the top cover (B11) and gasket (B13) to the housing (B1) with the four screws (B15) and washers (B14). Tighten the screws to 15 ± 2 foot pounds (20 ± 3 Nm).
 13. Place the actuator in the open position— with the piston rod (B42) extended into the housing— before the next step.
 14. Tighten the rack screw (B7) to 180 ± 20 foot pounds (244 ± 27 Nm). If necessary, apply 80 psi (550 kPa) air pressure to the cap end of the cylinder to prevent the piston rod from rotating.
 15. Turn the jam nut (B22) and the lockwasher (B23) onto the stop screw (B21), and turn the stop screw into the center hole in the end cover (B17) until the end of the stop screw protrudes about 1/4" (6 mm) through the end cover. Turn the jam nut finger tight.
 16. Mount the end cover (B17)— with the 'T' mark towards the top— and the gasket (B16) to the housing (B1) with the four screws (B19) and washers (B18). Tighten the screws to 38 ± 5 foot pounds (52 ± 7 Nm).
 17. Turn the adjusting screw (B29) so that the four wedges (B34) are about 1/32" (0.8 mm) from the bottom of the pointer (B9).
 18. With the actuator in the open or closed position, place the collet assembly components into the opening in the gear (B8), and align the pointer (B9) with the corresponding position on the top cover (B11). Mount the pointer to the gear with the four screws (B37) and washers (B38). Tighten the screws to 15 ± 2 foot pounds (20 ± 3 Nm).

DeZURIK

R3 PowerRac™ Cylinder Actuator

Table A : Wedge Identification Numbers for Double-D Valve Shafts in Figure 3

Dimension Across Shaft Flat, Nominal		Shaft Diameter, Nominal		Wedge Identification Number	
inches	mm	inches	mm	For Two Wedges (B34) on Shaft Flats	For Two Wedges (B34) on Shaft Diameter
0.944	24.00	1.120	28.45	2	1
1.259	32.00	37.97	37.97	4	3

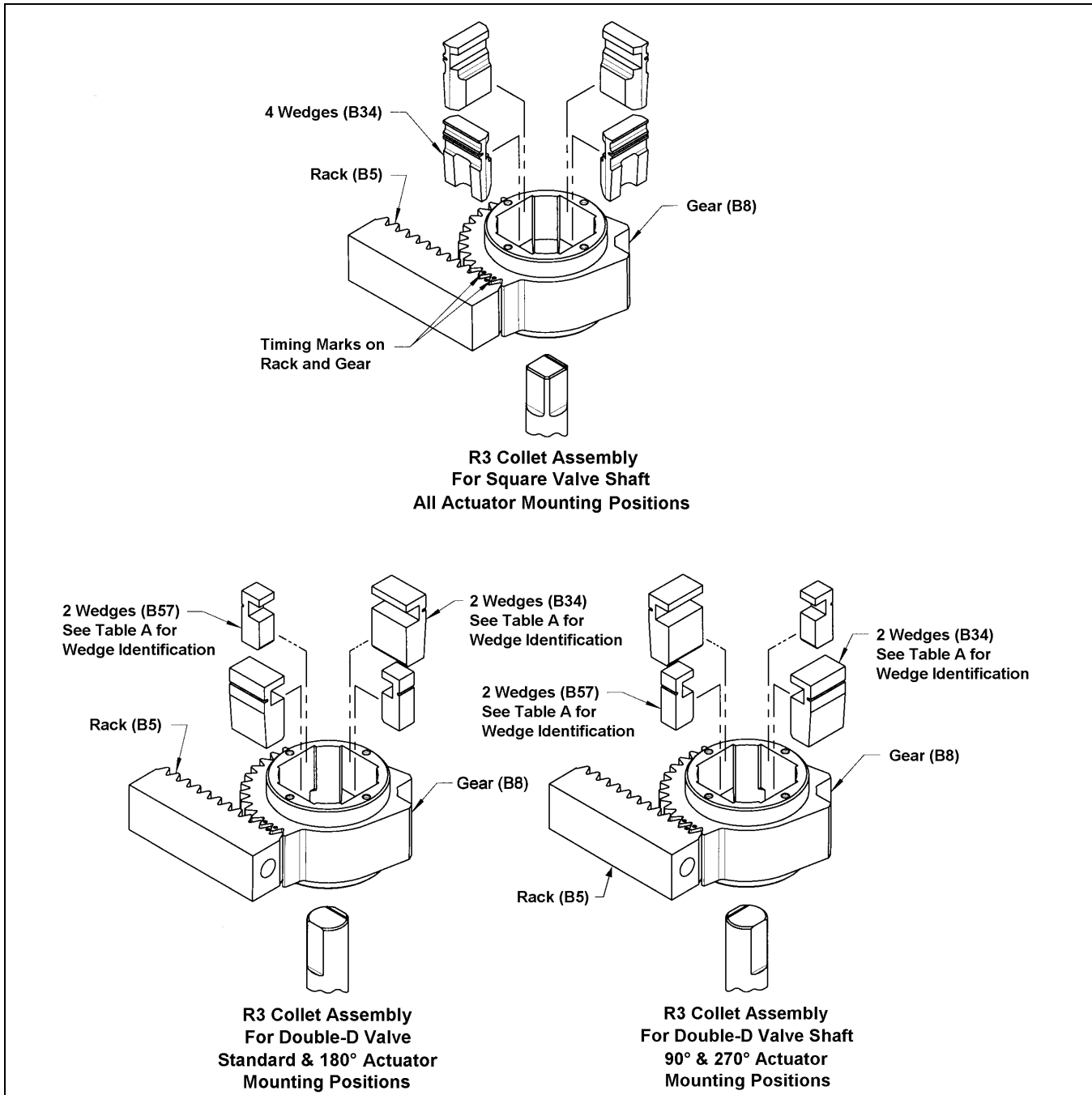

Figure 3 – Collet Assembly and Gear Information

Mounting Actuator on Valve

Refer to Figures 1 and 2 for component identification.

1. Select one of the available actuator-to-valve mounting positions shown on the Installation Drawing. Match the open or closed position of the valve with the open or closed position of the actuator. Also, note the position of the word “open” on the top cover (B11). The cover must be positioned on the housing (B1) so that dial hash mark for “open” will be parallel with the pipeline when the valve is installed. One or more of the following four steps may be required, depending upon the positions of the valve, the actuator, the actuator cover, and the mounting position selected.
 - a. Rotate the valve shaft, and/or
 - b. Stroke the actuator, and/or
 - c. Select a different actuator-to-valve mounting position, and/or
 - d. Remove and re-index the cover. If this step is necessary, remove the four cover screws (B15), rotate the cover, and replace the four cover screws (B15) and washers (B14). Tighten the screws to 15 ± 2 foot pounds (20 ± 3 Nm).

Note: If the valve has a double-D shaft connection, the actuator may be mounted 180° from the original position with existing components. The actuator may be mounted 90° or 270° from the original position with a new alternative gear (B8). To change to the other configuration, obtain the new gear, remove the cover screws (B15), the cover (B11), and the gear (B8). Then assemble the new gear, rearrange the collet wedges as shown in Figure 3, and replace the cover as described in steps 10 and 12 of the *Actuator Reassembly* section.

2. If the actuator does not include the collet assembly (the components are identified in Figure 1, grease the components as described in the *Actuator Reassembly* section and install the assembly as explained in steps 17 and 18 in the same section.
3. Certain high-temperature valves include and require a high-temperature gasket (B28). If the valve includes a gasket, use the gasket included with the valve rather than the gasket included with the actuator. Place the gasket between the actuator and the valve; engage the actuator with the valve shaft in the desired mounting position as determined in step 1, and slide the actuator onto the valve shaft.
4. Assemble the four actuator mounting screws (B26) with lockwashers (B27) up through the mounting holes in the top of the valve (or the actuator adaptor on the valve), through the gasket (B28), and into the threaded holes in the bottom of the actuator. Tighten the screws finger tight— so that the valve and actuator mounting surfaces are in contact, but are free to slide and self-center during the next step.
5. Tighten the adjusting screw (B9A) to 200 ± 30 foot pounds (271 ± 41 Nm).
6. Tighten the actuator mounting screws (B26) to 300 ± 40 foot pounds (407 ± 53 Nm).
7. Loosen the adjusting screw (B9A).
8. Re-tighten the mounting screws (B26) to 300 ± 40 foot pounds (407 ± 53 Nm).
9. Tap the adjusting screw with a rubber mallet so that the gear (B8) bottoms out against the lower housing bearing (B2).

Mounting Actuator on Valve *(Continued)*

10. Begin to tighten the adjusting screw (B9A); as the adjusting screw becomes snug, repeat step 9, and finish tightening to 200 ± 30 foot pounds (271 ± 41 Nm).
11. Tighten the jam nut (B30) *counterclockwise* to 200 ± 30 foot pounds (271 ± 41 Nm).
12. Adjust the open and closed position stops as explained in the *Open and Closed Position Stops* section.
13. Operate the actuator and valve three full cycles to demonstrate that the unit operates smoothly in both directions. Do not exceed 100 psi (690 kPa) in the cylinder.

Changing Mounting Position of Actuator on Valve

The actuator may be mounted on the valve in any one of the mounting positions shown on the Installation Drawing. The mounting position may be changed as follows:

1. Remove the actuator from the valve as described in the *Removing Actuator From Valve* section.
2. Replace the actuator on the valve as described in the *Mounting Actuator On Valve* section.

Lockable Model

The R3 PowerRac Cylinder Actuator is available as a lockable model that allows the actuator to be locked in either the open or closed position. The lockable model is identified by PRL in the catalog characteristic.

As shown in Figure 4, the lockable model includes two lock screws (B64) and two jam nuts (B65). In the locked position, the screws engage with mating notches in the gear (B8). A lockout cover assembly (B60) is also included.



CAUTION!

The two lock screws (B64) must be in either the unlocked or the locked position as described in the following sections. The gear (B8) will be damaged if either of the stop screws is placed in an intermediate position between the unlocked and locked positions.

Unlocked Condition

Under normal unlocked running conditions, both of the lock screws are backed out of the housing to allow the gear to rotate freely in either direction. To be fully disengaged, the distance from the housing to the end of each lock screw must be at least 3 1/8" (80 mm). To hold the lock screws in position, the jam nuts are tightened to 140 ± 18 foot pounds (190 ± 24 Nm).

Lockable Model (Continued)

Locked: Closed Position

Follow the steps below to change the unit from the unlocked condition to the locked closed position. Refer to Figure 3 for component identification. Before proceeding, the open and closed position stops must be correctly adjusted as described in the *Open and Closed Stops* section.

1. Operate the actuator to the fully closed (clockwise) position.



WARNING!

Adjust only the left-side lock screw to lock the actuator in the closed position. Adjusting the wrong screw does not lock the actuator, and can result in personal injury or equipment damage.

2. Loosen the jam nut (B65) on the **left** side lock screw (B64), as viewed when facing the top of the heads of the lock screws. Hold the lock screw from turning, and turn the jam nut several turns counterclockwise, to the head of the lock screw.
3. Turn the **left** side lock screw clockwise several turns until resistance is felt from the lock screw contacting the notch in the gear (B8). Tighten the lock screw to 5 to 10 foot pounds (7 to 14 Nm) to assure that the lock screw is contacting the gear.
4. Turn the **left** side jam nut clockwise against the actuator housing. While holding the lock screw from turning, tighten the jam nut to 140 ± 18 foot pounds (190 ± 24 Nm).
5. Place and lock the lockout cover assembly (B60) on the head of the **left** side lock screw.

Locked: Open Position

Follow the steps below to change the unit from the unlocked condition to the locked open position. Refer to Figure 4 for component identification. Before proceeding, the open and closed position stops must be correctly adjusted as described in the *Open and Closed Stops* section.

1. Operate the actuator to the fully open (counterclockwise) position.



WARNING!

Adjust only the right-side lock screw to lock the actuator in the open position. Adjusting the wrong screw does not lock the actuator, and can result in personal injury or equipment damage.

2. Loosen the jam nut (B65) on the **right** side lock screw (B64), as viewed when facing the top of the heads of the lock screws. Hold the lock screw from turning, and turn the jam nut several turns counterclockwise, to the head of the lock screw.
3. Turn the **right** side lock screw clockwise several turns until resistance is felt from the lock screw contacting the notch in the gear (B8). Tighten the lock screw to 5 to 10 foot pounds (7 to 14 Nm) to assure that the lock screw is contacting the gear.
4. Turn the **right** side jam nut clockwise against the actuator housing. While holding the lock screw from turning, tighten the jam nut to 140 ± 18 foot pounds (190 ± 24 Nm).
5. Place and lock the lockout cover assembly (B60) on the head of the **right** side lock screw.

Lockable Model (Continued)

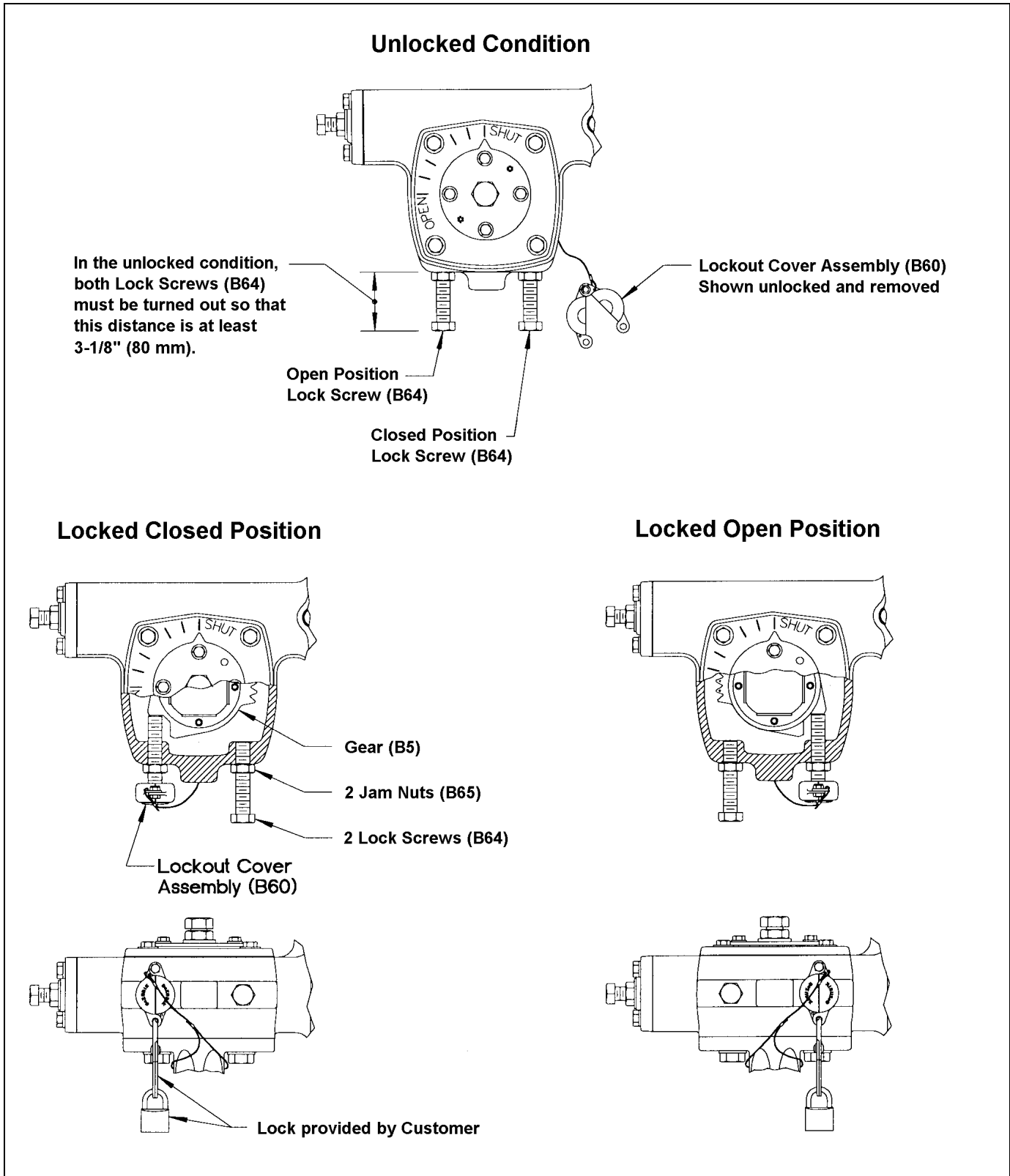

Figure 4 – Lockable Model, Component Identification

Troubleshooting

Condition	Possible Cause	Corrective Action
Actuator closes to wrong position	Closed position stop is set incorrectly	Adjust closed position stop. See OPEN AND CLOSED STOPS.
Actuator opens to wrong position	Open position stop is set incorrectly	Adjust open position stop. See OPEN AND CLOSED STOPS.
Actuator will not fully operate valve	Cylinder pressure is low	Increase cylinder pressure. Do not exceed 100 psi (69 kPa).
	Actuator is sized incorrectly	Use larger actuator
	Piston seal in cylinder is leaking	Replace piston seal(s). See ACTUATOR DISASSEMBLY AND REASSEMBLY.
	Pipeline obstruction in valve is preventing closure	Remove obstruction
	Lockable Model is locked.	Place in unlocked condition. See LOCKABLE MODEL.
Actuator rotates wrong direction	Air connections to cylinder are incorrect	Reverse air connections to cylinder