



APCO COMBINATION AIR VALVES

Series 1800
Custom Combination
Duplex Body



Series 140C
Standard Combination
Single Body

APCO Combination Air Valves

Single Body Double Orifice

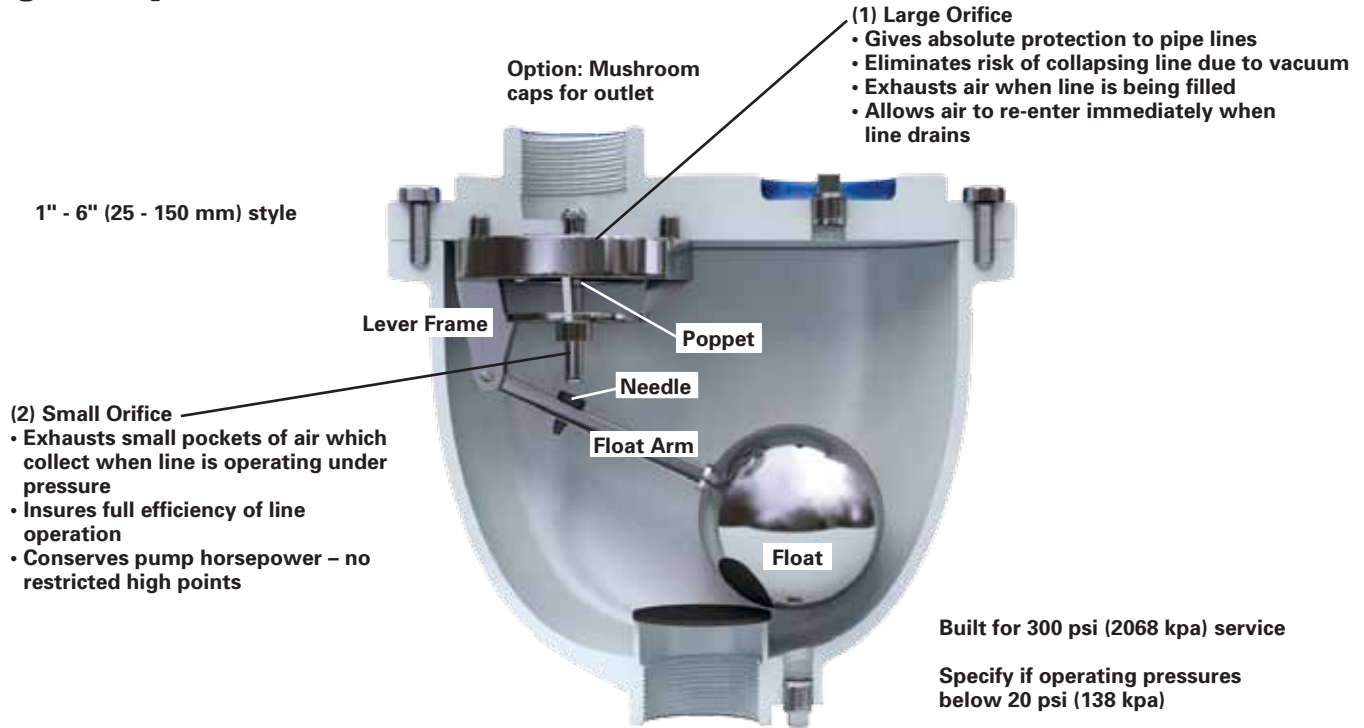

Materials Used in Both Style Combination Air Valves

Body, Cover, 1" - 4" (25 - 100 mm)	Ductile iron
Body, Cover, 6" - 8" (150 - 200 mm)	Cast iron
Float.....	Stainless steel
Seat	Buna-N
Lever Frame 1" - 4" size (25 - 100 mm).....	Delrin
Lever Frame 6" - 8" size (150 - 200 mm)...	Cast iron
All other internal parts	stainless steel or bronze

Bronze components meet current lead-free requirements.

Manufactured to AWWA C-512

ISO flange connections available

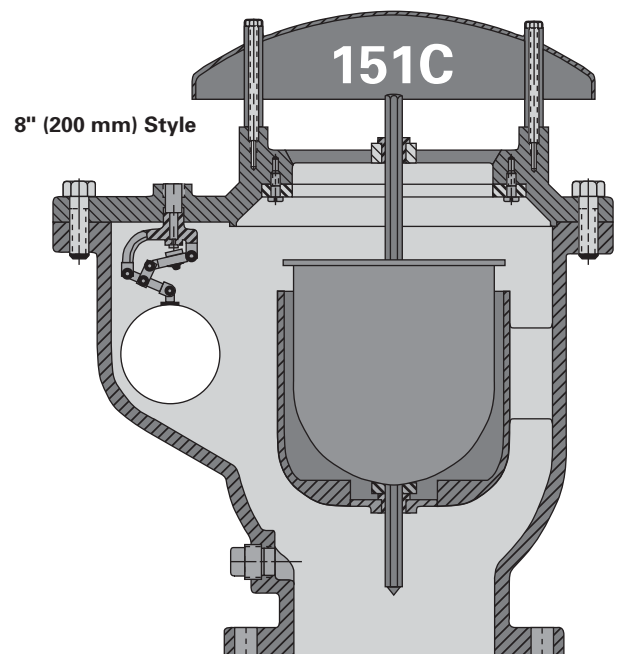

Sizing

1" (25 mm) 143C

Photo on previous page*

Physical Dimensions

Height - 10" (254 mm)
Width - 7" (178 mm)
Length - 11" (279 mm)
Weight - 35 lbs. (16 kg)

Inlet/Outlet

1" (25 mm) pipe thread

* Except poppet

125 & 250 lb. flanges
also available

2" (50 mm) 145C

Photo on previous page

Physical Dimensions

Height - 12.25" (311 mm)
Width - 8" (203 mm)
Length - 14" (356 mm)
Weight - 75 lbs. (34 kg)

Inlet/Outlet

2" (50 mm) pipe thread

125 & 250 lb. flanges
also available

3" (80 mm) 147C

Photo on previous page

Physical Dimensions

Height - 15.5" (394 mm)
Width - 10" (254 mm)
Length - 16" (406 mm)
Weight - 100 lbs. (45 kg)

Inlet/Outlet

3" (80 mm) pipe thread

125 & 250 lb. flanges
also available
Height flanged 16.5" (419 mm)

4" (100 mm) 149C

Photo on previous page

Physical Dimensions

Height - 17.125" (435 mm)
Width - 11" (279 mm)
Length - 18" (457 mm)
Weight - 170 lbs. (77 kg)

Inlet/Outlet

4" (100 mm) pipe thread

125 & 250 lb. flanges
also available
Height flanged 19" (483 mm)

6" (150 mm) 150C

Photo on previous page

Physical Dimensions

Height - 27.25" (692 mm)
Width - 13" (330 mm)
Length - 18.375" (467 mm)
Weight - 205 lbs. (93 kg)

Inlet

125 & 250 lb. flange

Outlet options

- Plain with hood
- Threaded
- Flanged

8" (200 mm) 151C

Drawing on previous page

Physical Dimensions

Height - 25.75" (654 mm)
Width - 17.5" (445 mm)
Length - 22.25" (565 mm)
Weight - 300 lbs. (136 kg)

Inlet

125 & 250 lb. flange

Outlet options

- Plain with hood
(as shown)
- Flanged

To size air valves for pipeline service use APCO Air Valve Computer or Apslide computer software

Single Body Specifications

Combination Air Valve sizes 1" (25 mm) through 8" (200 mm), (single body, double orifice) allows large volumes of air to escape out the large orifice when filling a pipeline and closes when liquid enters the valve. When the valve is closed and pressurized, the small air release orifice will open to allow small pockets of air to escape automatically and independently of the large orifice.

The large orifice shall also allow large volumes of air to enter during pipeline drainage to break the vacuum. The body inlet must be baffled to protect the float from direct forces of rushing air and water to prevent premature valve shut-off.

The Buna-N seat must be fastened to the valve cover without distortion for drop tight shut-off. The floats shall be heavy stainless steel. The plug or float shall be center guided through hex bushings for positive shut-off.

Valve exterior to be painted with universal metal primer paint.

All materials of construction shall be certified in writing to conform to ASTM specifications as follows:

Body & Cover 1" - 4" (25 - 100 mm)	Ductile Iron	ASTM A536 GR 65-45-12
Body & Cover 6" - 8" (150 - 200 mm)	Cast Iron	ASTM A126 GR.B
Float	Stainless Steel	ASTM A240
Needle & seat	Buna-N	
Plug	Stainless Steel	ASTM A276
Leverage frame	Delrin/Cast Iron	ASTM D4181/ASTM A126 GR.B

*Bronze components meet current lead-free requirements.

There Are Basically Two Types of Air Valves:

See Orifice Size Chart (next page)

Type 1: Air/Vacuum Valves with (1) large orifice to vent large volumes of air for efficient filling and draining of pipelines. This protects against vacuum and water column separation or pipeline collapse.

Type 2: Air Release Valves with (2) small orifice for continuous venting of air pockets as they accumulate in a pressurized pipeline.

When the above types are combined, the result is a combination air valve.

The Combination Air Valve is available in a single body double orifice shown on page 2, or in a duplex body arrangement (see page 6).

The single body is most popular due to its smaller overall size and resulting space saving inside a valve vault. It is available in 1" (25 mm) to 8" (200 mm) sizes.

How it Works

Sizes 1" (25 mm) through 6" (150 mm) incorporate a poppet (or plug) which rests freely inside the lever frame. The center stem of the poppet has a small orifice through it. When water enters the main valve body it raises the float and float arm which puts the needle, attached to the arm, in contact with the poppet stem while lifting the poppet to the shut-off position against the large orifice.

As air accumulates inside the main valve body the water is displaced. The float arm falls away from the poppet stem to expose the small orifice and the pocket of air is vented. Water re-enters the main valve body lifting the float arm back to the shut-off position and the cycle repeats as air accumulates. As long as the main valve body is under pressure, the poppet stays closed because the pressure differential across the large orifice is more than the poppet can overcome.

If, however, a negative pressure occurs inside the main valve body, the poppet will drop open to allow air in and prevent a vacuum from forming in the pipeline.

Size 8" (200 mm) functions in the same manner, but, instead of a poppet, a float is used for shutting off the large orifice and a separate internal float operated lever mechanism is incorporated with a small orifice for venting smaller pockets of air when the system is pressurized.

Every Combination Air Valve is hydrostatically seat and shell tested before it leaves our factory to insure quality performance in the field.

Where to Install

Typical pipeline showing its hydraulic gradient & the position of necessary APCO air valves

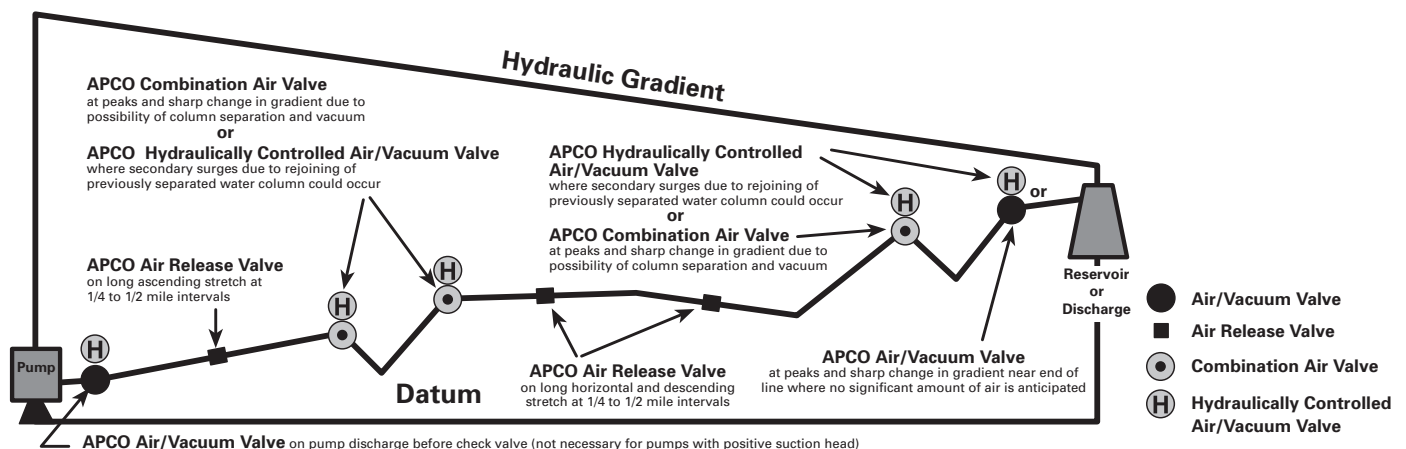

Note: Installing manways at intervals in larger size pipelines provides an excellent point to install air valves

Note: Please specify if pressure is below 20 psi

Discharge Capacities For Combination Air Valve

Curves shown are actual flow capacities at 14.7 psi barometric pressure and 70° F temperature based on actual test. These figures are not only the flow capacities across the orifice but flow across the entire valve. In the test set-up, approach velocity to the valve is negligible therefore actual capacity exceeds the values shown on chart.

Test conducted by: Phillips Petroleum Company Engineering Department - Test Division Edmond Plant

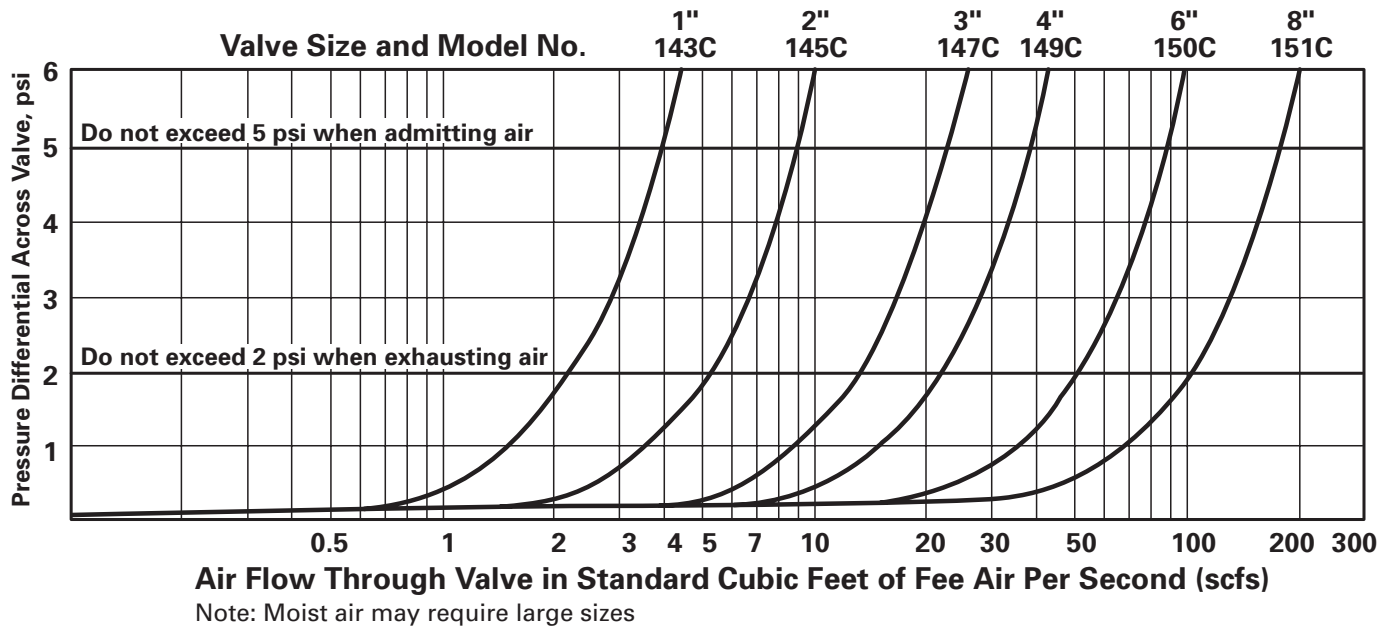

Note: Moist air may require large sizes

Orifice Sizes For 300 psi (3068 kpa) Working Pressure		
Model	(1) Large Orifice	(2) Small Orifice
143C	$\frac{1"}{25}$	$\frac{.078}{2}$
145C	$\frac{2"}{50}$	$\frac{.094}{2}$
147C	$\frac{3"}{80}$	$\frac{.094}{2}$
149C	$\frac{4"}{100}$	$\frac{.094}{2}$
150C	$\frac{5"}{125}$	$\frac{.125}{3}$
151C	$\frac{6"}{150}$	$\frac{.156}{4}$

Inch
Millimeter

Custom Combination Air Valves

Each Custom Combination Air Valve consists of one APCO Air/Vacuum Valve, one APCO Air Release Valve and an optional one DeZURIK Butterfly Valve, shipped completely piped and assembled. Price of each Custom Combination Air Valve includes 1" (25 mm) piping and 1" (25 mm) gate or ball valve.

Available in 125, 250, 600 and 900 psi (862, 1724, 4137, 6205 kpa) classes for those special jobs where you want the very best.

Custom Combination Air Valves are recommended where operating pressures exceed 300 psi (2068 kpa) or size requirements exceed 4" (100 mm).

Sizing

To determine the correct size Single Body or Duplex Body Combination Air Valves to use on each high point of the pipeline, refer to Bulletin 610, use the APCO Air Valve Computer (available on request) or you may send a copy of your pipeline profile to our engineering department.

Another feature to recommend the use of Custom Combination Air Valves is the side mounted Air Release Valve which can be any of four valves as shown in the chart on the next page. With the addition of the Air Release Valve the orifice is much larger and hence the venting capacity much greater than the orifices in the single body Combination Air Valve. This is important where large volumes of air are anticipated after the pipeline is filled and operating.

Series 1800

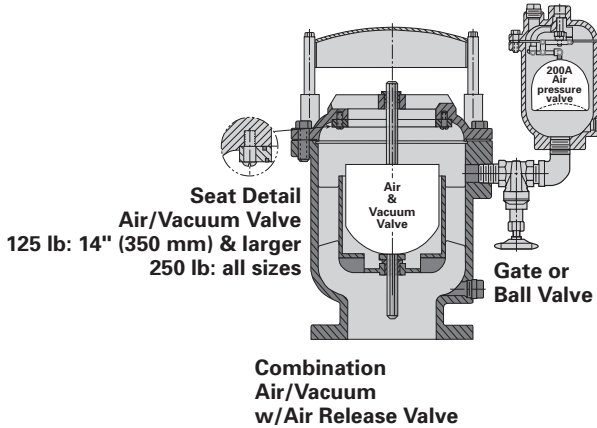

Combination Air/Vacuum w/Air Release Valve

Series 1100A

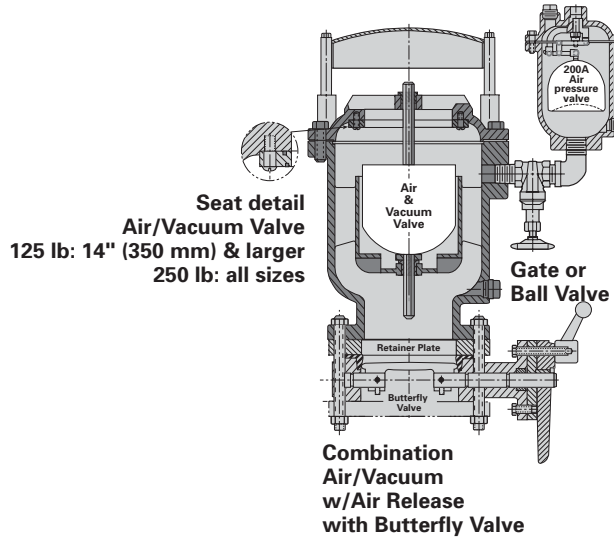

Combination Air/Vacuum w/Air Release with Butterfly Valve

Series 1800				
Size	Model	Width	Height	
			125#	250#
			.188"/5mm Orifice	.156"/4mm Orifice
4" 100	1804	19.5" 495	20.25" 514	20.625" 524
6" 150	1806	22.75" 578	22.75" 578	23.125" 587
8" 200	1808	25.5" 648	24.75" 629	25.25" 641
10" 250	1810	27.875" 708	26.75" 679	27.375" 695
12" 300	1812	32.875" 835	31.375" 797	31.375" 797
14" 350	1814	41.875" 1064	30.75" 781	30.75" 781
16" 400	1816	45.5" 1156	32" 813	32" 813
18" 450	1818	42" 1067	34" 864	34" 864
20" 500	1820	46" 1168	40" 1016	40" 1016
24" 600	1824	53" 1346	48" 1219	48" 1219

Inch
Millimeter

Series 1100A				
Size	Model	Width	Height	
			125#	250#
			.188"/5mm Orifice	.156"/4mm Orifice
4" 100	1104A	19.5" 495	23.5" 597	25" 635
6" 150	1106A	22.75" 578	27.25" 692	27.25" 692
8" 200	1108A	25.5" 648	31" 787	31.5" 800
10" 250	1110A	27.875" 708	33.5" 851	34" 864
12" 300	1112A	32.875" 835	40.75" 1035	40.75" 1035
14" 350	1114A	41.875" 1064	39.5" 1003	39.5" 1003
16" 400	1116A	45.5" 1156	43.25" 1099	43.25" 1099

Inch
Millimeter

Table of Orifice Sizes														
Model	Size	Maximum orifice which can be used with following pressures (psi/kpa)												
		10 69	25 172	50 345	75 517	100 689	125 862	150 1034	200 1379	250 1724	300 2068	500 3447	800 5516	1500 10342
200A	$\frac{1"}{25}$	$\frac{.313"}{8}$	$\frac{.313"}{8}$	$\frac{.313"}{8}$	$\frac{.25"}{6}$	$\frac{.188"}{5}$	$\frac{.188"}{5}$	$\frac{.188"}{5}$	$\frac{.156"}{4}$	$\frac{.156"}{4}$	$\frac{.156"}{4}$	X	X	X
200	$\frac{2"}{50}$	$\frac{.5"}{13}$	$\frac{.5"}{13}$	$\frac{.5"}{13}$	$\frac{.5"}{13}$	$\frac{.375"}{10}$	$\frac{.375"}{10}$	$\frac{.375"}{10}$	$\frac{.219"}{6}$	$\frac{.219"}{6}$	$\frac{.219"}{6}$	X	X	X
205	$\frac{2"}{50}$	X	X	X	X	$\frac{.5"}{13}$	$\frac{.375"}{10}$	$\frac{.375"}{10}$	$\frac{.219"}{6}$	$\frac{.219"}{6}$	$\frac{.219"}{6}$	$\frac{.219"}{6}$	$\frac{.125"}{3}$	X
206	$\frac{2"}{50}$	X	X	X	X	X	X	X	X	X	X	X	X	$\frac{.094"}{2}$

Inch
Millimeter

Standard orifices are in gray

Duplex Body Specifications

The Custom Combination Air Valve Series 1800 shall be heavily designed cast iron body to allow large volumes of air to escape through the orifice when filling the pipeline and shall shut off water tight, when the water enters the valve. The Custom Combination Air Valve shall also permit large volumes of air to enter through the orifice when the pipeline is being drained to prevent vacuum from forming and water column separation. The valve shall consist of a body, cover, baffle, float and seat. The baffle will be an integral part of the body, designed to protect the float from direct contact of the rushing air and slugs of water to prevent premature shut-off. The seat shall be Buna-N fastened into the valve cover without distortion and be easily replaced. The float shall be stainless steel and be center guided at each end for positive seating.

The Air/Vacuum Valve shall have the outlet covered with either a steel protector hood or be threaded or flanged. (Engineer to select outlet.)

The Automatic Air Release Valve shall be designed to operate under pressure to allow entrapped air inside the pipeline to escape. The shut-off prevents water from escaping. The Air Release Valve will then stay closed until more air accumulates and the opening cycle will repeat automatically. The Air Release Valve float shall be heavy stainless steel.

When Series 1100A is specified, a DeZURIK Butterfly Valve, wafer style shall be supplied for isolation service. The Butterfly Valve shall be freely interchangeable without the need for special tools. The seat must be Buna-N, molded with a steel flanged ring inside for high strength and tight seating. The disc must pivot eccentrically to minimize operating torque. The shafts must be stainless steel and double sealed with O-rings to prevent leakage.

The Custom Combination Air Valve Series 1800 and Series 1100A shall be furnished completely assembled and pressure tested from the factory as a complete unit ready for installation on the pipeline.

All materials of construction shall be certified in writing to conform to ASTM specifications as follows:

Valve bodies	Cast Iron or Ductile Iron	ASTM A126 GR.B ASTM A536 GR. 65-45-12
Shafts	Stainless Steel	ASTM A270
Seats	Buna-N	
Floats	Stainless Steel	ASTM A240
Exterior primer	Universal Metal Primer	

*Bronze components meet current lead-free requirements.

Valve to be Series 1800 Custom Combination Air/Vacuum/Air Release Valve or Series 1100A Custom Combination Air/Vacuum/Air Release Valve with isolation Butterfly Valve.

Sales and Service

For information about our worldwide locations, approvals, certifications and local representative:

Web Site: www.dezurik.com E-Mail: info@dezurik.com



250 Riverside Ave. N. Sartell, Minnesota 56377 • Phone: 320-259-2000 • Fax: 320-259-2227

DeZURIK, Inc. reserves the right to incorporate our latest design and material changes without notice or obligation. Design features, materials of construction and dimensional data, as described in this bulletin, are provided for your information only and should not be relied upon unless confirmed in writing by DeZURIK, Inc. Certified drawings are available upon request.