

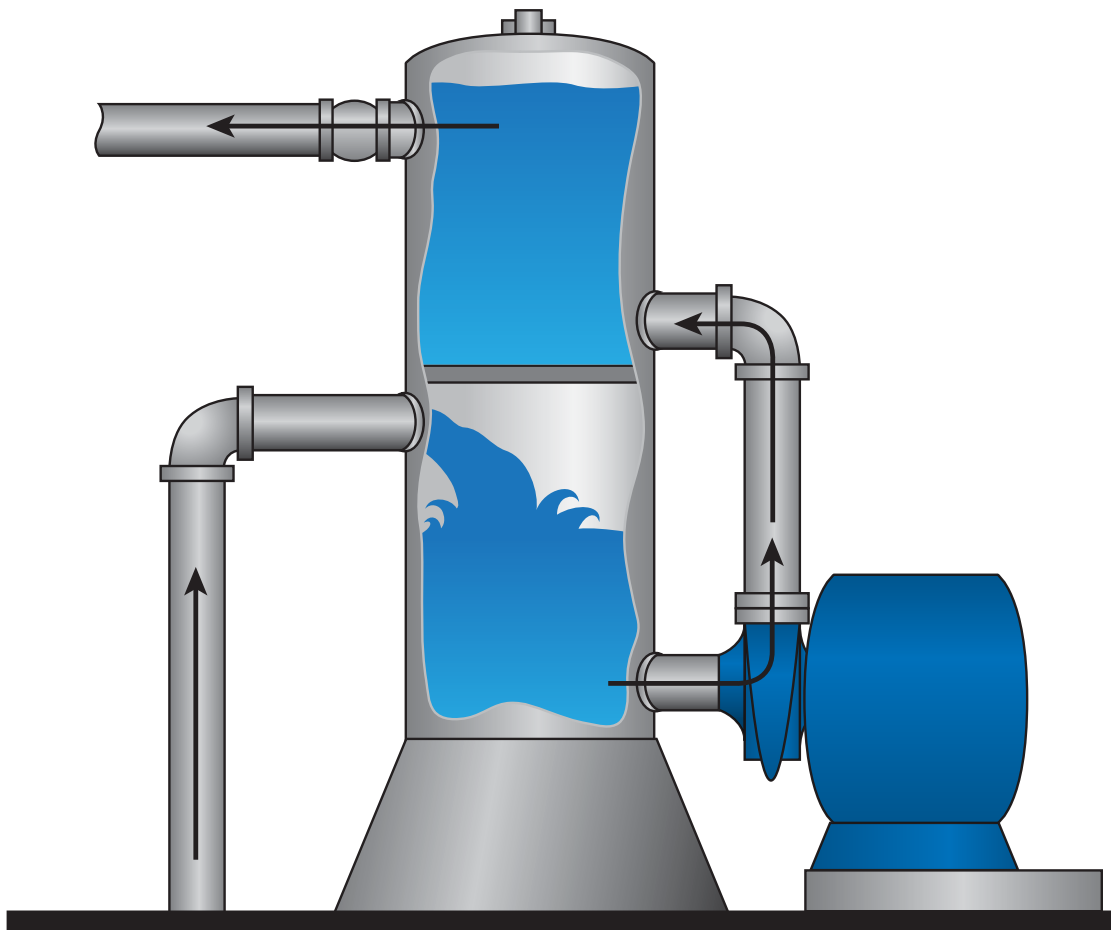

APCO AUTOMATIC PRIMERS



Automatic Primer

APCO Automatic Primers

APCO Automatic Pump Primers are used on suction lift, unsubmerged centrifugal pumps for water supply systems, sewage disposal, sump pumping, trench and irrigation work and unloading tanks and tank cars. They are especially valuable on intermittent pumping service.

What the APCO Automatic Primer Is

The APCO Primer is a simple tank and piping system without moving parts or anything to get out of order. Its operation is entirely automatic and requires no attention. It does not affect the characteristics of the pump, to which it is connected. It will operate on suction lines of any length, against any head and at any capacity.

How It Works

The APCO Primer automatically primes the pumps to which it is attached whenever the pump is shut down, thus automatically keeping the pump always ready to pick up its load. The diagrams on page 3 will give a clear idea of how simply and efficiently the APCO Primer works.

Advantages of the APCO Primer

1. The APCO Primer costs little to install and nothing to operate.
2. It is entirely automatic and dependable.
3. Use of APCO Primers permits using unsubmerged horizontal centrifugal pumps.
4. Use of the APCO Primer does not require the use of foot valves which so often give trouble in other types of installations.
5. The automatic operation of the APCO Primer permits remote pump control, very often desirable in sump pumping and in water supply systems for towns, estates, golf courses, paper mills, steel mills and similar applications.

For Liquids Other Than Clear Water

When the primer is used on thin sewage or water of high turbidity, please note in your inquiry or order the type of material to be handled. By doing so the openings in the primer can be properly placed for the most waste solids in the water to be carried into the pump suction. Due to the agitation of the water entering this lower section and the water entering the upper section of the primer, the water is kept in an agitated state so that most of the solids are carried through the discharge pipe. Any solids remaining in this upper section when the pump is shut down flow back through the pump to be carried out when the pump is restarted.

Cleanout openings are also provided in both sections of the primer near the bottom so that any collection of solids can be flushed out. These cleanout openings can be piped with valves adjacent to the primer so that flushing can be done with the shutting down of the primer. These valves and pipe connections are not furnished with the primer, as these openings are plugged.

For Corrosive Liquids

Primers can be made of special materials for handling acids and other corrosive liquids.

Rubber Lined Primers

All primers can be made for rubber or plastic lining at special prices.

Vacuum Break or Equalizer

The vacuum break shown in the illustration on page 3 is a pipe connecting the upper and lower sections of the primer to equalize pressure when the pump is shut down and the water is returning to the lower section of the primer. When operating with liquids other than clear water, this pipe must be kept clear and is installed with plug tees for cleaning.

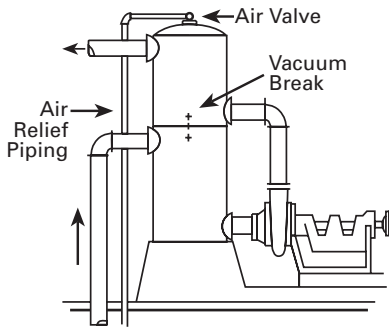

No. 1: When pumping dirty, greasy water, air relief piping may be used.

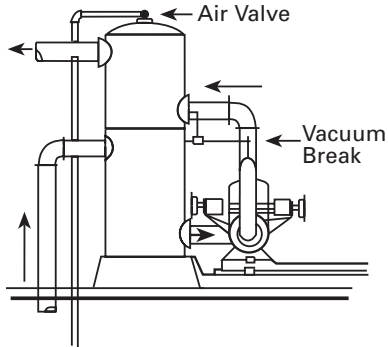

No. 2: Primer at end of double suction pump.

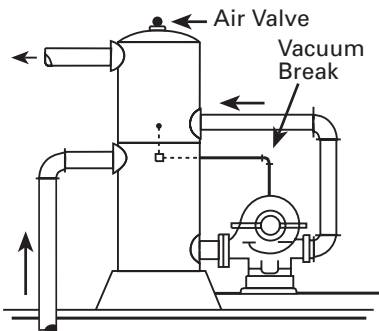

No. 3: Primer at side of double suction pump.

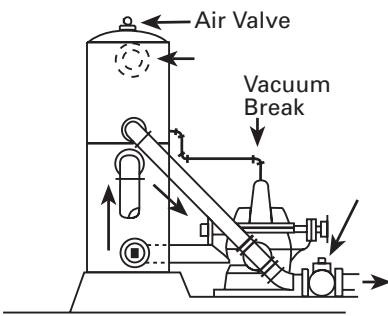

No. 4: When pumping at high pressure this arrangement may be used.

Hookups in diagrams #2, #3, and #4 show the vacuum break or equalizing pipe connected to the volute of the pump. This type of installation will tend to keep this vacuum break or equalizer free of sediment.

Air Valve

The illustrations show the air valve above the top of the primer. The air valve is screwed into the top of the primer and is entirely out of sight. There is a threaded opening for pipe connections to carry away any small amount of moisture that may be discharged through this valve. It is recommended that where sewage or water of high turbidity is handled that this pipe be omitted and a small pipeline be run from the opening in the top of the tank to the opening in the well or sump from which the water is being pumped. This is to prevent any clogging of this valve with solids.

Data Required for Proper Selection

Proper selection of primers requires the following information:

1. Diameter of suction pipe.
2. Capacity of the pump. Then, with the use of standard tables, the friction loss in the suction pipe and elbows can be determined
3. Vertical suction lift. Figure from the water level in the pit, well, or sump to the center line of the pump. The friction head loss in feet as determined in Item 2 must be added to this actual lift.
4. Total length of suction. Figure horizontal as well as vertical runs. The figures in the accompanying table give the maximum length of suction pipe that primers will handle at various lifts. These figures must not be exceeded.
5. Total head of discharge. This is required in order to determine the pressure for which the primer must be built.

Information on specific applications of APCO Primers will be promptly furnished upon submittal of data.

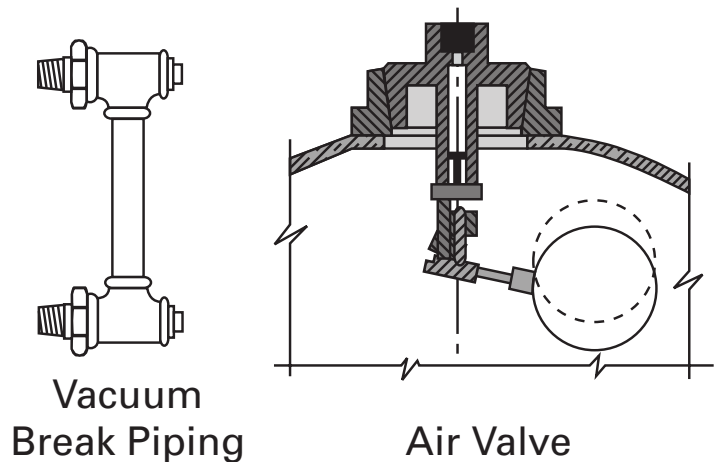

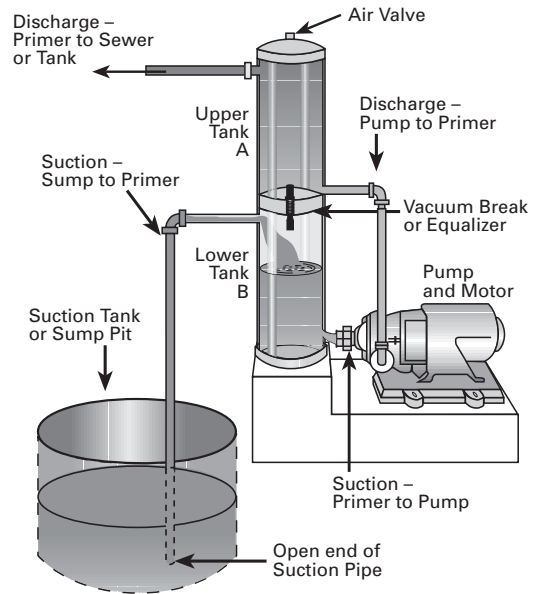
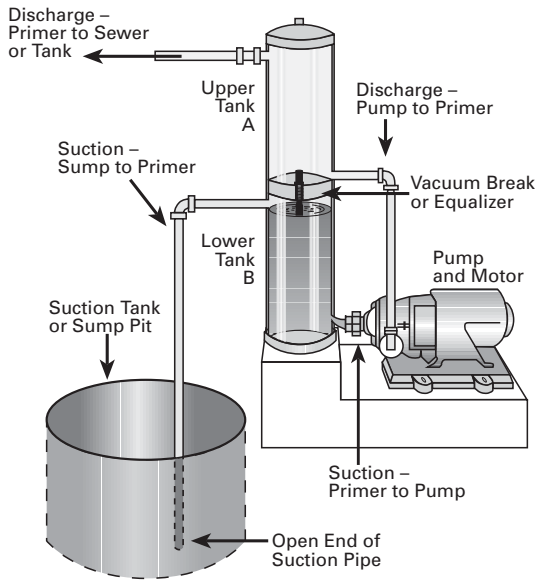

Phantom View of APCO Primer in Use with Pump Stopped

When the pump stops, the liquid in the upper chamber runs back into the pump and lower chamber of the primer, by gravity, thus refilling them with liquid and keeping the pump always ready for starting.

Phantom View of APCO Primer in Use with Pump Running

This illustration shows the APCO Primer in service with the pump running. When the pump starts, it draws liquid from the lower chamber and discharges it through the upper chamber. Withdrawal of liquid from the lower chamber creates a partial vacuum in this chamber which causes the liquid in the sump or well to rise in the suction pipe and flow through the primer to the pump.

Selection Data - Standard

Size	Dimensions, Inches	Size Pipe, Inches	Maximum Length of Suction Pipe Primers will Handle on These Lifts, Feet				Weight, lbs 50 psi pressure
			5'	10'	15'	20'	
0	8" x 36"	1	38	30	24	—	50
		1.5	15	12	—	—	50
1	10" x 40"	1	60	50	40	30	65
		1.5	30	25	20	—	65
		2	15	12	—	—	65
2	12" x 48"	1	115	95	75	54	100
		1.5	50	42	32	22	100
		2	35	24	16	—	100
		2.5	16	12	—	—	100
3	16" x 48"	1.5	115	95	75	50	160
		2	62	50	38	26	160
		2.5	40	32	23	—	160
		3	26	20	15	—	160
4	20" x 66"	2	130	110	90	65	280
		2.5	85	70	55	40	280
		3	60	48	35	24	280
		4	30	25	20	—	280
		5	18	14	—	—	340
5	24" x 72"	2.5	160	130	100	70	385
		3	115	94	70	45	385
		4	65	52	40	25	385
		5	40	32	22	—	445
		6	25	20	16	—	505
5A	30" x 72"	3	170	140	110	75	525
		4	100	80	60	40	525
		5	65	52	40	27	585
		6	43	34	25	—	645
6	30" x 96"	8	25	20	15	—	725
		4	128	100	77	56	760
		5	82	65	50	32	820
		6	56	44	36	22	880
6A	36" x 72"	8	32	25	19	—	960
		10	20	15	—	—	1120
		4	140	115	90	60	740
		5	90	76	57	40	800
7	36" x 96"	6	64	50	39	27	860
		8	36	29	22	—	940
		10	22	18	—	—	1100
		4	186	145	110	72	935
		5	118	93	70	46	995
8	42" x 96"	6	80	64	49	32	1055
		8	46	36	28	—	1135
		10	28	23	17	—	1295
		5	160	125	95	63	1240
		6	105	86	66	43	1300
9	48" x 96"	8	62	50	38	24	1380
		10	40	30	23	—	1540
		12	27	22	16	—	1740
		6	140	112	87	56	1795
		8	82	65	50	32	1875
10	54" x 96"	10	50	40	30	20	2035
		12	36	28	21	—	2235
		14	26	21	16	—	2435
		6	180	144	110	72	2290
10	54" x 96"	8	104	82	63	40	2370
		10	65	52	40	26	2530
		12	45	36	27	—	2730
		14	33	26	20	—	2930

Erecting Instructions

Select the hook-up best meeting your requirements and make piping as shown.

Suction piping must be tight and tested for leaks.

Pump stuffing boxes must be fully packed and properly drawn up to prevent leakage.

If water seal is provided it must be examined to insure it is working correctly.

When air relief piping is used it should follow the pump suction to a point below the top of the sump but always be open to air.

Vacuum break is complete as shipped except that hook-ups 2, 3, 4, should be connected to the pump vent.

No foot valve is to be installed on suction pipe.

No check valve is to be installed between pump and primer.

A check valve may be used on final discharge from the primer.

Selection Data - Metric

Size	Dimensions, MM	Size Pipe, MM	Maximum Length of Suction Pipe Primers will Handle on These Lifts, Meters				Weight, kg, 345 kpa pressure
			1.524	3	4.6	6	
0	203 x 914	25	11.6	9.1	7.3	—	345
		38	4.6	3.7	—	—	345
1	254 x 1016	25	18.3	15.2	12.2	9.1	448
		38	9.1	7.6	6.1	—	448
		51	4.6	3.7	—	—	448
2	305 x 1219	25	35.1	29	22.9	16.5	689
		38	15.2	12.8	9.8	6.7	689
		51	10.7	7.3	4.9	—	689
		64	4.9	3.7	—	—	689
3	406 x 1219	38	35.1	29	22.9	15.2	1103
		51	18.9	15.2	11.6	7.9	1103
		64	12.2	9.8	7	—	1103
		76	7.9	6.1	4.6	—	1103
		—	—	—	—	—	—
4	508 x 1676	51	39.6	33.5	27.4	19.8	1931
		64	25.9	21.3	16.8	12.2	1931
		76	18.3	14.6	10.7	7.3	1931
		102	9.1	7.6	6.1	—	1931
		127	5.5	4.3	—	—	2344
		—	—	—	—	—	—
5	610 x 1829	64	48.8	39.6	30.5	21.3	2654
		76	35.1	28.7	21.3	13.7	2654
		102	19.8	15.8	12.2	7.6	2654
		127	12.2	9.8	6.7	—	3068
		152	7.6	6.1	4.9	—	3482
5A	762 x 1829	76	51.8	42.7	33.5	22.9	3620
		102	30.5	24.4	18.3	12.2	3620
		127	19.8	15.8	12.2	8.2	4033
		152	13.1	10.4	7.6	—	4447
		203	7.6	6.1	4.6	—	4999
6	762 x 2438	102	39	30.5	23.5	17.1	5240
		127	25	19.8	15.2	9.8	5654
		152	17.1	13.4	11	6.7	6067
		203	9.8	7.6	5.8	—	6619
		254	6.1	4.6	—	—	7722
6A	914 x 1829	102	42.7	35	27.4	18.3	5102
		127	27.4	23.2	17.4	12.2	5516
		152	19.5	15.2	11.9	8.2	5929
		203	11	8.8	6.7	—	6481
		254	6.7	5.5	—	—	7584
7	914 x 2438	102	56.7	44.2	33.5	21.9	6447
		127	36	28.3	21.3	14	6860
		152	24.4	19.5	14.9	9.8	7274
		203	14	11	8.5	—	7826
		254	8.5	7	5.2	—	8929
8	1067 x 2438	127	48.8	38.1	29	19.2	8549
		152	32	26.2	20.1	13.1	8963
		203	18.9	15.2	11.6	7.3	9515
		254	12.2	9.1	7	—	10618
		305	8.2	6.7	4.9	—	11997
9	1219 x 2438	152	42.7	34.1	26.5	17.1	12376
		203	25	19.8	15.2	9.8	12928
		254	15.2	12.2	9.1	6.1	14031
		305	11	8.5	6.4	—	15410
		356	7.9	6.4	4.9	—	16789
10	1372 x 2438	152	54.9	43.9	33.5	21.9	15789
		203	31.7	25	19.2	12.2	16341
		254	19.8	15.8	12.2	7.9	17444
		305	13.7	11	8.2	—	18823
		356	10.1	7.9	6.1	—	20202

Operating Instructions

Fill lower compartment with water which makes the installation ready to operate automatically and it will do so indefinitely if installation has been properly made.

On dirty, greasy water any failure to prime after first starting up is probably caused by clogging the vacuum break or air valve.

The primer does not affect the operation of the pump except to keep it primed at all times.

Sizes and Weights

APCO Primers are made for any desired capacity. Weights given in table are for 50 psi (345 kpa) working pressure. For working pressure over 50 psi (345 kpa), call for information.

Up to 4" (100 mm) standard NPT female connection.

5" (125 mm) and above 150# flange class connection.

Sales and Service

For information about our worldwide locations, approvals, certifications and local representative:

Web Site: www.dezurik.com E-Mail: info@dezurik.com



250 Riverside Ave. N. Sartell, Minnesota 56377 • Phone: 320-259-2000 • Fax: 320-259-2227

DeZURIK, Inc. reserves the right to incorporate our latest design and material changes without notice or obligation. Design features, materials of construction and dimensional data, as described in this bulletin, are provided for your information only and should not be relied upon unless confirmed in writing by DeZURIK, Inc. Certified drawings are available upon request.