

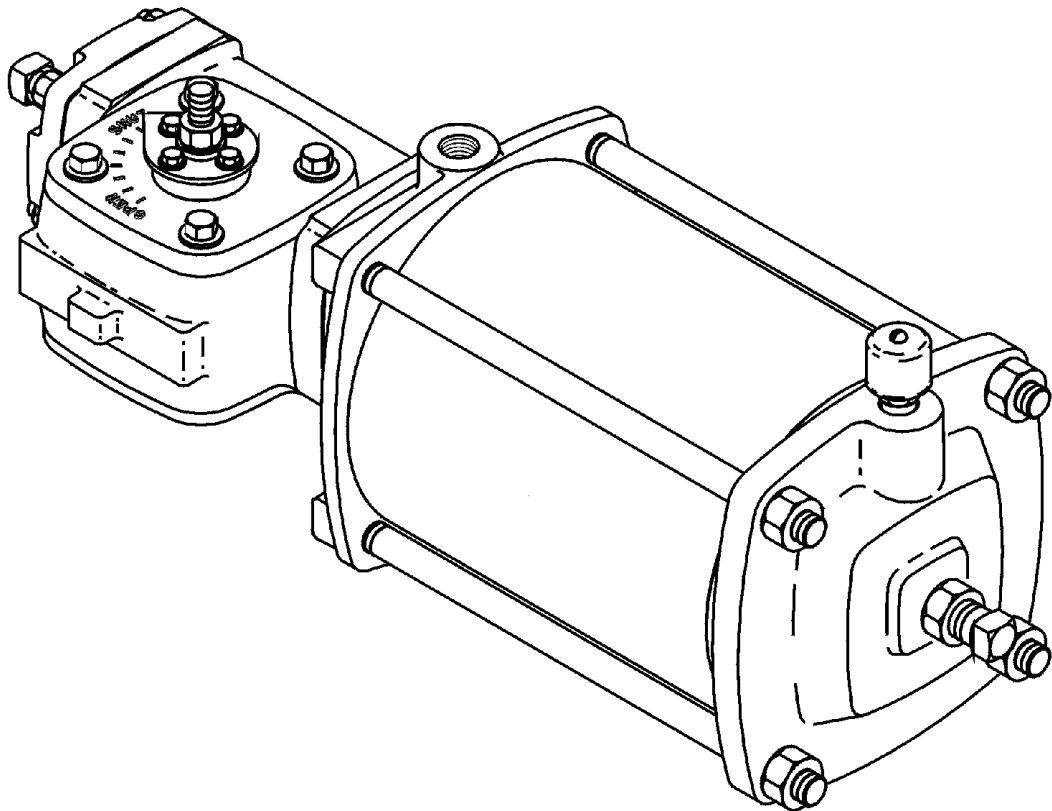

APCO | WILLAMETTE

DeZURIK POWERRAC SINGLE
CYLINDER SPRING-RETURN
ACTUATORS
For Square Shafts



Instruction D10396
June 2011

Instructions

These instructions provide information about the PowerRac™ single cylinder spring-return actuators. They are for use by personnel who are responsible for installation, operation and maintenance of PowerRac™ single cylinder spring-return actuators.

Safety Messages

All safety messages in the instructions are flagged with an exclamation symbol and the word Caution, Warning or Danger. These messages indicate procedures that must be followed exactly to avoid equipment damage, personal injury or death.

Safety label(s) on the product indicate hazards that can cause equipment damage, personal injury or death. If a safety label becomes difficult to see or read, or if a label has been removed, please contact DeZURIK for replacement label(s).



WARNING!

Personnel involved in the installation or maintenance of valves should be constantly alert to potential emission of pipeline material and take appropriate safety precautions. Always wear suitable protection when dealing with hazardous pipeline materials. Handle valves, which have been removed from service with suitable protection for any potential pipeline material in the valve.

Inspection

Your PowerRac™ single cylinder spring-return actuator has been packaged to provide protection during shipment; however, it can be damaged in transport. Carefully inspect the unit for damage upon arrival and file a claim with the carrier if damage is apparent.

Parts

Recommended spare parts are listed on the assembly drawing. These parts should be stocked to minimize downtime.

Order parts from your local DeZURIK sales representative, or directly from DeZURIK. When ordering parts, please include the 7-digit part number and 4-digit revision number (example: **9999999R000**) located on the data plate attached to the valve assembly. Also include the part name, the assembly drawing number, the balloon number and the quantity stated on the assembly drawing.

DeZURIK Service

DeZURIK service personnel are available to install, maintain and repair all DeZURIK products. DeZURIK also offers customized training programs and consultation services.

For more information, contact your local DeZURIK sales representative or visit our website at www.dezurik.com.

Table of Contents

Description - - - - -	4
Operation - - - - -	4
Installation - - - - -	4
<i>Spring-to-Close</i> - - - - -	5
<i>Spring-to-Open</i> - - - - -	5
Lubrication - - - - -	6
Position Stops - - - - -	6
Removing Actuator - - - - -	7
Actuator Disassembly - - - - -	7
Spring-Return Cylinder Disassembly - - - - -	9
Spring-Return Cylinder Reassembly - - - - -	10
Actuator Reassembly - - - - -	11
Mounting Actuator - - - - -	14
Changing Actuator from Spring-Return to Double-Acting - - - - -	15
Reversing Spring Action - - - - -	15
Changing Mounting Position - - - - -	15
Lockable Model - - - - -	16
<i>Unlocked Condition</i> - - - - -	16
<i>Locked Closed Position</i> - - - - -	17
<i>Locked Open Position</i> - - - - -	18
Troubleshooting - - - - -	19

Description

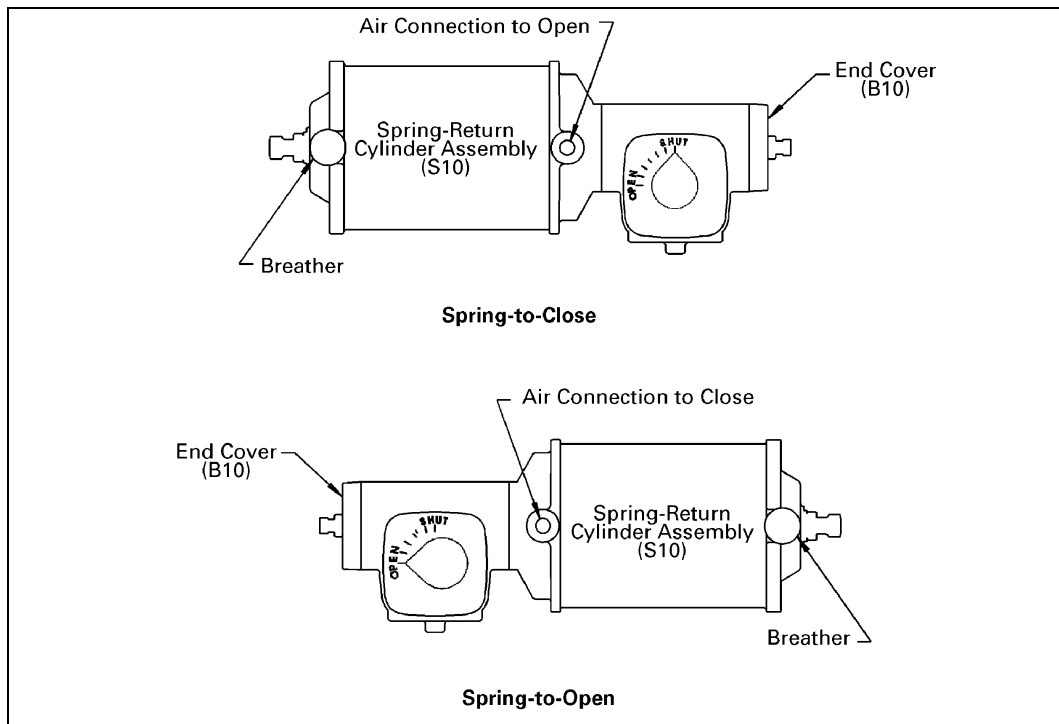

Figure 1 – Available Configurations

The PowerRac™ single cylinder spring-return actuator is a quarter turn enclosed rack and gear cylinder actuator. The PowerRac™ single cylinder spring-return actuator is used for on-off or modulating control on valves that have a square shaft connection. The R number designates the 1" radius of the actuator gear. A choice of 4" and 6" (100 mm and 150 mm) cylinder diameters is offered. The 4" cylinder is offered with one spring size while the 6" cylinder has two spring sizes.

The actuator is available as a spring-to-open or spring-to-close actuator. The spring action may be reversed by removing the spring-return cylinder assembly and mounting it on the opposite end of the gear housing.

A lockable model of the PowerRac™ single cylinder spring-return actuator is also available. See "LOCKABLE MODEL" section.

Operation

The PowerRac™ single cylinder spring-return actuator is powered pneumatically, and rotates 90° between the open and closed positions, in the direction as described in the "INSTALLATION" section. The spring-return cylinder is sized for a 60 psi (415 kPa) spring only, and is limited to 100 psi (690 kPa) maximum.

Installation

All cylinder port connections are ¼" NPT. The spring-return actuator requires one pneumatic connection as shown below.

Spring-to-Close

With a spring-to-close spring actuator, air to the connection drives the actuator counterclockwise, towards the “open” position on the dial.

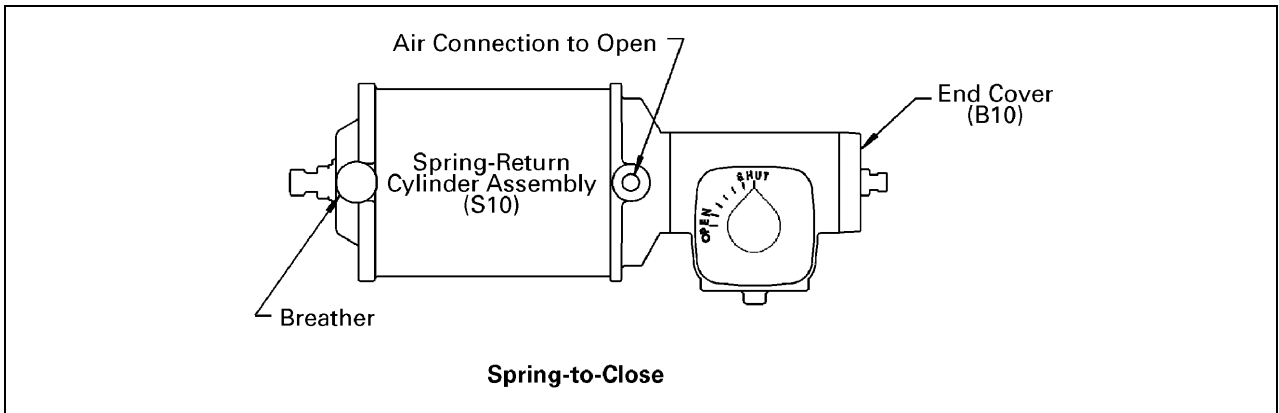

Figure 2 – Spring to close

Spring-to-Open

With a spring-to-open actuator, air to the connection drives the actuator clockwise, towards the “shut” position on the dial.

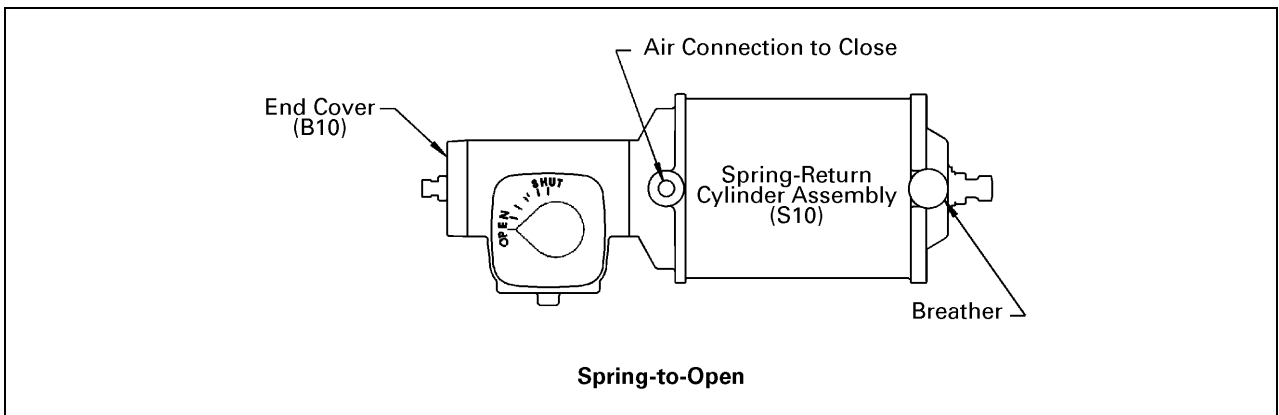

Figure 3 – Spring to open

As the spring-return actuator is cycled, air is alternately exhausted and drawn in through a breather. The breather is located at one end of the cylinder as shown in Figures 2 and 3. The breather must be protected from water because water inside of the actuator will cause sticking and premature wear of the internal components.

If the actuator is located outdoors or in an area that will be hosed down, the breather must be oriented vertically. The “umbrella” top of the breather will then prevent water from being drawn in through the breather. In locations that are submerged or subject to flooding, the breather must be removed and remotely piped to a protected location.

Lubrication

The actuator is lubricated at the factory, and does not require routine maintenance lubrication. If the actuator is disassembled, lubricate as described in the “ACTUATOR REASSEMBLY” section.

Position Stops

The adjustable open and closed position stops prevent the actuator from rotating beyond the open and closed positions of the valve. The adjustable stops are screws that are secured with jam nuts. The position stops are located in the extreme ends of the actuator as shown in Figure 4.

If the actuator is factory-mounted on the valve, the stops are preset and do not require further adjustment. If the actuator is not factory-mounted, or if the actuator is removed or disassembled, the stops will require adjustment as described below.

With a spring-to-open actuator, the closed position stop is located in the cylinder cap and the open position stop is located in the actuator end cover.

With a spring-to-close actuator, the open position stop is located in the cylinder cap and the closed position stop is located in the actuator end cover.

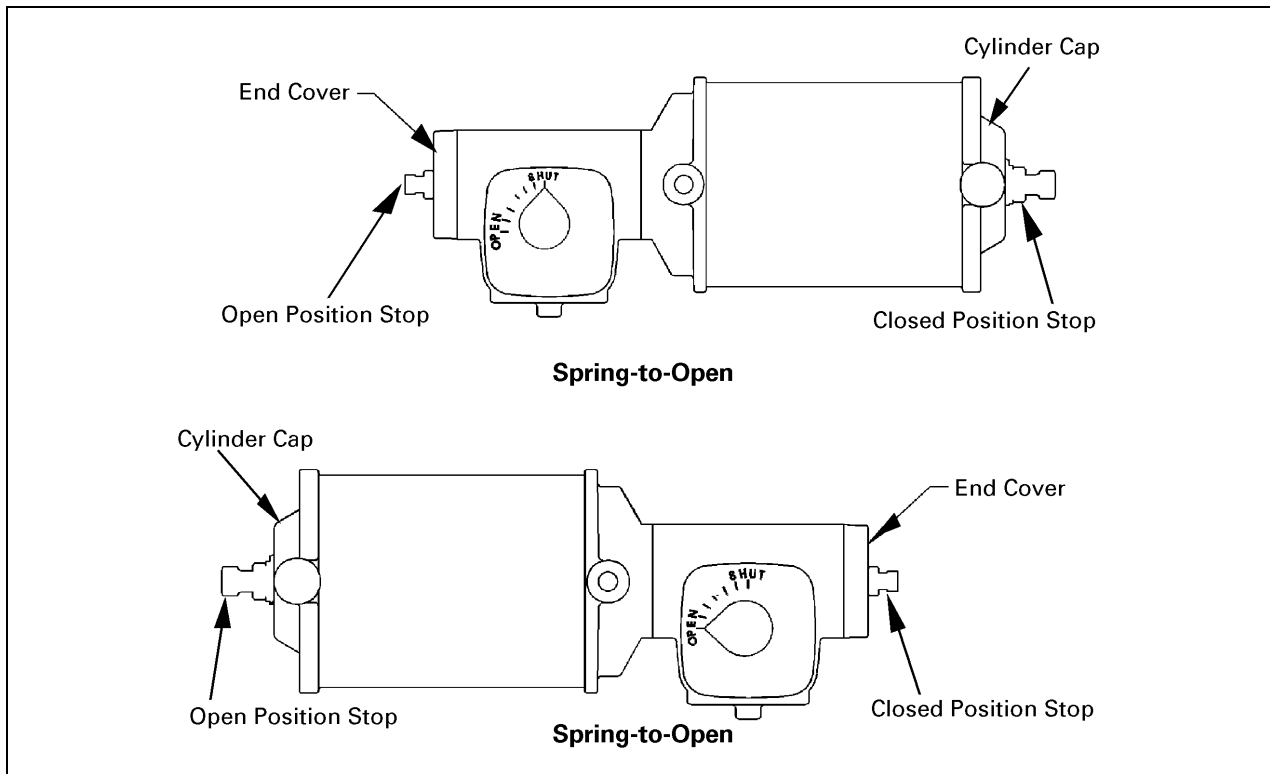

Figure 4 – Adjustable Stop Locations

To adjust either stop:

1. Adjust the stops after the actuator is mounted on the valve—refer to valve instructions for closed-position information.
2. Loosen the jam nut, and turn the screw counterclockwise to increase the stroke, or clockwise to decrease the stroke.
3. After the stop is adjusted to the desired position, hold the screw from turning, and tighten the jam nut to the torque value shown in Table A.

Position Stops *(Continued)***Table A: Jam Nut Torque**

Jam Nut	Foot pounds	Newton Meters
1/2" (13mm) Nut on 4" (100mm) Cylinder Cap	38±5	52±7
5/8" (16mm) Nut on 6" (150mm) Cylinder Cap	77±10	104±14
5/8" (16mm) Nut on End Cover	77±10	104±14

Refer to Figures 5 and 6 for component identification.

Removing Actuator

1. Shut down the flow in the pipeline.

**WARNING!**

Flow in the pipeline with the actuator removed can allow the valve to slam closed and cause personal injury and/or damage to the flow system. Shut down the flow in the pipeline before removing the actuator from the valve.

2. Disconnect and lock out the pneumatic power to the actuator to prevent accidental operation of the actuator.

**WARNING!**

Moving parts from unexpected operation of a powered actuator can cause personal injury or equipment damage. Disconnect and lock out power to the actuator before servicing.

3. Release the collet assembly (B9) from the valve shaft by loosening the jam nut (B9D) and the hex-socket set screw (B9A) that extends through the pointer (B9F) on top of the actuator.
4. Remove the four mounting screws (B26) that fasten the actuator to the valve.
5. Remove the actuator from the valve by lifting the actuator from the valve shaft.

Actuator Disassembly

Refer to Figures 5 and 6 for component identification.

1. Remove the four pointer screws (B9G), and remove the collet assembly (B9) and the pointer from the actuator.
2. Remove the four top cover screws (B15) and remove the top cover (B11).
3. Remove the top cover gasket (B13), the O-ring (B10) and the gear (B8).
4. Remove the four cylinder assembly nuts (B20) and lockwashers (B19), and remove the cylinder assembly (S00) and gasket (B16).
5. Remove the rack screw (B7) and lockwasher (B6), and separate the rack (B5) from the piston rod (S4) [Piston Rod Not Shown in Figure 5].
6. Remove the rack bearing (B3) from the pin (B4).
7. Remove the four end cover nuts (B20) and lockwashers (B19), and remove the end cover (B17) and gasket (B16).

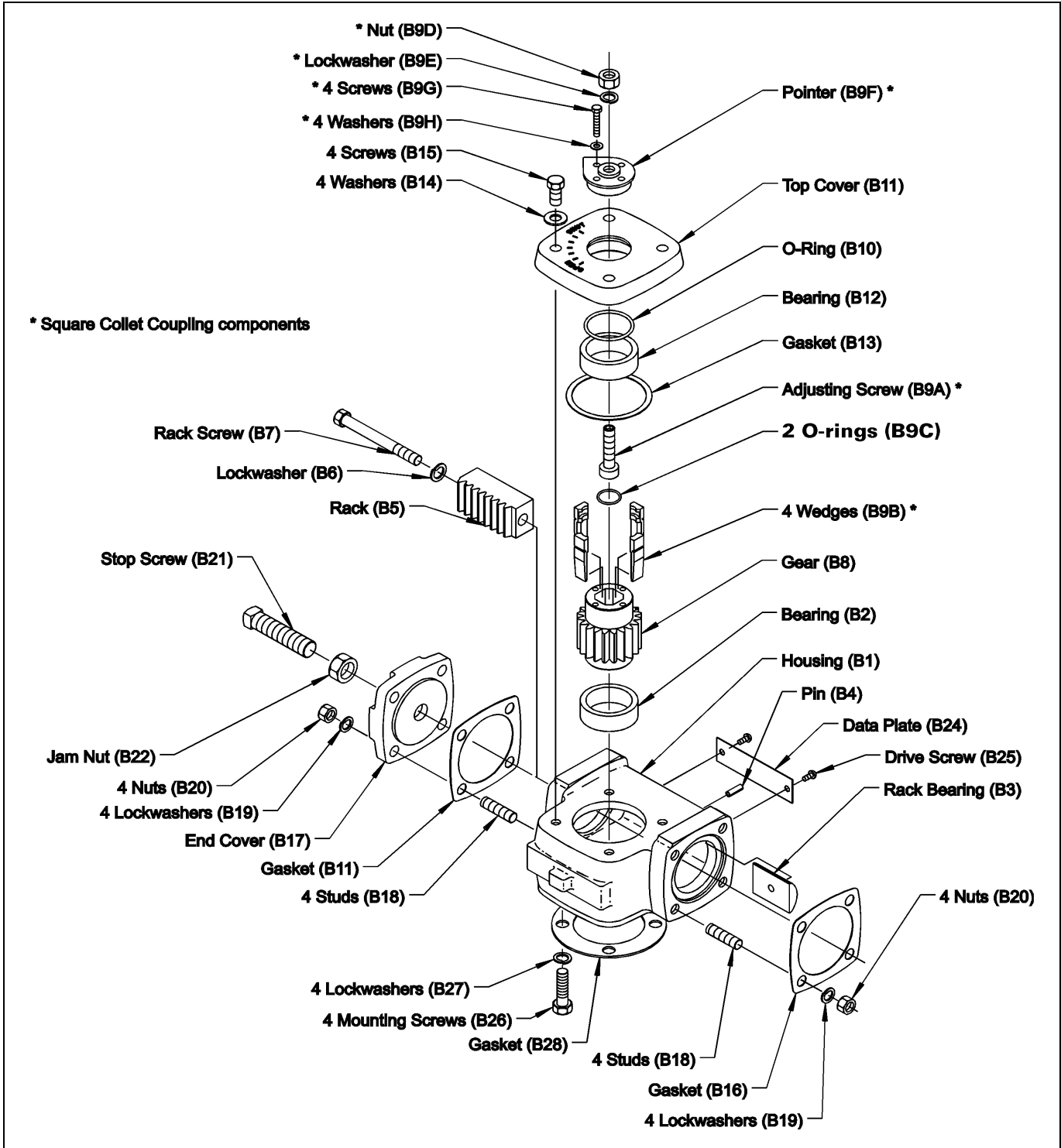

Figure 5 – Actuator Assembly, Less Cylinder

Spring-Return Cylinder Disassembly

Refer to Figure 6 for component identification.



WARNING!

The spring assembly (S19) contains a compressed spring that can cause death or personal injury if the cylinder tie rod nuts are removed while the spring force is on the tie rod nuts. DO NOT REMOVE THE CYLINDER TIE ROD NUTS UNLESS THE SPRING FORCE DECREASES TO ZERO!

1. Loosen the tie rod nuts (S15) on the tie rods (S12).

Note: Force from the spring assembly will be felt during the first few turns of the nuts. As the cylinder tie rod nuts are loosened, the force from the spring assembly must decrease to zero before the nuts can be removed from the tie rods. The nuts and washers (S13) may be removed safely after the force from the spring assembly decreases to zero.

If the spring force does not decrease to zero, re-tighten the nuts and contact the factory.

2. Remove the cylinder cap (S11).
 3. Push the piston rod (S4) through the cylinder head (S1) so that the spring assembly (S19) is accessible.
-



WARNING!

The spring assembly (S19) contains a compressed spring that can cause death or personal injury if the assembly is taken apart. DO NOT DISASSEMBLE THE SPRING ASSEMBLY!

4. Remove the spring assembly (S19) carefully from the cylinder tube (S6).

Note: Do not damage the cylinder wall with the spring assembly during this step. **Do not disassemble the spring assembly!**

5. Remove the cylinder tube (S6), the piston (S7) and the piston rod (S4) from the cylinder head (S1).
6. Remove the piston (S7) and the piston rod (S4) from the cylinder tube (S6).
7. Remove the piston nut (S10), the piston (S7) and the O-ring (S14) from the piston rod (S4).
8. Remove the piston seal (S9) and the O-ring (S8) from the piston (S7).
9. Remove the piston rod seal (S3) from the cylinder head (S1).
10. Remove the two cylinder tube O-rings (S5) from the cylinder head (S1) and from the cylinder cap (S11).

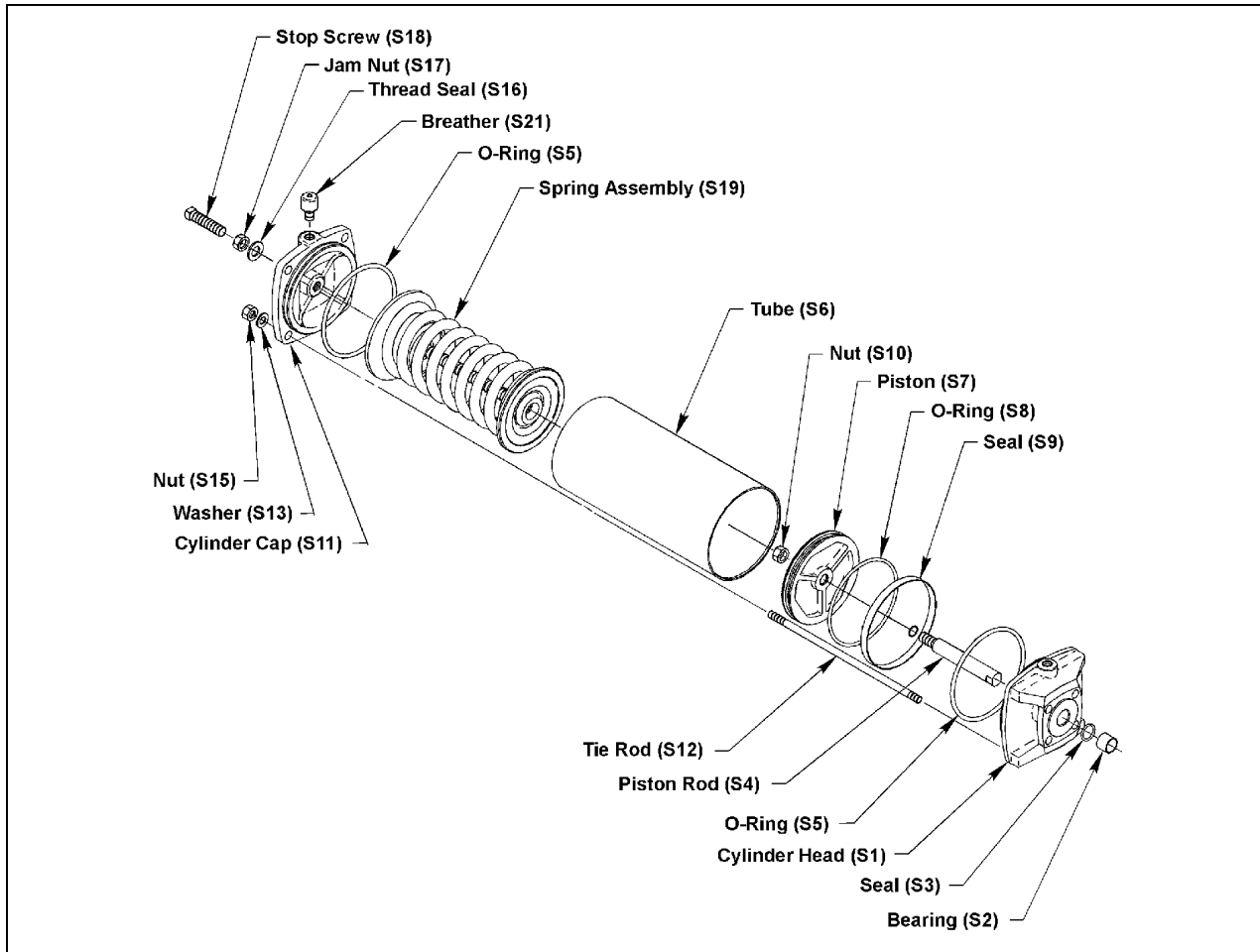

Figure 6 – Cylinder Assembly

Spring-Return Cylinder Reassembly

Clean and inspect all parts before reassembly. Refer to Figure 6 for component identification. See Figure 1 for orientation of cylinder assembly and end cover on spring-to-open and spring-to-close actuator configurations.

1. Replace worn parts, especially sealing components such as O-rings, other seals, and the cylinder tube.
2. Lubricate O-rings, other seals, and the cylinder tube walls with Dow Corning Molykote 44 grease, or equivalent.
3. With the O-ring and groove toward the piston rod, place the O-ring (S14), the piston (S7), and the nut (S10) on the piston rod (S4).
4. Tighten the nut to 45 ± 5 ft. lbs. (61 ± 7 Nm).
5. Place the O-ring (S8) in the smaller groove of the piston (S7). Place the piston seal (S9) in the larger groove of the piston as far around the circumference as possible without stretching the seal. Angle the remaining portion of the seal, and carefully slip it over the edge of the piston and into the groove.
6. Place the piston rod seal (S3) in the cylinder head (S1).

Spring-Return Cylinder Reassembly *(Continued)*

7. Push the piston rod (S4) through the cylinder head (S1) so that the piston (S7) is against the cylinder head.
8. Place the two cylinder tube O-rings (S5) in the groove in the cylinder head (S1) and in the groove in the cylinder cap (S11).
9. Using care to avoid damage to the piston seal (S9), replace the cylinder tube following the appropriate steps for the size:
 - a. If the cylinder tube (S6) diameter is 6" (150 mm), place the cylinder tube over the piston (S7) at about a 45° angle. Carefully square the cylinder tube into alignment with the piston, and push the cylinder tube into position on the cylinder head (S1).
 - b. . If the cylinder tube diameter is 4" (100 mm), push the cylinder tube on straight, without the angle.
10. Note the end of the spring assembly (S19) that has a 11/8" (29 mm) diameter machined hole. With the hole toward the piston (S7), carefully insert the spring assembly into the cylinder tube (S6) so that the hole fits over the piston nut (S10). Do not damage the cylinder wall with the spring assembly during this step.
11. Align the holes in the cylinder cap (S11) with the tie rods (S12) and insert the cylinder cap into the cylinder tube (S6). Place the tie rod nuts (S15) and washers (S13) on the tie rods. If the cylinder tube diameter is 4" (100 mm), tighten the 5/16" (8mm) nuts to 12±2 ft. lbs. (16±3 Nm); if the cylinder tube diameter is 6" (150 mm), tighten the 1/2" (13mm) nuts to 16±2 ft. lbs. (22±3 Nm).

Actuator Reassembly

Refer to Figure 5 for component identification.

Rack and Gear Assembly

1. Clean and inspect all parts before reassembly
2. Replace worn parts, especially sealing components such as the O-ring and gaskets.
3. Before reassembly, lubricate the following surfaces with a medium aluminum complex based grease such as Keystone Zeniplex-1:
 - The flat side of the rack bearing (B3)
 - Both bearing hubs of the gear (B8)
 - The top cover O-ring (B10) and the groove in the top cover (B11)
 - Both sides of the four wedges in the collet assembly (B9), and the mating four surfaces of the gear (B8).
 - The teeth in the rack (B5) and in the gear (B8)
4. Place the rack bearing (B3) on the pin (B4).

Note: A dab of grease on the curved side of the rack bearing will help to hold it in place.
5. Locate the witness mark on the teeth near one end of the rack (B5).

Actuator Reassembly (Continued)

6. Assemble the end of the rack opposite the witness marks to the end of the piston rod (S4) with the rack screw (B7) and lockwasher (B6)—do not tighten the screw.
7. With the pneumatic connections facing upwards (towards the top of the actuator), mount the cylinder assembly (S00) and the gasket (B16) to the housing (B1).

Note: For a spring-to-close actuator, use the four studs (B18) on the right-hand side of the housing, as viewed when facing the data plate (B24). For a spring-to-open unit, use the studs on the left-hand side of the housing.

8. Place the nuts (B20) and lockwashers (B19) on the studs and tighten the nuts to 15 ± 2 ft. lbs. (20 ± 3 Nm).
9. With the four tapped holes facing upwards, place the gear (B8) into the housing bearing (B2), and engage the gear teeth with the rack (B5) teeth so that the marked tooth on the rack and the two marked teeth on the gear are positioned as shown in Figure 7:

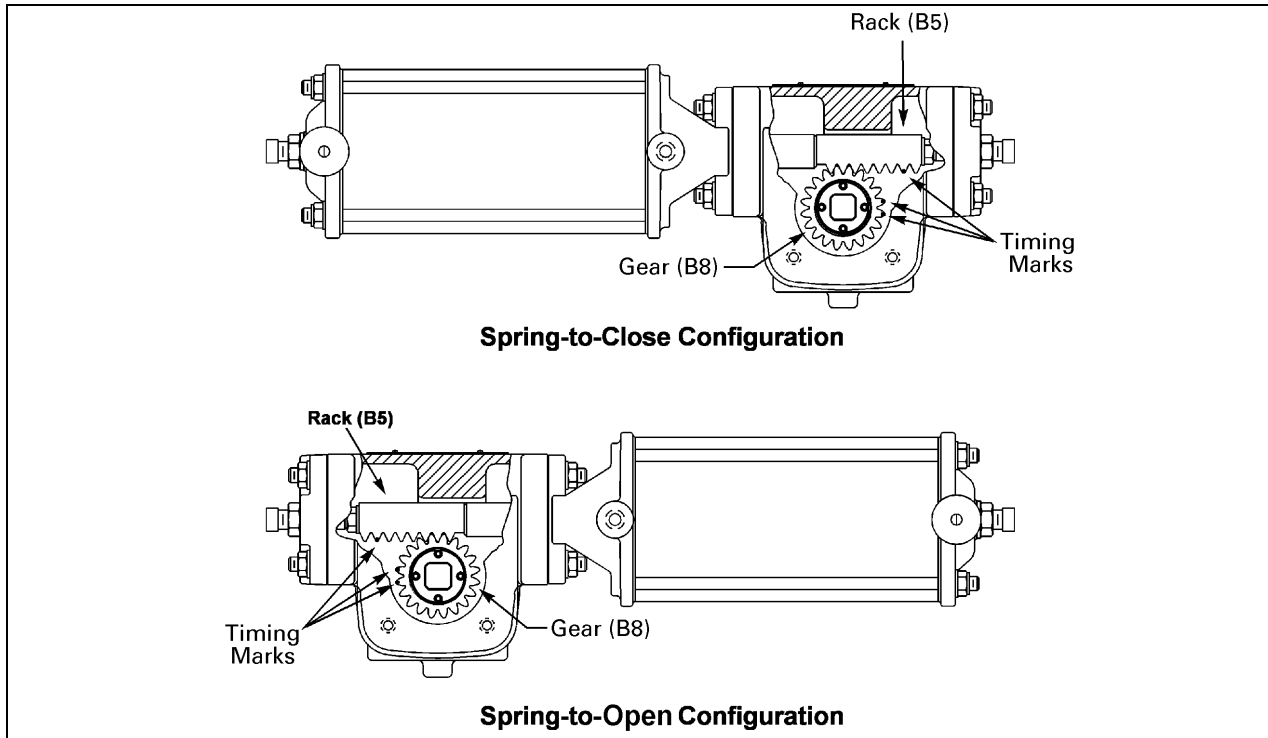

Figure 7 – Gear Alignment

Cover, Collet and Pointer Assembly

1. Place the O-ring (B10) in the groove of the top cover (B11).
2. Mount the top cover (B11) and gasket (B13) to the housing (B1) with the four screws (B15) and washers (B14) and tighten the screws to 15 ± 2 ft. lbs. (20 ± 3 Nm).
3. Place the actuator in the fail position (with the piston rod (S4) extended into the actuator) before the next step.
4. Tighten the rack screw (B7) to 35 ± 5 ft. lbs. (47 ± 7 Nm).

Actuator Reassembly *(Continued)*

5. Turn the jam nut (B22) onto the stop screw (B21), and turn the stop screw into the center hole in the end cover (B17) until the end of the stop screw protrudes about 1/4" (6 mm) through the end cover.
6. Tighten the jam nut (B22) finger-tight.
7. Mount the end cover (B17) and the gasket (B16) to the housing studs (B18) with the four nuts (B20) and lockwashers (B19) and tighten the nuts to 15±2 ft. lbs. (20±3 Nm).
8. Turn the adjusting screw (B9A) in the collet assembly (B9) so that the four wedges are about 1/32" (0.8mm) from the bottom of the pointer (B9F).
9. With the actuator in the fully open or closed position, place the collet assembly (B9) in to the opening in the gear (B8) and align the pointer (B9F) to the correct position on the top cover (B11). See Figure 8 for wedge configurations.
10. Mount the pointer to the gear with the four screws (B9G) and washers (B9H) and tighten to 18±2 inch lbs (2.0±0.2 Nm).

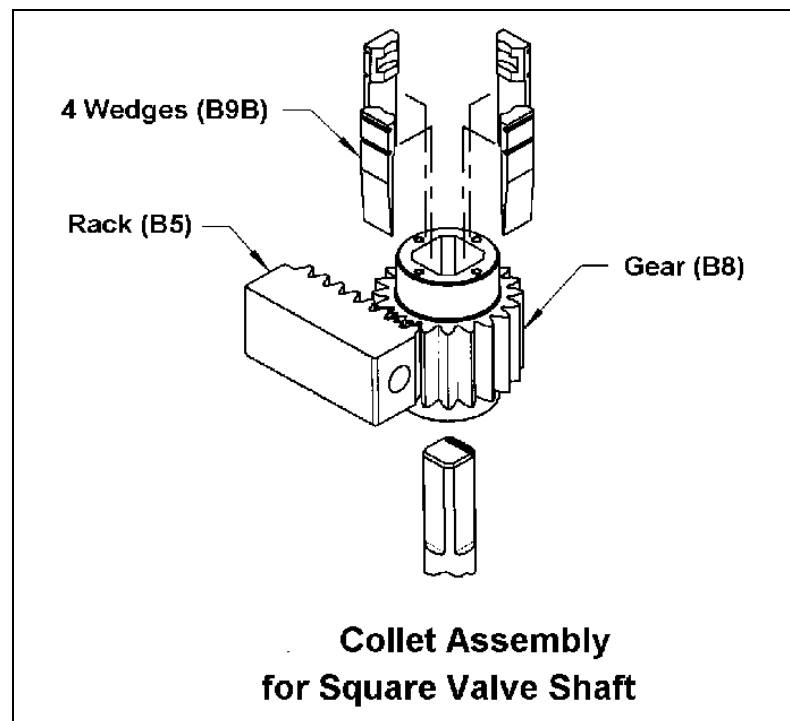
**Figure 8 – Wedge Configurations**

Mounting Actuator

Refer to Figure 5 for component identification.

1. Determine which of the four actuator-to-valve mounting positions is desired, as shown on the valve installation drawing.
2. Match the open or closed position of the valve with the open or closed position of the actuator.
3. Note the position of the word "OPEN" on the top cover (B11).
4. Position the cover on the housing (B1) so that dial hash mark for "OPEN" will be parallel with the pipeline when the valve is installed.

Note: One or more of the steps below may be required, depending upon the mounting position selected, the type of valve shaft, and the positions of the valve, actuator, and actuator cover.

- a. Rotate the valve shaft.
 - b. Stroke the actuator.
 - c. Select a different actuator-to-valve mounting position.
 - d. Remove and re-index the actuator cover:
Remove the four cover screws (B15), rotate the cover, and replace the four cover screws (B15) and washers (B14). Tighten the screws to 15 ± 2 ft. lbs. (20 ± 3 Nm).
5. If the actuator does not include the collet assembly (B9), grease and install the assembly as described in the "Actuator REASSEMBLY" SECTION.
 6. Place the gasket between the actuator and the valve, engage the actuator with the valve shaft in the desired mounting position as determined in step 1, and slide the actuator onto the valve shaft.

Note: Certain high-temperature valves include and require a high-temperature gasket (B28). If the valve includes a gasket, use the gasket included with the valve rather than the gasket included with the actuator.

7. Assemble the four actuator mounting screws (B26) with lockwashers (B27) up through the mounting holes in the top of the valve (or the actuator adaptor on the valve), through the gasket (B28), and into the threaded holes in the bottom of the actuator. Tighten the screws finger tight—so that the valve and actuator mounting surfaces are in contact, but are free to slide and self-center during the next step.
8. Tighten the adjusting screw (B9A) in the collet assembly (B9) to 16 ± 2 ft. lbs. (22 ± 3 Nm) if $3/8$ " (9.5mm), or to 22 ± 2 ft. lbs. (30 ± 3 Nm) if $1/2$ " (13mm).
9. Tighten the four actuator mounting screws (B26) to 15 ± 2 ft. lbs. (20 ± 3 Nm).
10. Loosen the adjusting screw (B9A) in the collet assembly (B9).
11. Re-tighten the four actuator mounting screws (B26).
12. Tap the adjusting screw with a rubber mallet so that the gear (B8) bottoms out against the lower housing bearing (B2).
13. Begin to tighten the adjusting screw (B9A); as the adjusting screw becomes snug, repeat step 11. Torque the adjusting screw to 16 ± 2 ft. lbs. (22 ± 3 Nm) if $3/8$ " (9.5mm), or to 22 ± 2 ft. lbs. (30 ± 3 Nm) if $1/2$ " (13mm).
14. Tighten the adjusting screw jam nut (B9D) tighten the screw to 16 ± 2 ft. lbs. (22 ± 3 Nm) if $3/8$ " (9.5mm), or tighten to 22 ± 2 ft. lbs. (30 ± 3 Nm) if $1/2$ " (13mm).

Mounting Actuator *(Continued)*

15. Adjust the open and closed position stops. See “POSITION STOPS”.
16. Operate the actuator and valve three full cycles to demonstrate that the unit operates smoothly in both directions.

Note: Do not exceed 100 psi (690 kPa) in cylinder.

Changing Actuator from Spring-Return to Double-Acting

Changing the actuator from spring-return to double acting requires a different cylinder assembly, which can be ordered from DeZURIK.

1. If the actuator is on a valve, remove the actuator from the valve. See “REMOVING ACTUATOR”.
2. Disassemble the actuator. See “ACTUATOR DISASSEMBLY”.
3. Assemble the actuator as described in the “Double-Acting Actuator Reassembly” section of the instructions furnished with the double acting cylinder.
4. Replace the actuator on the valve as described in the “MOUNTING ACTUATOR” section of the double acting cylinder instructions.

Reversing Spring Action

1. If the actuator is on a valve, remove the actuator from the valve. See “REMOVING ACTUATOR”.
2. Disassemble the actuator. See “ACTUATOR DISASSEMBLY”.
3. Assemble the actuator as described in the “ACTUATOR REASSEMBLY”, following the instructions for the desired spring action.
4. Replace the actuator on the valve. See “MOUNTING ACTUATOR”.

Changing Mounting Position

The actuator may be mounted in any of four positions on the valve.

The mounting position may be changed as follows:

1. Remove the actuator from the valve. See “REMOVING ACTUATOR”.
2. Replace the actuator on the valve. See “MOUNTING ACTUATOR”.

Lockable Model

The PowerRac™ Single Cylinder Spring-Return Actuator is available as a lockable model that allows the actuator to be locked in either the open or closed position. The lockable model is identified by PRL in the catalog characteristic.

As shown in Figures 10 and 11, the lockable model has a notched gear (B8) and an enlarged housing (B1) that includes two lock screws (B64) and two jam nuts (B65). A lockout cover assembly (B60) is also included.



WARNING!

The gear (B8) will be damaged if either of the stop screws is placed in an intermediate position between the unlocked and locked positions. The two lock screws (B64) must be in either the unlocked or the locked position as described in the following sections.

Unlocked Condition

Under normal unlocked operating conditions, both of the lock screws are backed out of the housing to allow the gear to rotate freely in either direction. To be fully disengaged, the distance from the housing to the end of each lock screw must be at least 2¼" (57 mm). To hold the lock screws in position, tighten the jam nuts to 38±5 ft. lbs. (52±7 Nm).

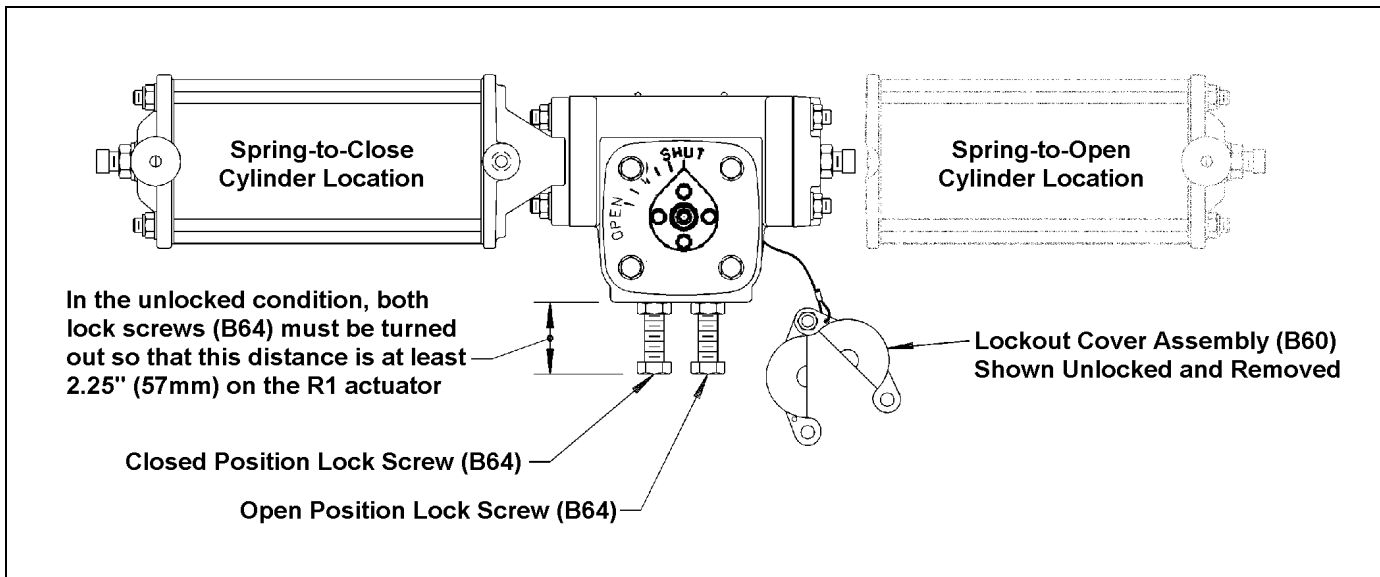

Figure 9 – Unlocked Condition

Lockable Model (Continued)**Locked Closed Condition**

Follow the steps below to change the unit from the unlocked condition to the locked closed position. Refer to Figure 10 for component identification. Before proceeding, ensure the open and closed position stops are properly adjusted as described in the “POSITION STOPS”

1. Operate the actuator to the fully closed (clockwise) position.

**WARNING!**

Adjusting the wrong screw does not lock the actuator, and can result in personal injury or equipment damage. Adjust only the LEFT-SIDE lock screw to lock the actuator in the closed position.

2. Loosen the jam nut (B65) on the **left** side lock screw (B64), as viewed when facing the top of the heads of the lock screws.
3. Hold the lock screw from turning, and turn the jam nut several turns counterclockwise, to the head of the lock screw.
4. Turn the **left** side lock screw clockwise several turns until resistance is felt from the lock screw contacting the notch in the gear (B8).
5. Tighten the lock screw to 5 to 10 ft. lbs. (7 to 14 Nm) to assure that the lock screw is contacting the gear.
6. Turn the **left** side jam nut clockwise against the actuator housing, then hold the lock screw and tighten the jam nut to 38 ± 5 ft. lbs. (52 ± 7 Nm).
7. Place and lock the lockout cover assembly (B60) on the head of the **left** side lock screw.

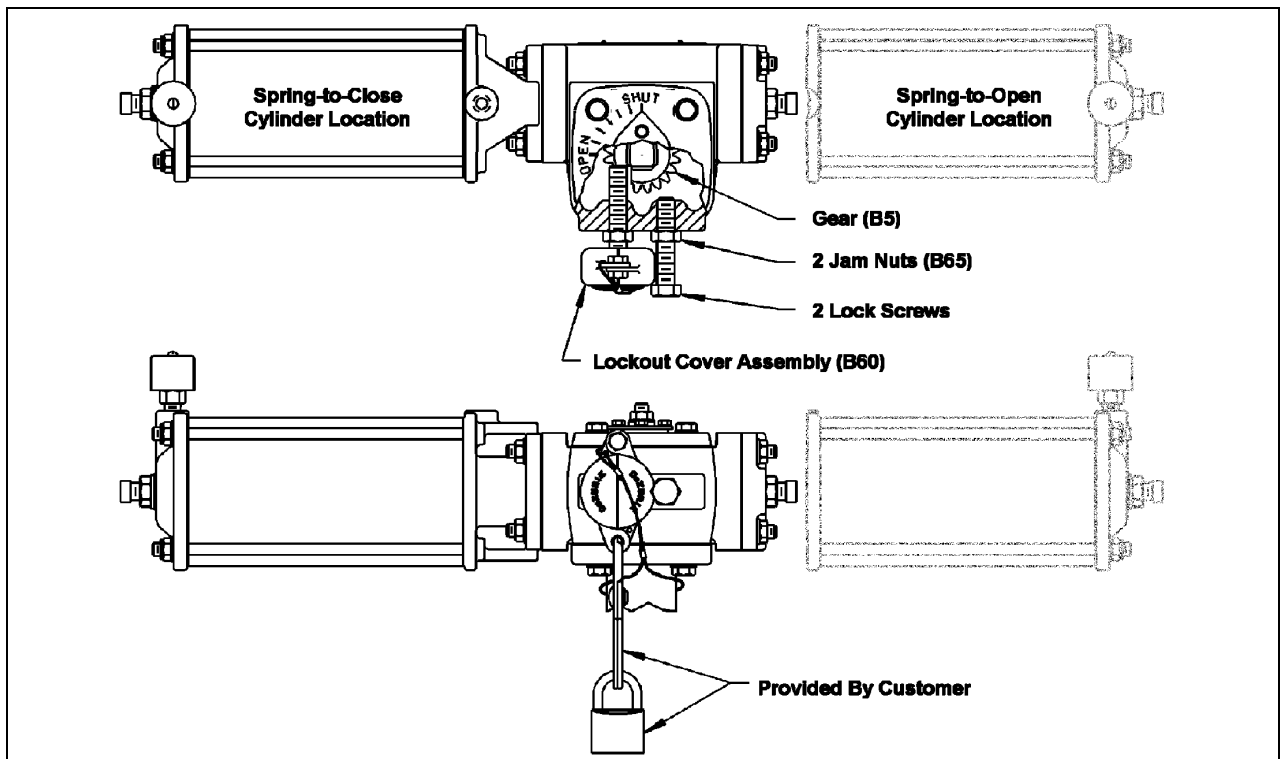

Figure 10 – Locked Closed Condition

Locked Open Condition

Follow the steps below to change the unit from the unlocked condition to the locked open position. Refer to Figure 11 for component identification. Before proceeding, ensure the open and closed position stops are properly adjusted as described in the “POSITION STOPS”

1. Operate the actuator to the fully open (counterclockwise) position.



WARNING!

Adjusting the wrong screw does not lock the actuator, and can result in personal injury or equipment damage. Adjust only the RIGHT-SIDE lock screw to lock the actuator in the open position.

2. Loosen the jam nut (B65) on the **right** side lock screw (B64), as viewed when facing the top of the heads of the lock screws.
3. Hold the lock screw and turn the jam nut several turns counterclockwise, to the head of the lock screw.
4. Turn the **right** side lock screw clockwise several turns until resistance is felt from the lock screw contacting the notch in the gear (B8).
5. Tighten the lock screw to 5 to 10 ft. lbs. to assure that the lock screw is contacting the gear.
6. Turn the **right** side jam nut clockwise against the actuator housing. While holding the lock screw from turning, tighten the jam nut to 38 ± 5 ft. lbs. (52 ± 7 Nm).
7. Place and lock the lockout cover assembly (B60) on the head of **right** side lock screw.

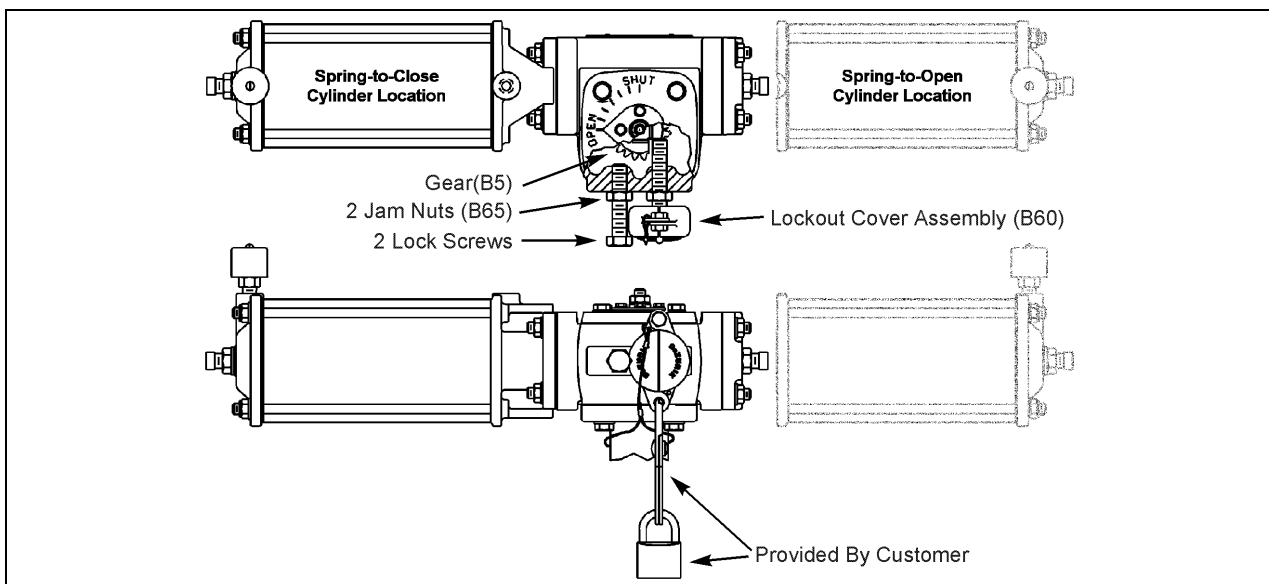

Figure 11 – Locked Open Condition

Troubleshooting

Condition	Possible Cause	Corrective Action
Actuator closes to wrong position	Closed position stop is set incorrectly	Adjust the closed position stop.
Actuator opens to wrong position	Open position stop is set incorrectly	Adjust the open position stop.
Actuator will not fully operate valve	Cylinder pressure is low	Increase cylinder pressure. Do not exceed 100 psi (69 kPa).
	Actuator is sized incorrectly	Use larger actuator
	Piston seal in cylinder is leaking	Replace piston seal(s).
	Obstruction in valve is preventing valve from closing.	Remove obstruction
	Lockable Model is locked.	Place in unlocked condition.
Valve fails in wrong direction with spring-return actuator	Actuator is assembled incorrectly.	Reverse spring action.