

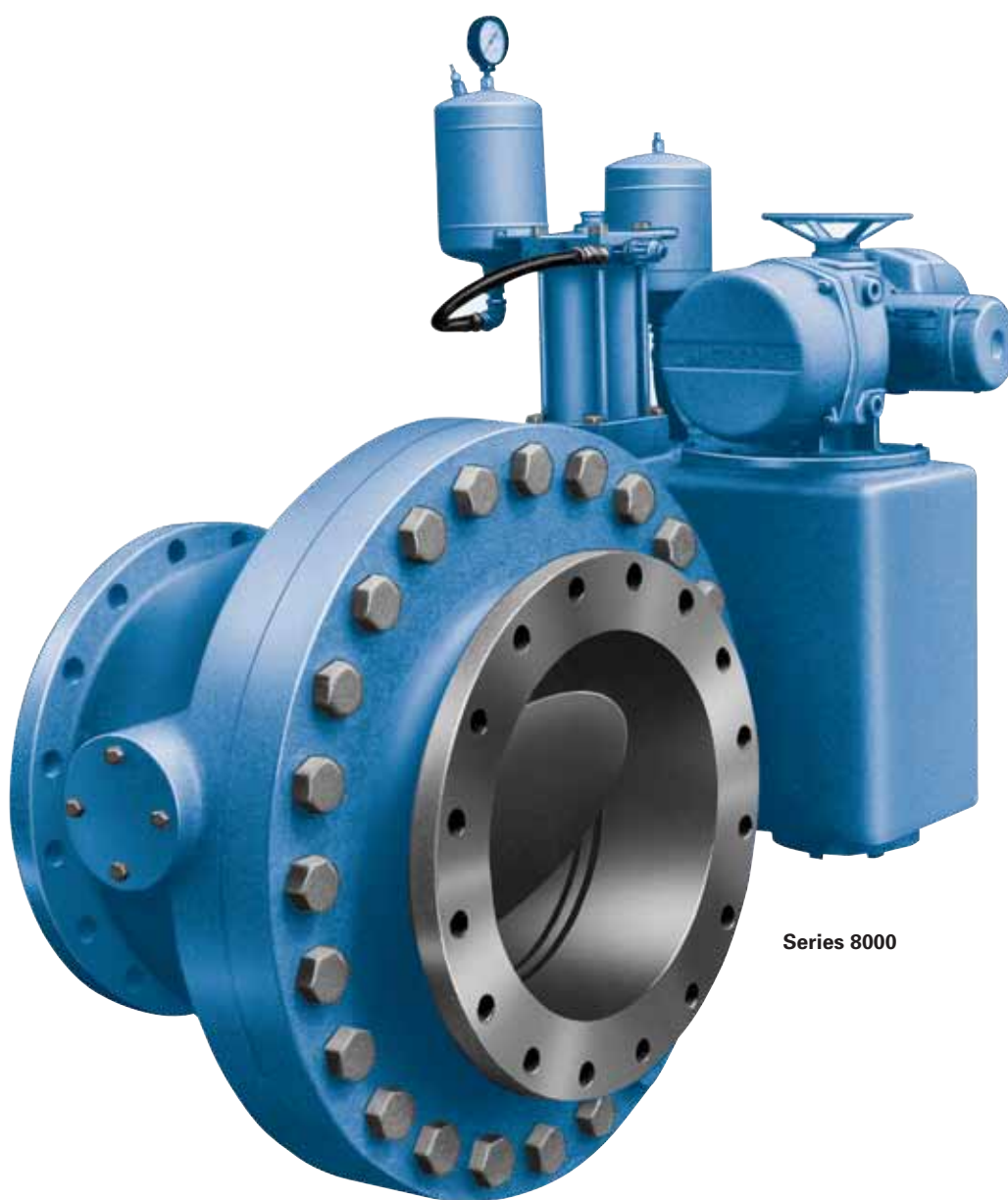

APCO AUTOMATIC CONTROL CHECK VALVES



Series 8000

Series 8000

What it is

The Automatic Control Check Valve (ACCV) is a multi-purpose valve offering the engineer a new approach to pump discharge control. These valves combine the functions of Flow Control, Check Valve, Shut-off Valve and Reverse Flow (Drain Valve) in a single unit. Available in a wide range of materials and sizes, APCO Control Valves are ideally suitable for automatically controlled water pumping stations. The design and operation is simple and understandable. Any maintenance required can be handled by municipal plant operating personnel. For eventual seat replacement the valve need not be removed from the line!

Why it Should be Used

The purpose of this valve is to greatly reduce pressure surges in pipelines resulting from pump start-ups and pump shutdowns even during electrical power failures!

Key features of this valve are its Offset Shaft, Disc, Replaceable Seat and Slip Gear Operator. Under flow conditions media pressure below the shaft portion of the disc is greater than the upper portion tending to open the disc while reversal flow tends to close it.

The unique form of the sealing elements (valve body seat and disc), by means of the offset shaft virtually eliminates seating and unseating torques and when the valve opens, the disc immediately separates from the seat. When it closes, the stainless disc ring is pressed tightly against the uniquely designed body seat without any rubbing or pinching effect. This valve design is in a class by itself because of the elimination of the seating and unseating torque problems usually present in valves of conventional design.

Where to Put it

This valve functions independently in four ways:

1. Check Valve
2. Flow Control Valve
3. Shut-Off Valve
4. Drain Valve

The APCO ACCV is most suitable for use as a Pump Discharge Control Valve in water and wastewater pumping stations. This valve is also ideally suited for use on the discharge of backwash pumps where flow control is essential to prevent upsetting the filter beds. The features that the APCO ACCV has over other valves commonly used for pump control is Fail Safe Closure* (regardless of power failure to the motor operator or pressure loss to the cylinder operator). Fail safe because the valve is flow sensitive, and through it's unique design of slip gearing, the valve will automatically close without need of an auxiliary power source when flow reverses. Closing is at a controlled rate through the built-in hydraulic cylinder with adjustable fluid circuits allowing three stages of closure.

***Note: Except when being used in the Drain Valve function.**

Engineer Reminder

Use an expansion coupling on the discharge side of the pump, so the valve body half may be dismantled and seat removed without removing the main valve from the line.

125# and 250# Classes							125# Class					250# Class				
Size	A	B	C	D	E	F	G	H	J	Dia. of Holes	No. of Holes	G	H	J	Dia. of Holes	No. of Holes
6" 150	15" 381	27.5" 699	10" 254	23.25" 591	8.75" 222	9.75" 248	11" 279	1" 25	9.5" 241	.875" 22	8	12.5" 317	1.438" 37	10.625" 270	.875" 22	12
8" 200	16.5" 419	27.75" 705	10.25" 260	23.5" 597	9.25" 235	9" 229	13.5" 343	1.125" 29	11.75" 298	.875" 22	8	15" 381	1.625" 41	13" 330	1" 25	12
10" 250	18.5" 470	31.5" 800	12.125" 308	24.75" 629	11.25" 286	8.75" 222	16" 406	1.188" 30	14.25" 362	1" 25	12	17.5" 445	1.875" 48	15.25" 387	1.125" 29	16
12" 300	20" 508	33.25" 845	13.75" 349	25" 635	12.75" 324	8" 203	19" 483	1.25" 32	17" 432	1" 25	12	20.5" 521	2" 51	17.75" 451	1.25" 32	16
14" 350	22" 559	37.25" 946	15.25" 387	25.25" 641	14" 356	6.5" 165	21" 533	1.375" 35	18.75" 476	1.125" 29	12	23" 584	2.125" 54	20.25" 514	1.25" 32	20
16" 400	24" 610	37.25" 946	16.5" 419	37.5" 953	15.5" 394	8.75" 222	23.5" 597	1.438" 37	21.25" 540	1.125" 29	16	25.5" 648	2.25" 57	22.5" 572	1.375" 35	20
18" 450	25.5" 648	40" 1016	19.5" 495	37.75" 959	18.25" 464	7" 178	25" 635	1.563" 40	22.75" 578	1.25" 32	16	28" 711	2.375" 60	24.75" 629	1.375" 35	24
20" 500	27" 686	40.25" 1022	19.75" 502	38" 965	18.5" 470	6.5" 165	27.5" 699	1.688" 43	25" 635	1.25" 32	20	30.5" 775	2.5" 64	27" 686	1.375" 35	24
24" 600	32.75" 832	41.5" 1054	25" 635	50" 1270	22.5" 572	6" 152	32" 813	1.875" 48	29.5" 749	1.375" 35	20	36" 914	2.75" 70	32" 813	1.625" 41	24
30" 750	38" 965	42" 1067	26.25" 667	50.25" 1276	25" 635	5" 127	38.75" 984	2.125" 54	36" 914	1.375" 35	28	43" 1092	3" 76	39.25" 997	2" 51	28
36" 900	42" 1067	45" 1143	34" 864	50.75" 1289	29" 737	4" 102	46" 1168	2.375" 60	42.75" 1086	1.625" 41	32	50" 1270	3.375" 86	46" 1168	2.25" 57	32
42" 1100	48" 1219	—	39" 991	—	34" 864	—	53" 1346	2.625" 67	49.5" 1257	1.625" 41	36	57" 1448	3.688" 94	52.75" 1340	2.25" 27	36
48" 1200	54" 1372	—	43" 1092	—	38" 965	—	59.5" 1511	2.75" 70	56" 1422	1.625" 41	44	65" 1651	4" 102	30.75" 781	2.25" 57	40

Inch
Millimeter

Motor operator includes start and stop push button station.

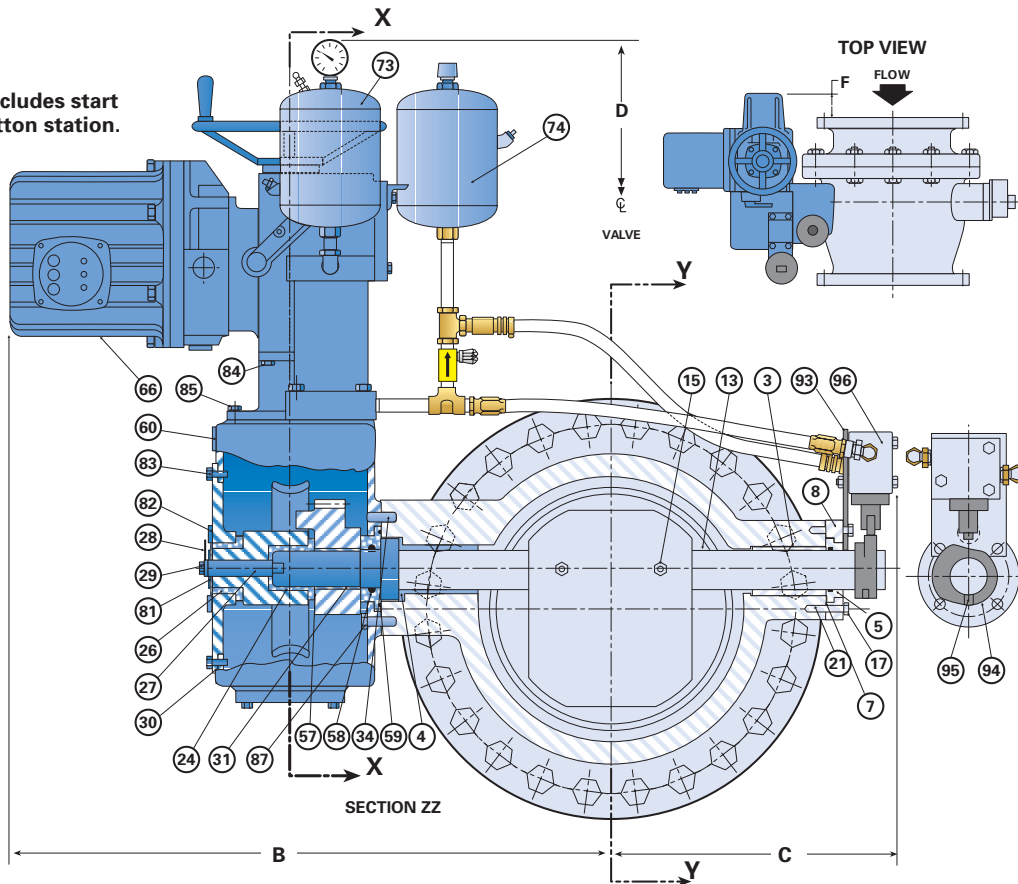

Shipping Weights (Approximate)													
Size	6"	8"	10"	12"	14"	16"	18"	20"	24"	30"	36"	42"	48"
Model	8006	8008	8010	8012	8014	8016	8018	8020	8024	8030	8036	8042	8048
125# Class	700 318	800 363	1350 612	1500 680	2100 953	2650 1202	3200 1451	4500 2041	6800 3084	8500 3856	11500 5216	13500 6123	17000 7711
250# Class	725 329	825 374	1370 621	1530 694	2250 1021	2775 1259	3350 1520	5000 2268	7300 3311	8800 3992	12000 5443	14000 6350	17775 8063

Inch Pounds
Millimeter Kilograms

Automatic Control Check Valves

DET.	DESCRIPTION	MATERIAL
1	Body Pivot Half	Cast Iron ASTM A 126 Cl. B
2	Valve Body Half	Cast Iron ASTM A 126 Cl. B
3	Straight Pivot Bushing	Bronze ASTM B584
4	Flanged Pivot Bushing	Bronze ASTM B584
5	Pivot Shaft Seal Retainer	Bronze ASTM B584
6	Body Seat Ring W/Reinforcing Ring	Buna-N / Steel
7	Pivot Shaft End Seal	Buna-N
8	Pivot Shaft Cover	Cast Iron ASTM A48 CL. 30
9	Disc Ring Seal	Buna-N
10	Disc	Ductile Iron ASTM A536
11	Disc Ring	Bronze ASTM B584
12	Disc Ring Ret. Screw	Stainless Steel 18-8
13	Pivot Shaft	Stainless Steel 17-4PH
14	Pivot Shaft Key	Stainless Steel T416
15	Pivot Shaft Set Screw	Stainless Steel 18-8
16	Disc Stop	Stainless Steel T304
17	Pivot Shaft Cover Bolt	Steel ASTM A307 GR. B
18	Flange Bolt	Steel ASTM A307 GR. B
19	Disc Stop Ret. Screw	Stainless Steel 18-8
20	Flange Nut	Steel ASTM 563 Gr. A
21	Pivot Shaft Cover - Seal	Buna-N
22	Flange Seal	Buna-N
23	Gear Segment	Steel ASTM A148
24	Wormwheel Internal Bushing	Bronze ASTM B584
25	Wormwheel	Ductile Iron ASTM A536
DET.	DESCRIPTION	MATERIAL
26	Wormwheel External Bushing	Bronze ASTM B584
27	Indicator Shaft	Brass B16
28	Disc Position Indicator	Brass B16
29	Disc Position Indicator Set Screw	Alloy Steel H.T.
30	Wormwheel Cover	Ductile Iron ASTM A536
31	Gear Segment Key	Steel AISI 1018
32	Rack Roller	Stainless Steel ASTM 582
33	Rack Roller Shaft	Alloy Steel H.T.
34	Gear Housing Polarizing Pin	Alloy Steel H.T.
35	Worm Shaft Cover	Steel AISI 1018
37	Wormshaft	Steel AISI 1018
38	Wormshaft Thrust Bearing	Steel Comm'l
39	Thrust Bearing Lock Washer	Steel AISI 1018
40	Gear Housing	Ductile Iron ASTM A536
41	Wormshaft Radial Bearing	Steel Comm'l
42	2nd Reduction Spur Gear	Ductile Iron ASTM A536
43	2nd Reduction Spur Gear Key	Steel AISI 1018
44	Spur Gear Ret. Ring	Stainless Steel Comm'l
45	Drive Pinion Shaft Bottom Bushing	Bronze ASTM B584
46	Drive Pinion Shaft	Steel AISI 1045
47	Drive Pinion Shaft Top Bushing	Bronze ASTM B584
48	Top Cover Plate	Ductile Iron ASTM A536
49	Operator Key	Steel AISI 1018
50	Pinion Shaft Bottom Bushing	Bronze ASTM B584
51	Pinion Shaft	Steel AISI 1045
DET.	DESCRIPTION	MATERIAL
52	1st Reduction Spur Gear Key	Steel AISI 1018
53	1st Reduction Spur Gear	Ductile Iron ASTM A536
54	Pinion Shaft Top Bushing	Bronze ASTM B584
55	Rack	Steel AISI 1018
57	Pivot Shaft Thrust Bearing	Bronze ASTM B584
58	Pivot Shaft Seal	Buna-N
59	Pivot Shaft Thrust Bearing Seal	Buna-N
60	Name Plate	Aluminum
63	Dashpot Cylinder	Steel Comm'l
66	Motor Operator	Commercial
73	Hydro-Pneumatic Accumulator	H.R. Steel Comm'l Quality
74	Oil Reservoir	H.R. Steel Comm'l Quality
81	Control Position Indicator	Brass B16
82	Dial	Brass B16
83	Wormwheel Cover Belt	Steel ASTM A307 Gr. B
84	Operator Mounting Bolt	Steel ASTM A307 Gr. B
85	Gear Housing Top Cover Bolt	Steel ASTM A307 Gr. B
86	Wormshaft Cover Bolt	Steel ASTM A307 Gr. B
87	Gear Housing Ret. Bolt	Steel ASTM A307 Gr. B
88	Dashpot Ret. Bolt	Steel ASTM A307 Gr. B
92	Thrust Bearing Lock Screw	Steel ASTM A307 Gr. B
93	Timing Valve Bracket	Steel AISI 1018
94	Timing Valve Cam	Cast Iron ASTM A48 Cl. 30
95	Cam Set Screw	Alloy Steel H.T.
96	Timing Valve	Aluminum Alloy 2024 - T351

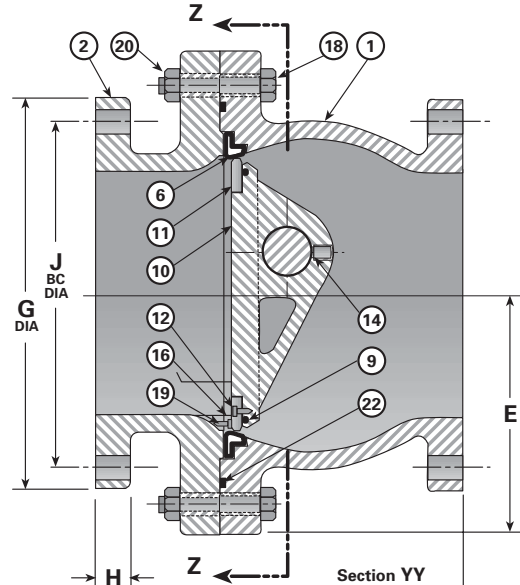
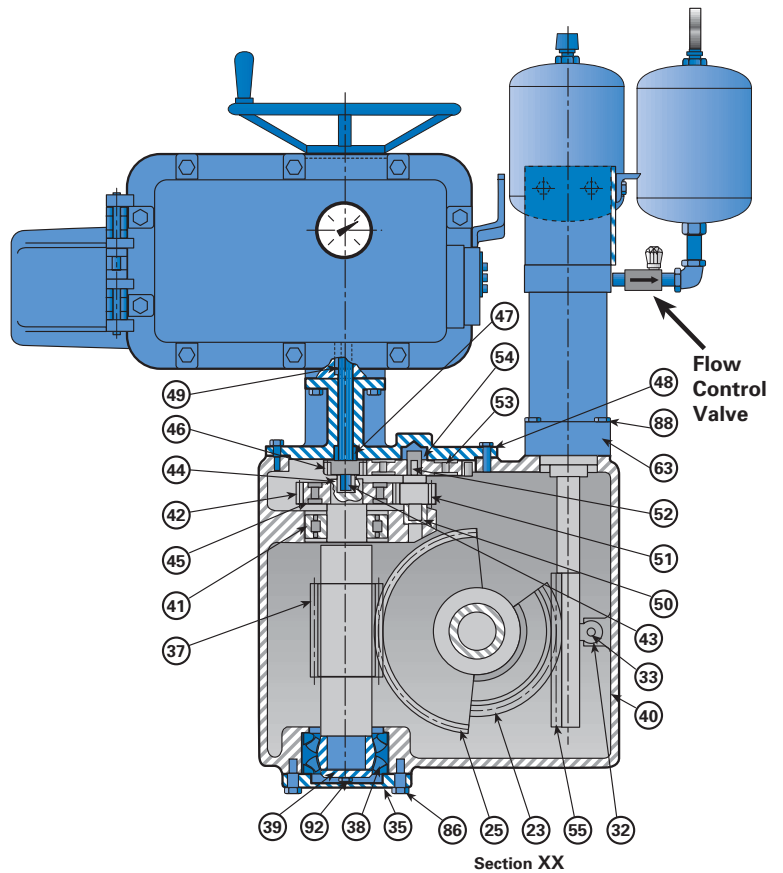

Advantages

- Hand replaceable seat
- Full flow area throughout
- Lower pressure drop
- Can be manually operated to act as an isolation valve
- Will operate as a standard check valve
- Can be used as a flow throttling valve by positioning the slip gear in the desired position
- Position indicators show degree of opening
- Bubble tight seating, replaceable in the field
- Can be opened for reverse flow to prime a pump, back flush or to drain system for repairs
- Optional metal to metal seating available

More advantages:

- This valve simplifies design and eliminates the need for several shut-off valves and valve bypasses which creates considerable savings in construction.

Finally, lower head loss than other type valves used for this purpose and short compact lay length means savings in pumping power and space in the pump house.

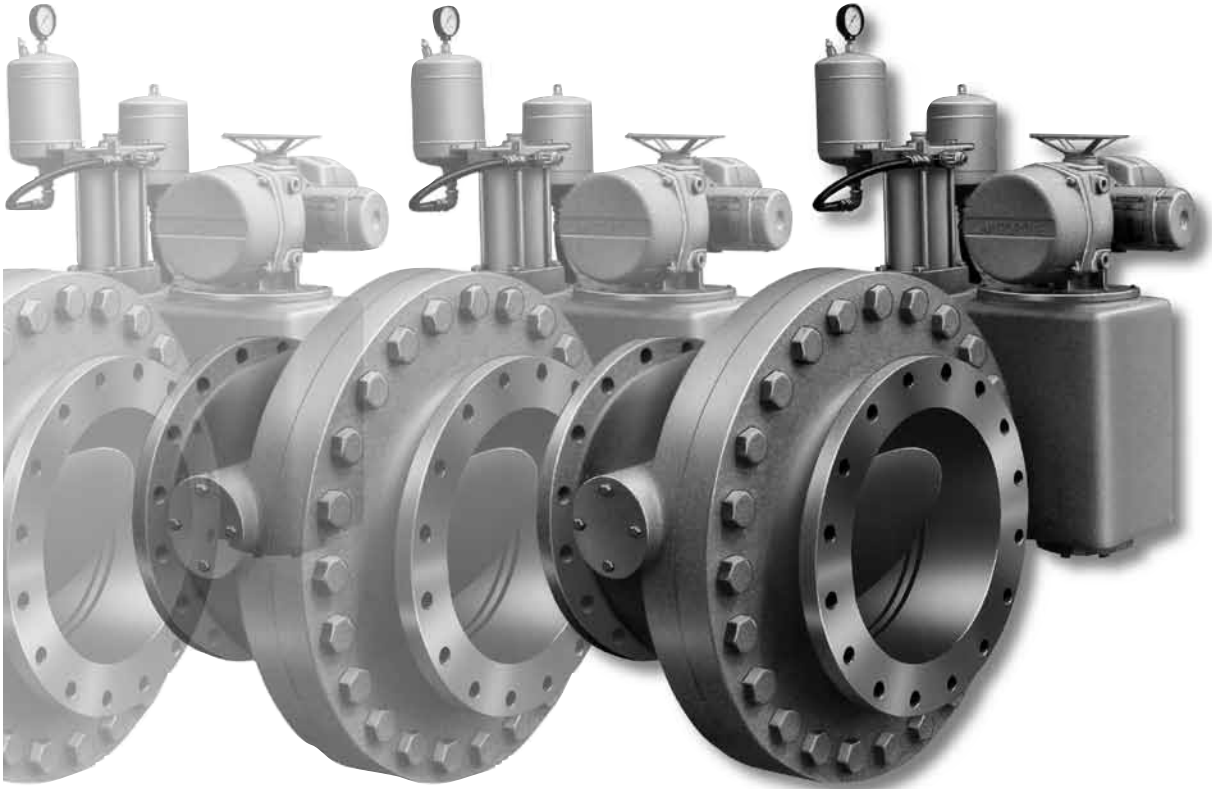

Data & Materials:

APCO Automatic Control Check Valves come in sizes 6" to 48" (150 to 1200mm). Larger size valves can be made to order.

Standard pressure ratings up to 300# class, but valves suitable for higher line pressure can be made to specifications. Pressure differential across the disc should be limited to 150 psi (1034 kpa).

APCO Automatic Control Check Valves are made standard with cast iron bodies, stainless steel shafts and ductile iron discs. Ductile iron and steel bodies are available for higher pressures. The valve shaft is high strength alloy stainless steel. The seat is Buna-N steel reinforced. Bearing material is of the highest quality bronze exceeding AWWA standards. Special epoxy coatings available.

Slip Gear Operator

The gap between the contact surfaces of the wormwheel and gear segment is called the "slip gear travel." This slip gear allows the check valve feature to function.

When you turn the handwheel or motor operator (69) clockwise, it turns the wormshaft (37) clockwise through the speed reducing gear train (40). This wormshaft controls the positioning of the wormwheel (25) which rotates freely on the shaft (13). The wormwheel then pushes gear segment (23) and disc (10), which are both keyed to the shaft, clockwise tending to close the valve. The gear segment meshes with the rack gear (55), which is directly connected to the dashpot cylinder (63).

Index

- 1 Valve Body (2 Pieces)
- 6 Replaceable Resilient Seat
- 10 Disc
- 13 Shaft
- 19 Hydro-Pneumatic Pressure Tank Assembly
- 20 Oil Reservoir Assembly
- 23 Gear Segment
- 25 Wormwheel
- 37 Wormshaft
- 40 Speed Reducing Gear Train
- 55 Rack
- 63 Dashpot Cylinder
- 64 Flow Control Valve (2)
- 69 Handwheel or Motor Operator

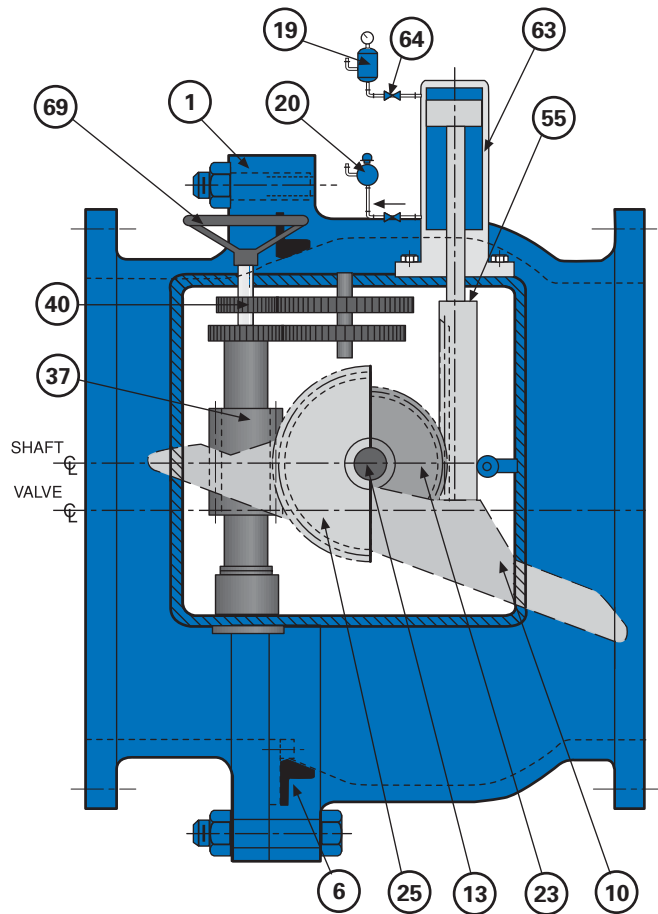

Section Thru Slip Gear Operator

Fail Safe

The slip gear operator is fail safe. It will not interfere with disc closure during normal check valve function, normal throttle flow function and normal electrical power close function! Nor will it interfere during any of these functions under emergency conditions due to loss of electrical power.

NOTE: Except when in the Drain Valve function

All Telling Indicator

The top half of the indicator shows various disc positions. The lower half shows various control positions (actual position of wormwheel). The two pointers move independently of each other. The longer arrow shaft which points to the disc position, is directly connected to the shaft. The shorter arrow is mounted on the wormwheel which rotates freely on the shaft.

Referring to the control position indicator (lower half), the distance from "check" to "c" is the power close travel, meaning the valve will control flow in the normal direction, but has the ability to freely close if there is a reversal flow. The distance from "check" to "o" is the power open travel, meaning the wormwheel will force the disc to open thereby controlling flow in the reverse direction.



Graduated Indicator

APCO Modern Design

vs

Conventional Design

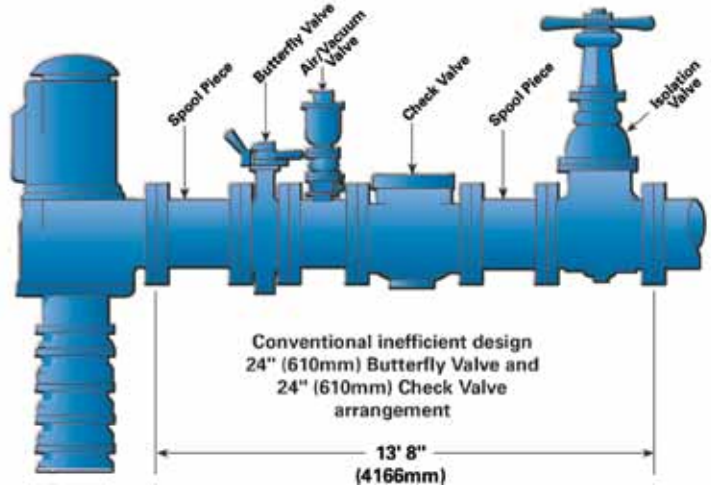
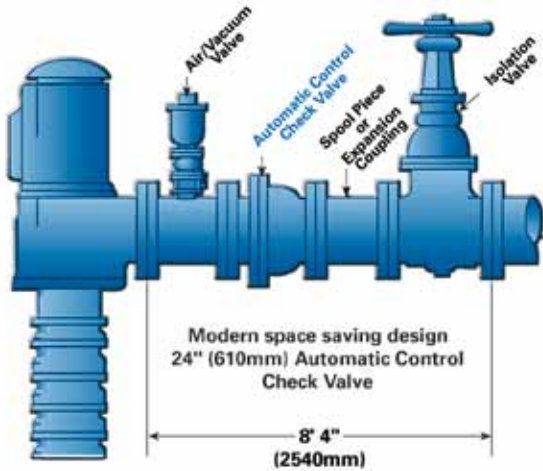

APCO ACCV's are more modern and efficient than valves of conventional design. Their multi-purpose functions simplify pump station design and the full flow globe body compensates for the area occupied by the disc which greatly minimizes the head loss through the flow section of the valve. Because of the smooth flow area and compact laying length, APCO ACCV's save power and valuable space in the pump station.

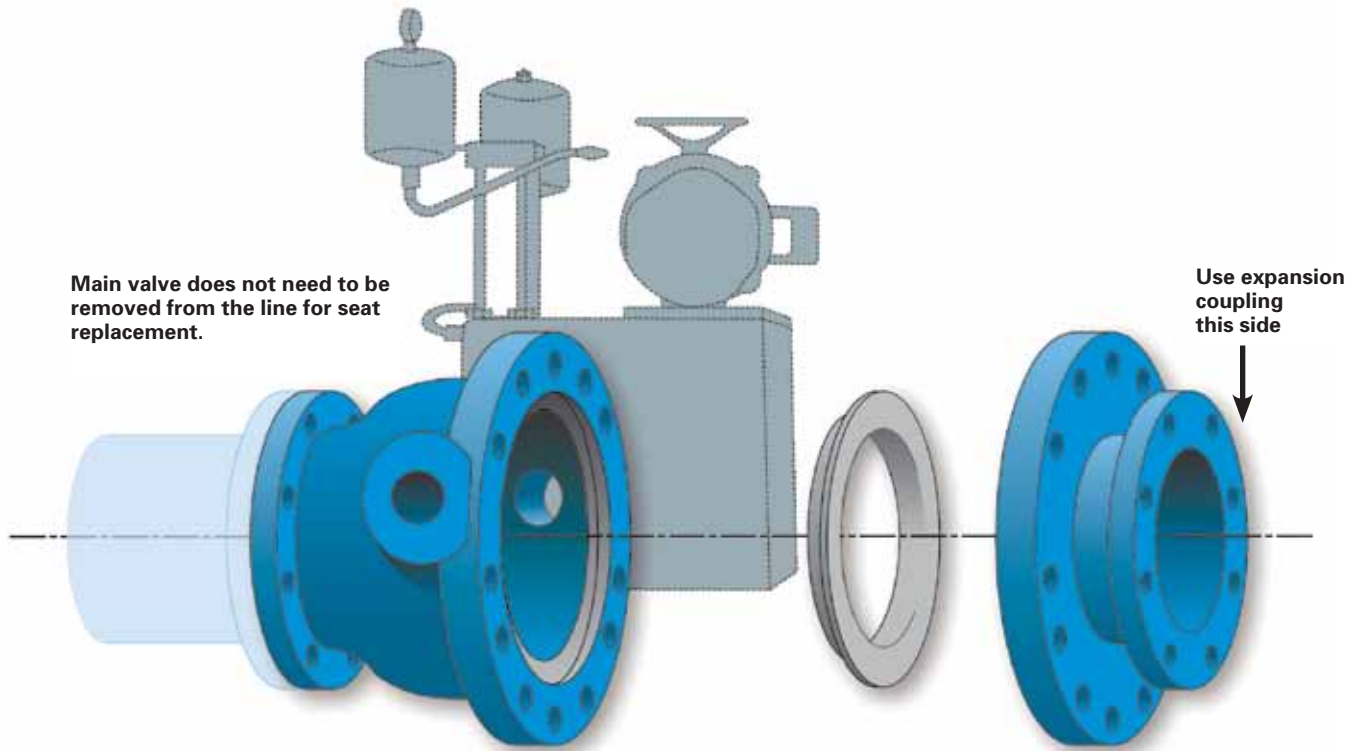

Eventual Seat Replacement

When that time inevitably comes, it is simple, uncomplicated and easily accomplished in the field by the pump station operating personnel.

Three Automatic Valves in One

1. Check Valve Function

The gap between the contact surfaces of the wormwheel and gear segment is called the "slip gear travel." This slip gear allows the check valve feature to function. Operating as a Check Valve the dashpot cylinder assembly fully controls disc movement with adjustability of open/close timing to suit the installation, thereby controlling the pressure surges and water hammer. The dashpot has three adjustable controlling stages: 1. The primary control is the Timing Valve (96). 2. The secondary control is the Flow Control Valve (64, figure A). 3. The third control is located in the cylinder and provides additional control over the last 10% of disc travel. The top Flow Control Valve controls rate of opening while the bottom one controls rate of closing. The dashpot cylinder is self contained and uses oil as a controlling media, creating a completely closed system which eliminates potential problems of corrosion, electrolysis and mineral deposits all too often present in water operated dashpots.

Note:
The electrical limit settings (Limitorque) are factory set for power close function.

2. Flow Control (Throttling) Function

The valve can be set to function as a Flow Control Valve in the normal flow direction.

This is attainable by positioning the wormwheel in the desired position (as in figure B). In this mode the disc is free to move from the throttle position to fully closed, therefore the disc is still able to perform as a check valve.

The valve can also be set to control backflow (in the reverse direction of normal flow). See Drain Valve Function below.

3. Shut-Off Function

This valve has the ability to also function as a Shut-off Valve as shown in figure C. The valve disc is tightly closed when the wormwheel is rotated clockwise to its closed position. In this position, the wormwheel has locked the segment gear and disc in the closed position and the disc cannot move regardless of pressure on either of it's sides. The factor of pressure tightness, as noted on the normal flow side of the disc in figure C (150 psi, 1034 kpa), is in reality a pressure differential factor. In other words, if the pressure in the reverse flow direction against the disc is 100 psi (689 kpa), a shut-off pressure of 250 psi (1724 kpa) on the normal flow side of the disc is attainable.

Plus a 4th

4. Drain Valve Function

As a Drain Valve (back flow valve), the valve allows flow in the reverse direction, to drain the system, backflush or prime the pump, as shown in figure D.

Caution: When set to function as a Back Flow Control Valve as in figure D, the disc is free to move from the set position to full open, consequently the disc will not close and the check feature is voided. After back flow or draining is completed the gear operator must be returned to the check or shut-off position for the valve to shut-off and be back to check valve function.

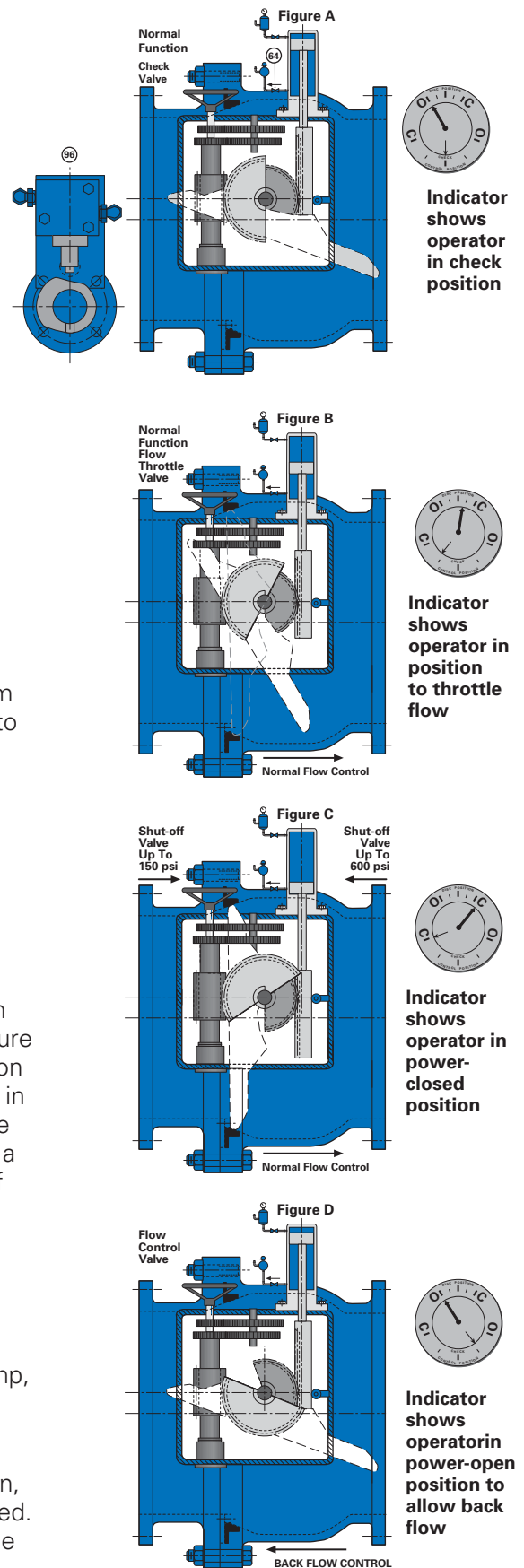

Automatic Control

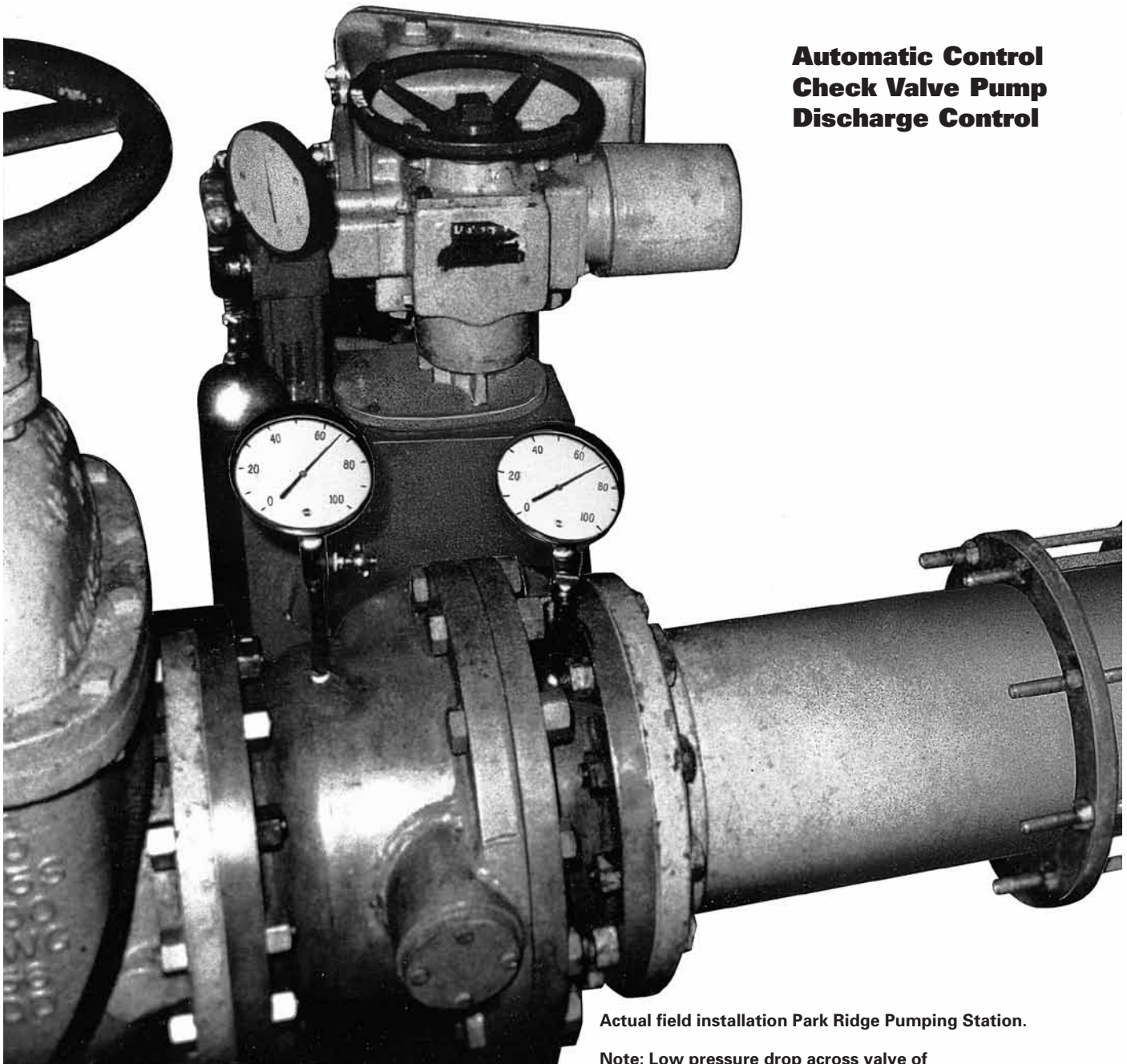

**Automatic Control
Check Valve Pump
Discharge Control**

Actual field installation Park Ridge Pumping Station.

**Note: Low pressure drop across valve of
approximately 1 psi (7 kpa).**

After years of numerous distribution pipeline breaks, it was determined water hammer (pressure surges) was the culprit, and Consoer Townsend was hired to solve the problem.

The conventional check valves were eliminated and the pump stations totally automated and modernized utilizing APCO Automatic Control Check Valves. Now pipeline breaks are a rarity or non-existent.

Timing Valve

Primary Control - Disc Closure Speed

The Timing Valve is unique with the APCO Automatic Control Check Valve. This Timing Valve is an extremely convenient and positively reliable valve to automatically open or close an oil passage. The built-in Timing Valve Roller is activated by the Timing Valve Cam, causing a resultant movement of the Timing Valve Stem to open or close the oil passage. When the roller is fully extended the oil passages inside the Timing Valve are fully closed. When the roller is depressed into the Timing Valve the oil passages are opened permitting unrestricted oil flow from the Automatic Control Check Valve Dashpot Cylinder to an atmospheric oil reservoir. This unrestricted oil flow allows easy movement and extremely rapid closure of the valve disc.

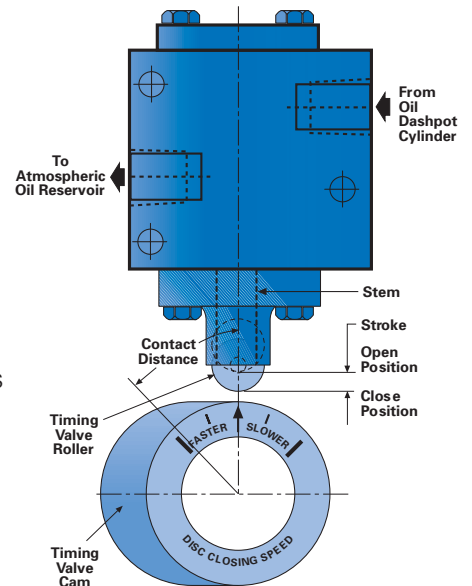

By adjusting the contact distance between the Timing Valve Cam and Timing Valve Roller, the most desirable time period of disc closure can be achieved in the field! The further the contact distance, the slower the primary rate of disc closure, the closer the contact distance, the faster the primary rate of disc closure. Therefore, by varying the contact distance between the cam and roller the valve disc can be made to close very rapidly from full open position to any degree of closure and still maintain control.

This is a most desirable feature to minimize the volume of water reversal during a pump shut-down sequence.

Typical Power Failure Closing Characteristics Automatic Control Check Valves

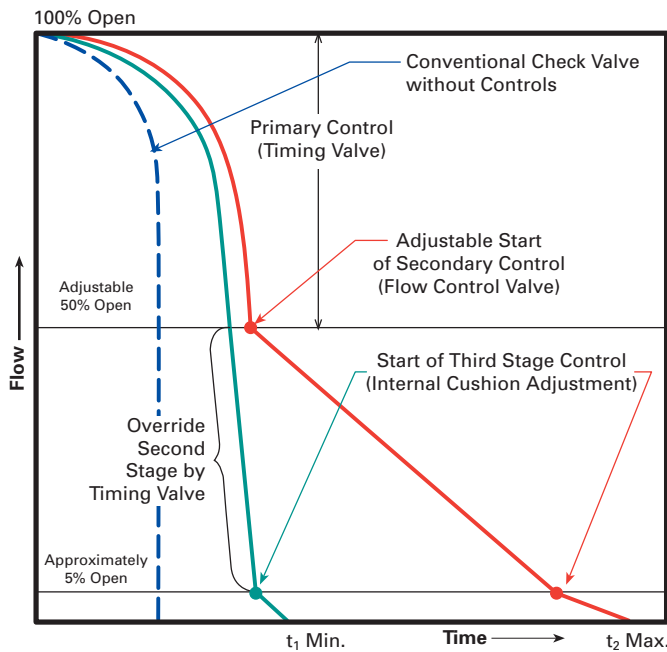

The controlled opening and closing times achieved by the Oil Dashpot and Timing Valve System will prevent or minimize damaging water hammer. The graph above shows flow rate as a function of closing time and illustrates clearly the superiority of APCO Automatic Control Check Valves. By adjusting flow in the Timing Valve and Oil Dashpot System, the slope of the closing curve for APCO Automatic Control Check Valves can be easily adapted to suit individual requirements.

Certified Flow Tested

Figures shown above are based on certified flow tests conducted at Utah State University, Water Research Laboratory, Report No. 299, Valves 8" & 14" (203 & 356mm). Actual field conditions may vary from these curves.

Note: When comparing similar competitors published data, only use certified flow test data.

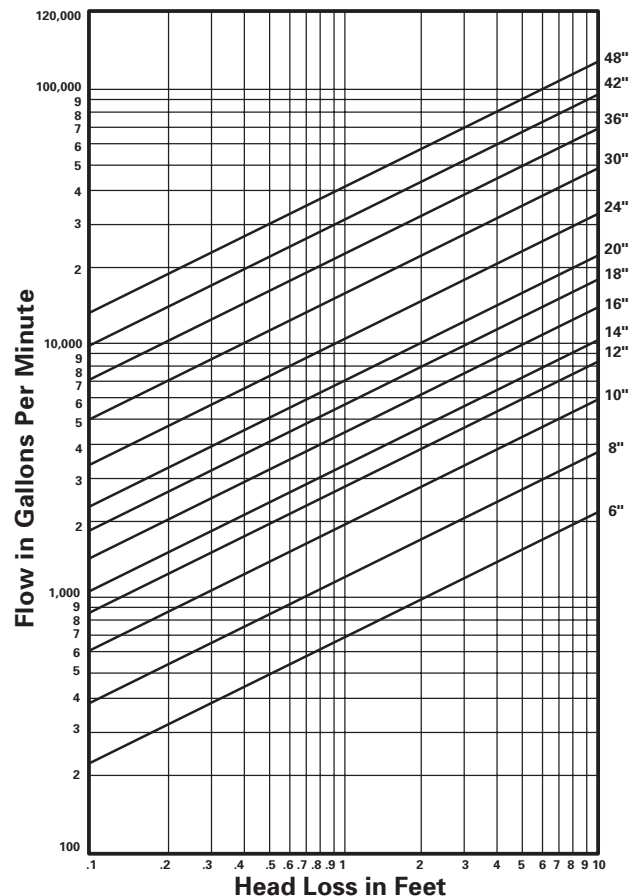

Specifications

Series 8000 Automatic Control Check Valve (ACCV) with Electric Motor Operator

The ACCV shall have an electric motor operator for normal opening and closing operation. When the ACCV is operating as a pump control valve, it shall allow the pump to come on line against a closed control valve, which will then be allowed to open slowly so as to eliminate system surge pressure at pump start. The valve shall be capable of closing against the running pump and then be able to signal the pump controls to turn off the pump motor. This feature will eliminate or minimize water hammer or pressure surge at pump shut down. The ACCV shall be capable of modulation service if equipped with an optional 4 to 20ma. control circuit feature.

The ACCV Pump Control Valve shall have a single "offset" pivoted disc above the centerline of the valve. This partially balanced design shall be capable of closing with minimal backflow and provide bubble tight shut-off. The valve shall have a non-slam closure feature without the need for any auxiliary power source supply, solenoid valves, or (oil, water or air) accumulator system. The offset pivot disc shall require minimal seating and unseating torques to prevent seat wear. The disc seat ring shall be bolted onto the disc, not welded, for ease of replacement in the field.

The ACCV shall be equipped with an electric motor driven power opening feature with a gear arrangement to provide for opening the valve against the down stream pressure to drain the line when desired.

The ACCV shall have a full flow area, designed to operate as a positive shut-off, throttling and/or check valve. The ACCV shall be controlled through a lost motion type of gear arrangement that is mounted on the side of the valve, totally enclosed in a lubricated gearbox. When operating as a check or throttling valve, the opening and closing speeds shall be controlled hydraulically by means of an oil dashpot system with speed control valves. This system shall be connected to the lost motion gear system and provide an independent adjustment of the opening and closing speeds.

The ACCV must be fail-safe during any electrical power failure, and the disc shall close hydraulically, energized only by the flow reversal in the line. The time of this disc closure shall be adjustable from 3 seconds to 45 seconds, by means of a cam operated (dump type) timing valve, permitting instant first stage closure to any degree, and then the hydraulic dashpot allows the second and third stage control towards final closure.

The ACCV body shall be of two (2) piece design, bolted together in a manner to capture the seat and be of an enlarged globe style through the disc section to create a 100% flow area to minimize head loss. The body shall have a built-in stop to positively prevent the disc from over-traveling the shutoff position. The body seat and disc ring must be hand replaceable in the field without the need for special tools, machining, or the need for removing the complete valve from the line. The seat material shall be precision molded Buna-N, reinforced with a heavy steel insert collar.

The valve shaft shall be of one-piece Type 17-4PH stainless steel material and extend completely through the valve disc and into the gearbox. (Not stub shafts)

Valve exterior shall be painted with a high build, corrosion resistant, alkyd resin primer, which is suitable for use in USDA, inspected facilities.

A computerized valve cavitation analysis will be required upon the engineer's request.

Sales and Service

For information about our worldwide locations, approvals, certifications and local representative:

Web Site: www.dezurik.com E-Mail: info@dezurik.com



250 Riverside Ave. N. Sartell, Minnesota 56377 • Phone: 320-259-2000 • Fax: 320-259-2227

DeZURIK, Inc. reserves the right to incorporate our latest design and material changes without notice or obligation. Design features, materials of construction and dimensional data, as described in this bulletin, are provided for your information only and should not be relied upon unless confirmed in writing by DeZURIK, Inc. Certified drawings are available upon request.