

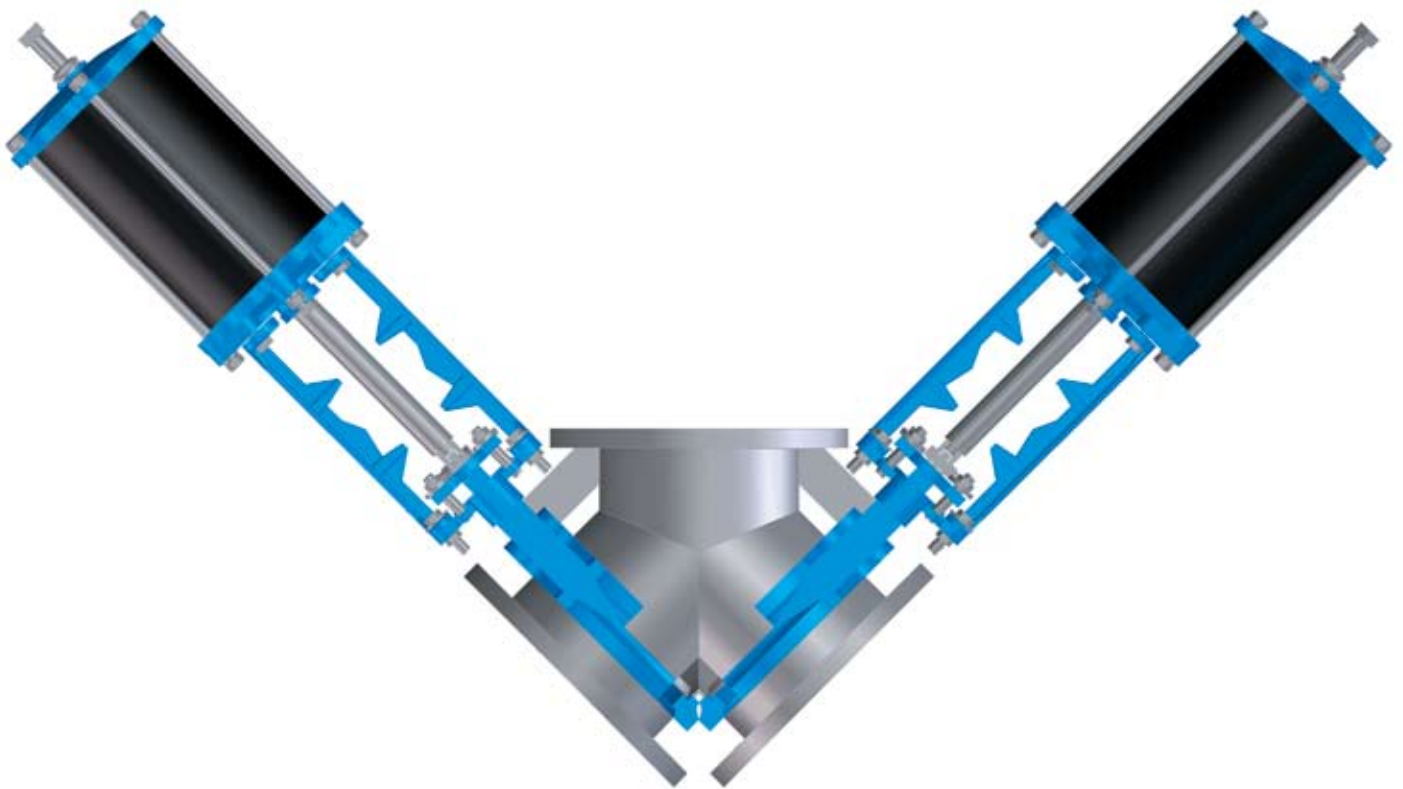

MIXING & DIVERTING KNIFE GATE VALVES



Variety of Configurations Available

DeZURIK Knife Gate Mixing & Diverting Valves are offered in a wide variety of patterns and sizes to meet the needs of dry material handling applications. Diverters in one inlet: 2-outlet, 3-outlet and 4-outlet configurations are available in True-Y pattern arrangements; one inlet: 2-outlet configurations are available in Y-Lateral arrangements. Mixing Valves are available with one outlet and 2, 3 or 4 inlets.

Quality Valve Construction

DeZURIK Mixing and Diverting Valves utilize the proven KGC Knife Gate Valves which offer stainless steel construction and wetted parts. Gates can be ordered with special treatments and special materials to withstand abrasion.

Integral Body Design

Standard configurations include an integral body design (shown on the cover) that minimizes pockets where buildup can accumulate. These multi-port diverter valves are integrally mounted to Y-pattern pipe to minimize dead space where material can accumulate (refer to seat illustration). This design

helps avoid product contamination by ensuring material is fully flushed from the pipe chamber.

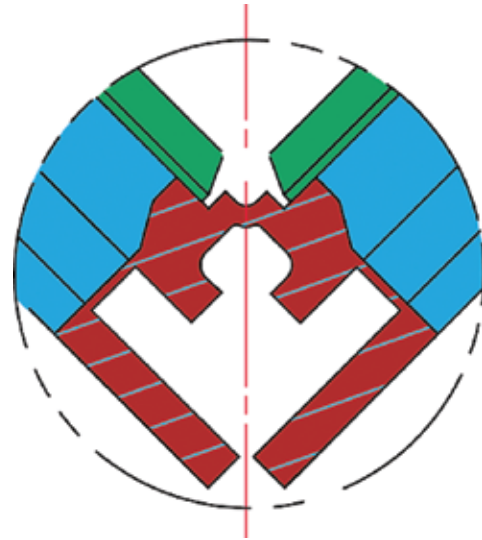

The seat area of the integral body design minimizes pockets where material can accumulate. Illustration above shows direct flow configuration. Reverse flow options are available.

Matching Port Diameters

DeZURIK can match the pipe schedule of the Y or Lateral chamber to coincide with the inside port diameters of the pipeline.

Replaceable Body Design

The replaceable body design features valves that are bolted to the Y-pattern pipe, allowing easy replacement of a single valve in the event of valve failure. As standard, Class 125/150 flange drillings are available.

The Replaceable Body Design allows individual valves to be easily replaced.

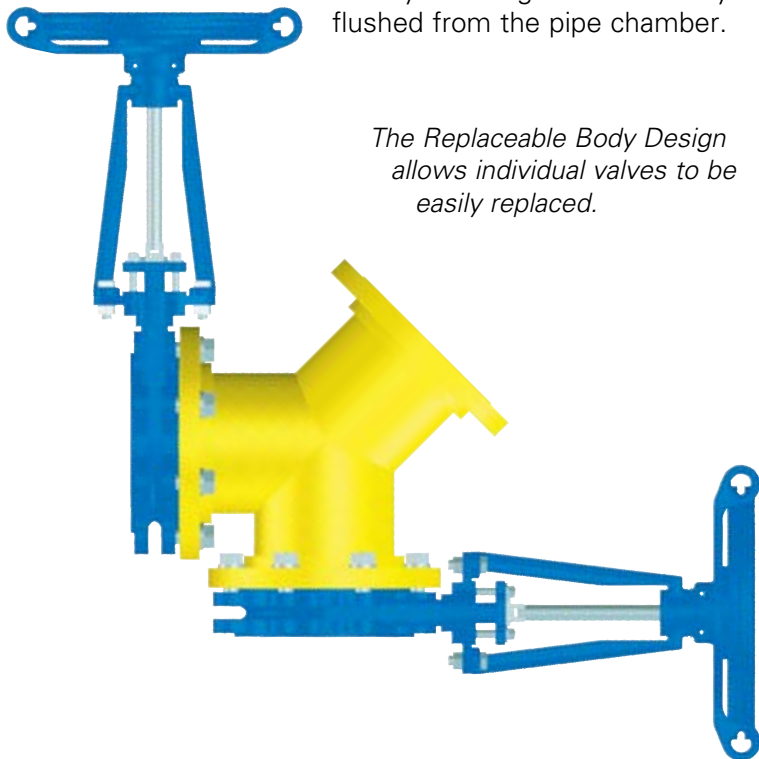

Y-Pattern or Lateral Configurations

Y-Pattern configurations with 60 or 90 degree angled valves, and Lateral configurations with 30 or 60 degree angled valves are offered as standard arrangements.

Custom Engineered Configurations

With over 40 years experience in designing and constructing knife gate mixing and diverting valves, DeZURIK has a large variety of custom-engineered options to meet a wide range of special applications. Contract DeZURIK regarding custom-designed configurations.

Purge Connections

To facilitate the removal of product from the dead space at the time of actuation, purge ports can be offered in the chest and seat area of the valves.

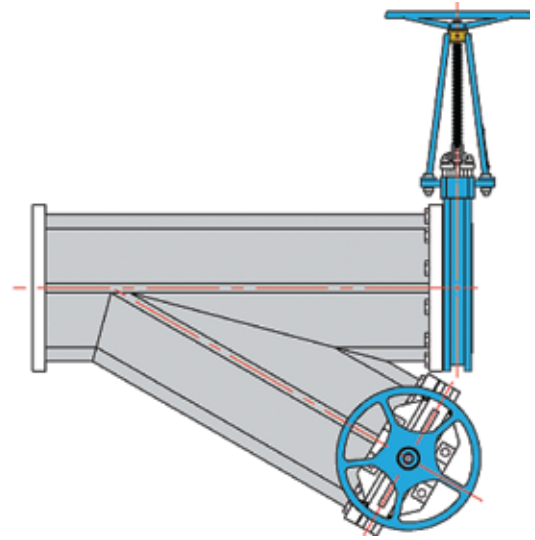

The lateral configuration, with 30 or 60 degree angled valves, are available as standard. Other arrangements can be custom engineered.

Direct & Reverse Flow Options

Valves can be mounted in Y or Lateral configurations for either direct or reverse flow service.

Actuator & Accessory Options

Handwheel, bevel gear, pneumatic cylinder and spring-return operators are available. In addition, a wide variety of accessories and options are also available.

Ordering

To order a Knife Gate Mixing and Diverting Valve, specify the following information:

1. Mating pipe/tube ID and thickness.
2. Y or Lateral angles other than STD.
3. Material for Y or Lateral if different than body material.
4. Give any special dimensions needed (DeZURIK's standard is to configure to use minimal space).
5. Actuator and accessory requirements.

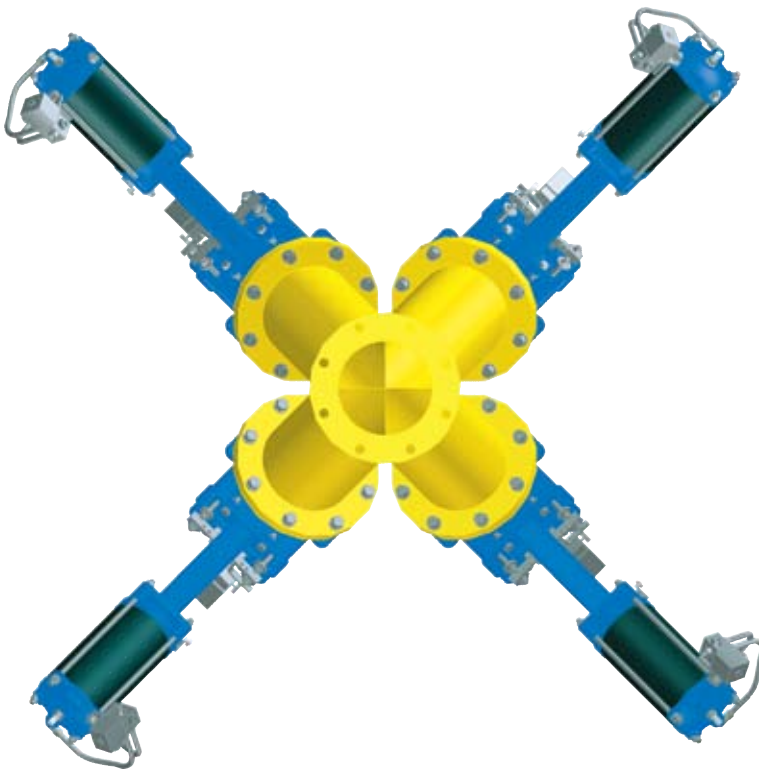

Diverter valves with one inlet and four outlets are available in True-Y pattern arrangements.

Ordering

To order, simply complete the valve order code from information shown. An ordering example is shown for your reference.

Valve Style

Give body style code as follows:

KG Y = Y or Lateral Gate Valve

Valve Size

Give size code as follows:

2 = 2" (50mm)	12 = 12" (300mm)
3 = 3" (80mm)	14 = 14" (350mm)
4 = 4" (100mm)	16 = 16" (400mm)
5 = 5" (125mm)	18 = 18" (450mm)
6 = 6" (150mm)	20 = 20" (500mm)
8 = 8" (200mm)	24 = 24" (600mm)
10 = 10" (250mm)	

Body Style

Give body style code as follows:

W60 = True Y 60°
W90 = True Y 90°
L30 = Y Lateral 30°
L60 = Y Lateral 60°

End Connections

Give end connection code as follows:

F1R = Flanged ANSI 150 Replaceable
F1I = Flanged ANSI 150 Integral

Outlets

Give outlets code as follows:

2 = 2 Outlets
3 = 3 Outlets (W only)
4 = 4 Outlets (W only)

Body Material

Give body material code as follows:

S1 = 304 Stainless Steel
S2 = 316 Stainless Steel
S3 = 317 Stainless Steel

Ordering Examples:

KG Y,8,L30,F1R,3,S1,TDP, S1-CR*Actuator
KG Y,8,W90,F1R,3,S2,TDP,S2-M*Actuator

Packing Material

Give packing material code as follows:

All packing systems (except HTP, HMP, MSP and FGP) come with glass filled PTFE anti-extrusion ring. High temperature packing system (HTP) has carbon graphite fiber composite anti-extrusion ring. FGP, MSP and HMP options do not have an anti-extrusion ring in packing system.

Standard Packing

MSP = Standard General Service Packaging to 500°F (260°C)
SMP = Standard Moderate Service Packaging to 500°F (260°C)

Optional Packings

ASP = Severe Service with Aflas Rubber Cord to 400°F (204°C)
TDP = Dry Service with PTFE Cord to 500°F (260°C)
HTP = High Temperature Braided Packing to 650°F (343°C)
HMP = High Temperature Braided Packing with Metal Scraper to 1000°F (540°C)
FGP = Food Grade Packing to 450°F (233°C)

Note: The limiting factor in valve selection is the lowest temperature of the packing or seat.

Gate Material

Give gate material code as follows:

S1 = 304 Stainless Steel
S2 = 316 Stainless Steel
S3 = 317 Stainless Steel
S5 = Hardened 17-4 PH Stainless Steel (H900)

Seat Material

Give seat material code as follows:

Note: All seat materials "except m" must use end connection F1R only

Standard

M = Integral Metal Seat (same as body material)
CR = Chloroprene to 180°F (83°C)
NBR = Acrylonitrile-Butadiene to 180°F (83°C)
EPDM = Terpolymer of Ethylene, Propylene and a Diene to 250°F (122°C)
FKM = Fluoro Rubber to 400°F (204°C)
CRW = Chloroprene, Off-White to 140°F (60°C)
CIIR = Chloro-Isobutene Isoprene 250°F (122°C)

Standard Options

Give options as follows:

PSA = Purge Ports in Seat Area (Replaceable bodies only)
PCA = Purge Ports in Chest Area
PSC = Purge Ports in Seat and Chest Area

Sales and Service

For information about our worldwide locations, approvals, certifications and local representative:

Web Site: www.dezurik.com E-Mail: info@dezurik.com



250 Riverside Ave. N. Sartell, Minnesota 56377 • Phone: 320-259-2000 • Fax: 320-259-2227

DeZURIK reserves the right to incorporate our latest design and material changes without notice or obligation. Design features, materials of construction and dimensional data, as described in this bulletin, are provided for your information only and should not be relied upon unless confirmed in writing by DeZURIK. Certified drawings are available upon request.