



HILTON COOLING WATER ISOLATION VALVE AT NASA ROCKET TEST FACILITY



John C. Stennis Space Center is a NASA test facility located in Mississippi that is responsible for overseeing the safe operation rocket engine propulsion test programs. During testing of rocket engines, temperatures on the test stand are high enough to melt the steel and destroy the concrete structure of the stand. Therefore, during testing, the test stand is flooded with water to lower the temperature on the stand. A 66" pipeline feeds water to the A-1 test stand which is capable of static firing a test article up to 33 feet in diameter. It has a maximum dynamic load of 1.7M pounds-force (lbf). The A-1 test stand was used most recently to test the Space Launch System (SLS) RS-25 rocket engine.

A 66" Hilton bonneted knife gate valve is used for cooling water isolation in the pipeline. Hilton was able to modify a standard 66" bonneted knife gate valve design and make changes to suit the application.

The cooling water isolation valve is only required to open at 25 psi maximum pressure differential and there is normally no pressure for the valve to open or close against. The pipeline is designed to handle a pressure of 275 psi, therefore the valve body is designed for the full pressure rating of 275 psi with a test pressure of 413 psi.

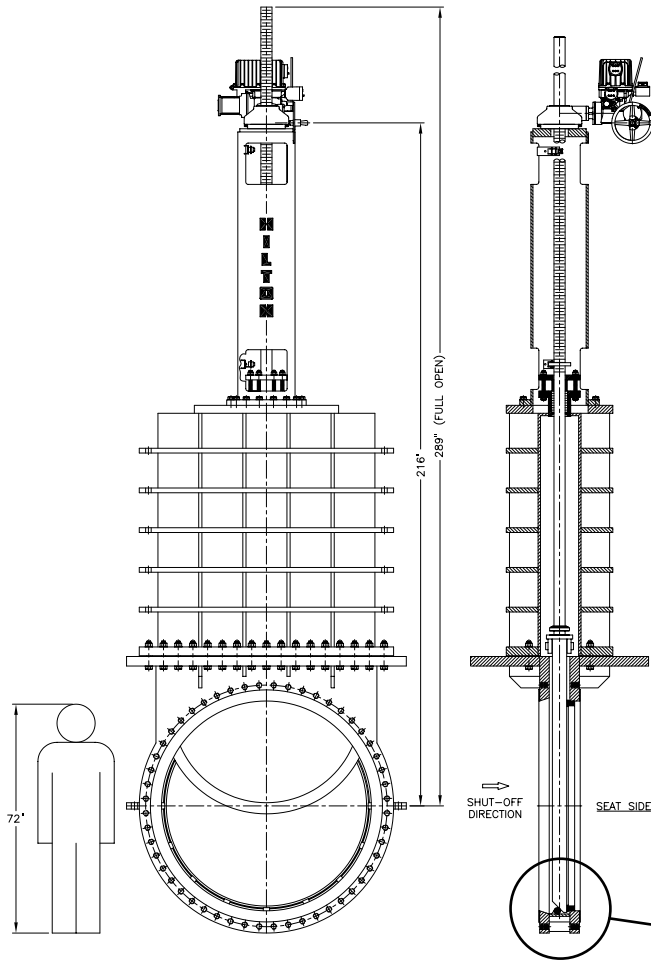

Because the valve body needs to withstand high design pressures, but the operating pressures are low and the valve is operated infrequently, a carbon steel gate with a 304 stainless steel gate seat is used to save material cost. The gate seat is a thin 304 stainless steel ring welded to the face of the carbon steel gate which allows the gate to be epoxy coated. The corrosion resistant 304 stainless steel gate seat makes contact with the 304 stainless steel body seat to seal flow. Except for the stainless interior components (gate ring, seat & stem) the balance of the valve is epoxy coated which also saves cost.

The motor is required to operate only at the 25 psi differential pressure, hence the small sized operator depicted in the picture and drawing.

Starting with Hilton's standard knife gate designs, many modifications can be made based on the application requirements. Click the following link to see a video test of the Space Launch System (SLS) RS-25 rocket engine at NASA's Stennis Space Center: https://www.youtube.com/watch?v=08Gv7qDxgUE&feature=player_detailpage

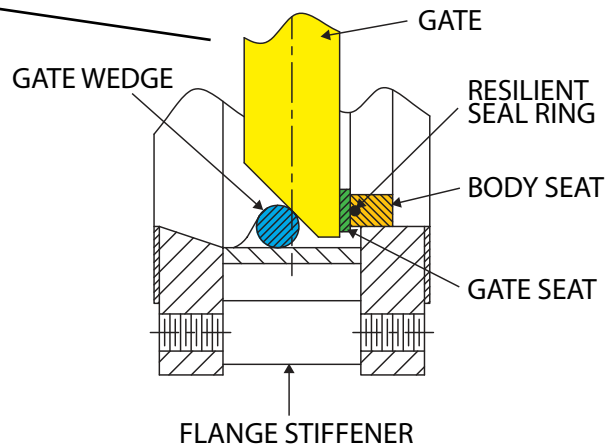

Sales and Service

For information about our worldwide locations, approvals, certifications and local representative:

Web Site: www.dezurik.com E-Mail: info@dezurik.com

Hilton Valve Direct Line: 425-883-7000



250 Riverside Ave. N. Sartell, Minnesota 56377 • Phone: 320-259-2000 • Fax: 320-259-2227

DeZURIK, Inc. reserves the right to incorporate our latest design and material changes without notice or obligation. Design features, materials of construction and dimensional data, as described in this bulletin, are provided for your information only and should not be relied upon unless confirmed in writing by DeZURIK, Inc. Certified drawings are available upon request.