

# DEZURIK MODELS 145 AND 250 DIAPHRAGM ACTUATOR ISO MOUNTING

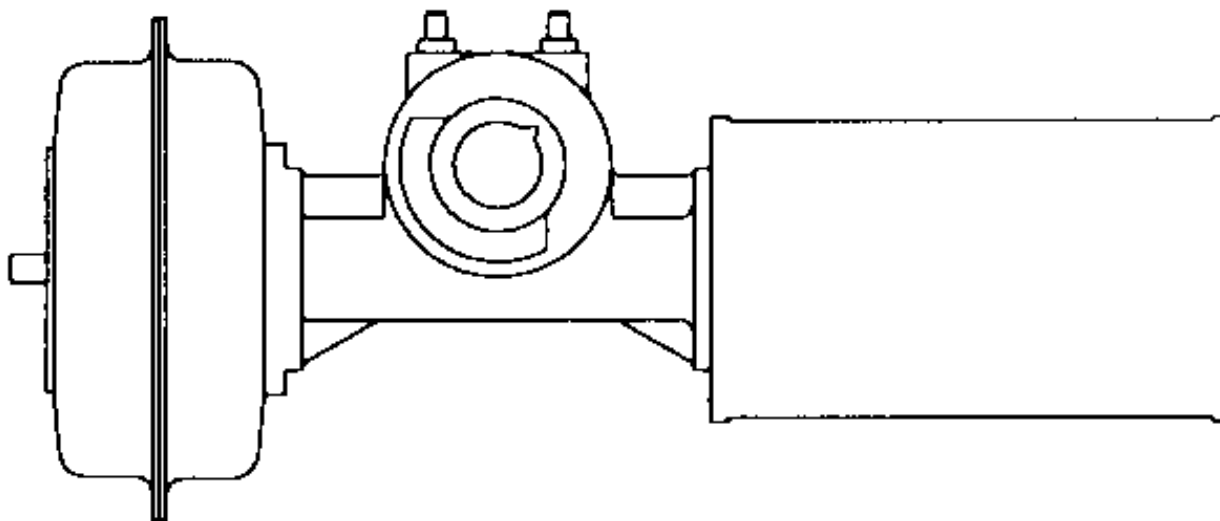

Instruction D10368  
September 2015

# DeZURIK

## DeZURIK MODELS 145 AND 250 DIAPHRAGM ACTUATOR ISO MOUNTING

---

### Instructions

These instructions provide information Model 145 and 250 Diaphragm actuators with ISO mounting.

### Safety Messages

All safety messages in the instructions are flagged with an exclamation symbol and the word **Caution**, **Warning** or **Danger**. These messages indicate procedures that must be followed exactly to avoid equipment damage, personal injury, or death.

Safety label(s) on the product indicate hazards that can cause equipment damage, personal injury, or death. If a safety label becomes difficult to see or read, or if a label has been removed, please contact DeZURIK for replacement label(s).



#### **WARNING!**

**Personnel involved in the installation or maintenance of valves should be constantly alert to potential emission of pipeline material and take appropriate safety precautions. Always wear suitable protection when dealing with hazardous pipeline materials. Handle valves, which have been removed from service with suitable protection for any potential pipeline material in the valve.**

---

### Inspection

Your Model 145 and 250 diaphragm actuator has been packaged to provide protection during shipment; however, it can be damaged in transport. Carefully inspect the unit for damage upon arrival and file a claim with the carrier if damage is apparent.

### Parts

Recommended spare parts are listed on the assembly drawing. These parts should be stocked to minimize downtime.

Order parts from your local DeZURIK sales representative, or directly from DeZURIK. When ordering parts, please include the 7-digit part number and 4-digit revision number (example: **9999999R000**) located on the data plate attached to the valve assembly. Also include the part name, the assembly drawing number, the balloon number and the quantity stated on the assembly drawing.

### DeZURIK Service

DeZURIK service personnel are available to install, maintain and repair all DeZURIK products. DeZURIK also offers customized training programs and consultation services.

For more information, contact your local DeZURIK sales representative or visit our website at [www.dezurik.com](http://www.dezurik.com).

**Table of Contents**

Description - - - - -	4
Installation - - - - -	4
Operation - - - - -	4
Lubrication - - - - -	4
Open and Closed Position Stops - - - - -	4
Spring Pre-Compression - - - - -	5
Diaphragm Replacement - - - - -	5
Removing Actuator from Valve - - - - -	7
Replacing Actuator on Valve - - - - -	7
Actuator Disassembly - - - - -	8
Actuator Assembly - - - - -	8
Reversing Actuator Action - - - - -	10
Changing Actuator Mounting Position on Valve - - - - -	12
Troubleshooting - - - - -	12

# DeZURIK

## DeZURIK MODELS 145 AND 250 DIAPHRAGM ACTUATOR ISO MOUNTING

---

### Description

The DeZURIK Model 145 or 250 Diaphragm Actuator is a pneumatic rack-and-gear spring-return rotary actuator used for on-off or modulating control. The actuator is used on a quarter-turn valve with an ISO actuator mounting configuration. The Model number-145 or 250-is the actuator size, and designates the effective pressure area in square inches of the spring-loaded diaphragm. The spring action may be spring-to-close or spring-to-open, and is reversible without additional parts. A choice of three spring ranges is available-20, 35 or 60 PSI (140, 240 or 420 kPa).

### Installation

One pneumatic signal line connection is required to the ½” NPT port on the end of the actuator. The pneumatic signal pressure must equal – but not exceed by more than 10 PSI (70 kPa)-the spring rating of zero to 20, 35 or 60 PSI (140, 240 or 420 kPa) as shown on the actuator label.

For high vibration installations, additional mounting support is recommended on the spring end of the actuator to prevent damage to the actuator and/or the piping system. Mount the support from the pipeline to the end of the spring cartridge.

### Operation

The actuator is powered pneumatically, and rotates 90 degrees between the open and closed positions. The action of the actuator is either spring-to-close or spring-to-open, as determined by the orientation of the diaphragm and the spring cartridge, as shown in Figure 1. The action selected is shown on the actuator label. With spring-to-close, increasing signal pressure to the actuator opens the valve, and decreasing pressure closes the valve; with spring-to-open, increasing pressure closes the valve, and decreasing pressure opens the valve.

### Lubrication

The actuator is lubricated at the factory and does not require routine maintenance.

### Open and Closed Position Stops

The open and closed position stops are the two hex head cap screws (B23) shown in Figure 1. The stops are adjustable and prevent the actuator from rotating beyond the open and closed positions of the valve. If the actuator is factory-mounted on the valve the stops are preset and do not require further adjustment. If the actuator is not mounted on the valve or if the actuator is removed and/or disassembled, the stops will require adjustment as described below. Refer to the Valve Instructions for the closed position requirements and adjust the stops with the actuator mounted on the valve. Refer to Figure 1 for component identification.

For **closed** stop adjustment on spring-to-**close** actuators or **open** stop adjustment on spring-to-**open** actuators:

1. Relieve the air pressure to the actuator.
2. Loosen the jam nut (B24) on the appropriate stop screw (B23). Refer to Figure 1.
3. Turn the stop screw in or out until the valve is in the correct position. The screw will turn easier if air pressure-just enough to relieve the force on the screw-is applied to the actuator. Relieve the pressure to check the stop screw adjustment.
4. Hold the stop screw from turning and tighten the jam nut to 230 ± 30 foot pounds (312 ± 41 Nm) if carbon steel or to 140 ± 18 foot pounds (190 ± 24 Nm) if stainless steel.

## Open and Closed Position Stops *(continued)*

For **closed** stop adjustment on spring-to-**open** actuators, or **open** stop adjustment on spring-to-**close** actuators:

1. Apply-but do not exceed-the maximum air pressure to the actuator as determined by the spring rating shown on the actuator label.
2. Loosen the jam nut (B24) on the appropriate stop screw (B23). Refer to Figure 1.
3. Turn the stop screw in or out until the valve is in the correct position. The screw will turn easier if the air pressure to the actuator is reduced. Reapply the maximum pressure in step 1 above to check the stop screw adjustment.
4. Hold the stop screw from turning and tighten the jam nut to  $230 \pm 30$  foot pounds ( $312 \pm 41$  Nm) if carbon steel or to  $140 \pm 18$  foot pounds ( $190 \pm 24$  Nm) if stainless steel.
5. Relieve the air pressure to the actuator.

## Spring Pre-Compression

Pre-compression in the 20 PSI and 35 PSI (140 kPa and 240 kPa) springs only is adjustable. The springs are factory set so that air pressure of 5 PSI (35 kPa) less than the spring rating will just open the valve for spring-to-close or will just close the valve for spring-to-open. Pre-compression in 60 PSI (420 kPa) springs is not adjustable. Pre-compression settings in a 20 PSI or 35 PSI (140 kPa and 240 kPa) spring may be adjusted several PSI (kPa) by following the steps below. Refer to Figure 1 for component identification.

1. Loosen the jam nut on the screw on the end of the spring cartridge (B8).
2. Turn the screw clockwise to increase the pre-compression; turn the screw counterclockwise to decrease the pre-compression.
3. Hold the screw from turning and tighten the jam nut to  $340 \pm 45$  foot pounds ( $460 \pm 60$  Nm).

## Diaphragm Replacement

Refer to Figure 1 for component identification.

1. Relieve the air pressure and disconnect the air line from the actuator. The actuator spring will open (for spring-to-open) or close (for spring-to-close) the valve.
2. Remove the diaphragm cover screws (B15), nuts (B16) and washers (B42); remove the diaphragm cover (B11) and diaphragm (B14).
3. Place the new diaphragm in position on the lower diaphragm cover (B12). Align the holes in the diaphragm with the holes in the cover.
4. Place the diaphragm cover (B11) in position on the diaphragm. Align the holes in the cover with the holes in the diaphragm and in the lower diaphragm cover.
5. Replace the cover screws (B15), nuts (B16) and washers (B42) in the holes and tighten all the screws evenly until the diaphragm is in contact with both covers, then tighten the screws in a crisscross pattern to  $12 \pm 2$  foot pounds ( $16 \pm 3$  Nm) for the Model 145 or  $18 \pm 2$  foot pounds ( $24 \pm 3$  Nm) for the Model 250.
6. Reconnect the air line to the actuator. Service may be resumed.

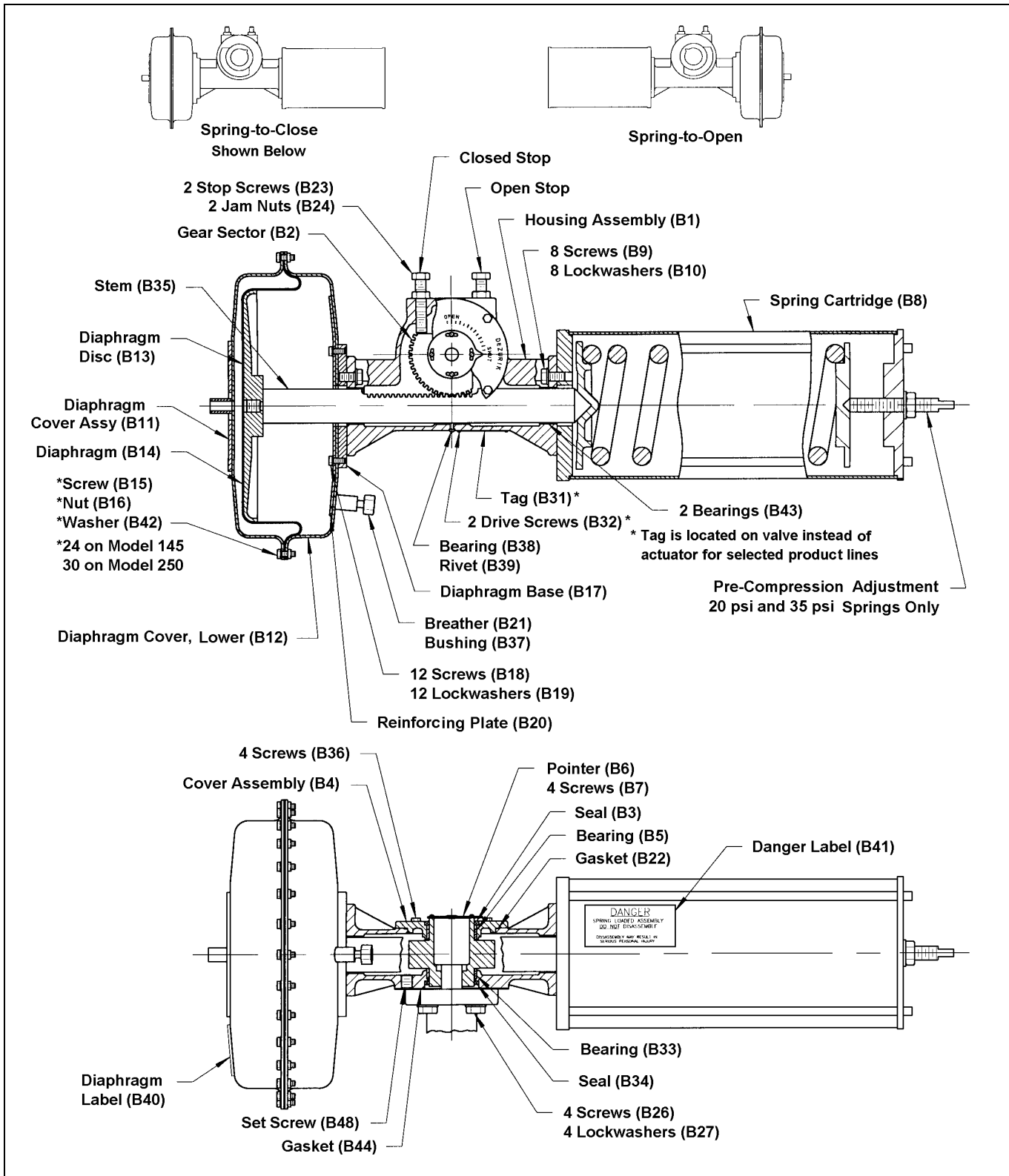

Figure 1-Parts Identification

## Removing Actuator From Valve

Refer to Figure 1 for component identification.

1. Shut down the flow in the pipeline.



### **WARNING!**

**Flow in the pipeline with the actuator removed can allow the valve to slam closed and cause personal injury and/or damage to the flow system. Shut down the flow in the pipeline before removing the actuator from the valve.**

---

2. Disconnect and lock out the pneumatic power to the actuator to prevent unexpected operation of the actuator.



### **WARNING!**

**Moving parts from unexpected operation of a powered actuator can cause personal injury or equipment damage. Disconnect and lock out power to the actuator before servicing.**

---

3. Remove the four actuator mounting screws (B26) and lockwashers (B27).
4. Lift and remove the actuator from the valve shaft. Retain the key for the valve shaft (A key is used only with round valve shafts).

## Replacing Actuator on Valve

Refer to Figure 1 for component identification.

1. Place the valve in the closed position for a spring-to-close actuator or in the open position for a spring-to-open actuator.
2. Select the desired mounting position for mounting the actuator on the valve. Refer to the optional positions shown on the Installation Drawing.
3. Certain high-temperature valves include and require a high-temperature gasket (B44). If the valve includes a gasket, use the gasket included with the valve rather than the gasket included with the actuator. Place the gasket between the actuator and the valve. Align the shaft hole in the gear sector (B2) with the valve shaft key and the valve shaft (A key is used only with a round valve shaft.) and slide the actuator onto the shaft and into position on the valve.
4. Fasten the actuator to the valve with the four mounting screws (B26) and lockwashers (B27). If the smaller bolt circle is used, tighten the M12 screws to  $83 \pm 10$  foot pounds ( $113 \pm 14$  Nm) if carbon steel or to  $58 \pm 8$  foot pounds ( $79 \pm 11$  Nm) if stainless steel; if larger bolt circle is used, tighten the M20 screws to  $435 \pm 60$  foot pounds ( $590 \pm 80$  Nm) if carbon steel, or to  $300 \pm 40$  foot pounds ( $400 \pm 50$  Nm) if stainless steel.
5. Reconnect all pneumatic and electrical connections.
6. Operate the valve to check the open and closed positions. Adjust the stops if necessary as described in the Open Closed Position Stops section.

### Actuator Disassembly

Refer to Figure 1 for component identification.

1. Remove the actuator from the valve as described in the *Removing the Actuator from Valve* section.
2. Apply just enough air pressure to the actuator to relieve the force on the stop bolts (B23) and back out both stop bolts several turns. Relieve the air pressure.
3. Remove the diaphragm cover screws (B15), nuts (B16), washers (B42), diaphragm cover (B11) and diaphragm (B14).
4. Remove the four pointer screws (B7) and the pointer (B6).
5. Remove the four cover screws (B36), the cover (B4) and the gasket (B22).
6. Carefully remove the diaphragm disc (B13) and stem (B35) from the housing assembly (B1). Do not scratch or damage the stem. To remove the disc from the stem, wrench on the last 1" (25mm) of the stem closest to the disc. The remainder of the stem is bearing surface and must remain free of wrench marks.
7. If replacing the lower diaphragm cover (B12), remove the screws (B18), lockwashers (B19), reinforcing plate (B20), lower diaphragm cover (B12), screws (B9), lockwashers (B10) and diaphragm base (B17).
8. If relocating or replacing the spring cartridge (B8), remove the screws (B9), lockwashers (B10) and the spring cartridge from the housing assembly (B1). **Do not disassemble the spring assembly.**



#### **WARNING!**

**The spring cartridge includes a compressed spring. Death or serious injury can result if the spring cartridge is disassembled.**

**DO NOT DISASSEMBLE THE SPRING CARTRIDGE**

---

### Actuator Assembly

Before assembling the actuator, clean and inspect all parts. Worn parts-especially seal and bearings-should be replaced. Refer to Figure 1 for component identification and orientation. Note that the diaphragm, spring cartridge and gear sector positions depend upon whether the actuator action is spring-to-close or spring-to-open.

1. If the spring cartridge (B8) was removed, mount the spring cartridge to the housing assembly with screws (B9) and lockwashers (B10). Tighten the screws to  $180 \pm 20$  foot pounds ( $244 \pm 27$  Nm).
2. If the lower diaphragm cover (B12) and diaphragm base (B17) were removed, mount the diaphragm base to the housing assembly (B1) with screws (B9) and lockwashers (B10). Tighten the screws to  $180 \pm 20$  foot pounds ( $244 \pm 27$  Nm). Then mount the lower diaphragm cover (B12) and reinforcing plate (B20) to the diaphragm base (B17) with screws (B18) and lockwashers (B19). Tighten the screws to  $26 \pm 3$  foot pounds ( $35 \pm 4$  Nm).
3. If the diaphragm disc (B13) was removed from the stem (B35), carefully thread the stem into the disc. Wrench on the last 1" (25 mm) of the stem closest to the disc, and tighten to  $200 \pm 10$  foot pounds ( $270 \pm 14$  Nm). The remainder of the stem is a bearing surface, and must remain free of wrench marks and scratches.



**Actuator Assembly (continued)**

4. Carefully insert the stem (B35) into the housing assembly (B1) with the teeth facing the gear sector (B2) position.
5. Apply a paint-like coating of lubricant to the teeth and bearing hubs of the gear sector (B2) and to the teeth of the stem (B35) using one of these lubricants:
  - Keystone Zeniplex-1 (**recommended**)
  - Amoco Amolith Grease #1-EP (alternate)
  - Amsoil GHD (alternate)
  - Mobil Mobilux EP 1 (alternate)
  - Shell Alvania EP 1 (alternate)
  - Texaco Multifak EP 1 (alternate)

**Note:** Do not get grease on the bearing surfaces of the stem or on the three stem bearings.

6. Note that the stem (B35) has one tooth with a punch mark, and the gear sector (B2) has two pair of teeth with punch marks. The one marked tooth in the stem must mesh between the pair of marked teeth that will provide 90° of gear sector rotation as the stem moves in the direction of the air stroke. The spring-to-close and spring-to-open configurations are shown in Figure 1. Accordingly, place the gear sector in position in the housing assembly (B1).
7. Mount the cover (B4) and gasket (B22) to the housing assembly (B1) with the four cover screws (B36). Tighten the screws to 26 ± 3 foot pounds (35 ± 4 Nm).
8. Mount the pointer (B6) to the gear sector (B2) with the four screws (B7). Tighten the screws to 18 ± 2 *inch* pounds (2.0 ± 0.2 Nm).
9. Place the diaphragm (B14) in position on the lower diaphragm cover (B12). Align the holes in the diaphragm with the holes in the cover.
10. Place the diaphragm cover (B11) in position on the diaphragm. Align the holes in the cover with the holes in the diaphragm and in the lower diaphragm cover.
11. Assemble the cover screws (B15), nuts (B16) and washers (B42) in the holes, and tighten all the screws evenly until the diaphragm is in contact with both covers. Then tighten the screws in a crisscross pattern to 12 ± 2 foot pounds (16 ± 3 Nm) for the Model 145, or to 18 ± 2 foot pounds (24 ± 3 Nm) for the Model 250.

### Reversing Actuator Action

Follow the steps below to change the actuator from spring-to-close to spring-to-open or vice versa. Refer to Figure 1 for component identification.

1. Remove the actuator from the valve as described in the *Removing the Actuator from Valve* section.
  2. Apply just enough air pressure to the actuator to relieve the force on the stop bolts (B23) and back out both stop bolts several turns. Relieve the air pressure.
  3. Remove the diaphragm cover screws (B15), nuts (B16), washers (B42), diaphragm cover (B11) and diaphragm (B14).
  4. Remove the four pointer screws (B7) and the pointer (B6).
  5. Remove the four cover screws (B36), the cover (B4) and the gasket (B22).
  6. Carefully remove the diaphragm disc (B13) and stem (B35) from the housing assembly (B1). Do not scratch or damage the stem.
  7. Remove the four screws (B9) and lockwashers (B10) and remove the lower diaphragm cover (B12), reinforcing plate (B20) and diaphragm base (B17) assembly from the housing (B1).
  8. Remove the four screws (B9) and lockwashers (B10) and remove the spring cartridge (B8) from the housing assembly (B1). **Do not disassemble the spring assembly.**
- 



#### **WARNING!**

**The spring cartridge includes a compressed spring. Death or serious injury can result if the spring cartridge is disassembled.**

#### **DO NOT DISASSEMBLE THE SPRING CARTRIDGE**

---

11. Mount the spring cartridge (B8) to the housing assembly end opposite of where it was removed with screws (B9) and lockwashers (B10). Tighten the screws to  $180 \pm 20$  foot pounds ( $244 \pm 27$  Nm).
12. Mount the lower diaphragm cover (B12), reinforcing plate (B20), and diaphragm base (B17) assembly to the housing assembly (B1) with screws (B9) and lockwashers (B10) opposite the spring cartridge (B8). Tighten the screws to  $180 \pm 20$  foot pounds ( $244 \pm 27$  Nm).
13. Carefully insert the stem (B35) into the housing assembly (B1) with the teeth facing the gear sector (B2) position.
14. Apply a paint-like coating of lubricant to the teeth and bearing hubs of the gear sector (B2) and to the teeth of the stem (B35) using one of these lubricants:
  - Keystone Zeniplex-1 (**recommended**)
  - Amoco Amolith Grease #1-EP (alternate)
  - Amsoil GHD (alternate)
  - Mobil Mobilux EP 1 (alternate)
  - Shell Alvania EP 1 (alternate)
  - Texaco Multifak EP 1 (alternate)

**Note:** Do not get grease on the bearing surfaces of the stem or on the three stem bearings.

**Reversing Actuator Action** *(continued)*

15. Note that the stem (B35) has one tooth with a punch mark, and the gear sector (B2) has two pair of teeth with punch marks. The one marked tooth in the stem must mesh between the pair of marked teeth that will provide 90° of gear sector rotation as the stem moves in the direction of the air stroke. The spring-to-close and spring-to-open configurations are shown in Figure 1. Accordingly, place the gear sector in position in the housing assembly (B1).
16. Mount the cover (B4) and gasket (B22) to the housing assembly (B1) with the four cover screws (B36). Tighten the screws to  $26 \pm 3$  foot pounds ( $35 \pm 4$  Nm).
17. Mount the pointer (B6) to the gear sector (B2) with the four screws (B7). Tighten the screws to  $18 \pm 2$  inch pounds ( $2.0 \pm 0.2$  Nm).
18. Place the diaphragm (B14) in position on the lower diaphragm cover (B12). Align the holes in the diaphragm with the holes in the cover.
19. Place the diaphragm cover (B11) in position on the diaphragm. Align the holes in the cover with the holes in the diaphragm and in the lower diaphragm cover.
20. Assemble the cover screws (B15), nuts (B16) and washers (B42) in the holes, and tighten all the screws evenly until the diaphragm is in contact with both covers. Then tighten the screws in a crisscross pattern to  $12 \pm 2$  foot pounds ( $16 \pm 3$  Nm) for the Model 145, or to  $18 \pm 2$  foot pounds ( $24 \pm 3$  Nm) for the Model 250.
21. Replace the actuator on the valve as described in the *Replacing Actuator on Valve* section.

## Changing Actuator Mounting Position on Valve

Before changing the actuator mounting position, check to assure that clearance is available for the proposed actuator location. The actuator may be mounted on the valve in either of two positions—standard or 180°—both perpendicular with the pipeline, as shown on the installation drawing. To change the position, follow steps in the *Removing Actuator from Valve* section and the *Replacing Actuator on Valve* section.

## Troubleshooting

Condition	Possible Cause	Corrective Action
Actuator will not operate valve.	Rubber diaphragm is ruptured.	Replace diaphragm. See <i>Diaphragm Replacement</i> section.
Actuator closes to wrong position.	Closed position stop is set incorrectly.	Adjust closed position stop. See <i>Open and Closed Position Stops</i> section.
Actuator opens to wrong position.	Open position stop is set incorrectly.	Adjust open position stop. See <i>Open and Closed Position Stops</i> section.
Actuator will not fully operate valve.	Actuator air pressure is low.	Increase air pressure. Do not exceed spring rating.
	Actuator is sized incorrectly.	Use spring with increased rating, or use larger actuator.
	Pipeline obstruction in valve is preventing closure.	Remove obstruction.
Spring operates valve in wrong direction.	Spring-to-close should be spring-to-open, or vice versa	Reverse the action. See <i>Reversing Actuator Action</i> section.
Actuator operation is not smooth; movement is “jerky”.	Stem bearings are worn.	Replace stem bearings (B43) and (B38). See <i>Actuator Disassembly</i> and <i>Actuator Assembly</i> sections.
	Stem is worn.	Replace stem (B3). See <i>Actuator Disassembly</i> and <i>Actuator Assembly</i> sections.

## Limited Warranty

DeZURIK, Inc. ("Seller") manufactured products, auxiliaries and parts for a period of twenty-four (24) months from date of shipment from Seller's factory, are warranted to the original purchaser only against defective workmanship and material, but only if properly stored, installed, operated, and serviced in accordance with Seller's recommendations and instructions.

For items proven to be defective within the warranty period, your exclusive remedy under this limited warranty is repair or replacement of the defective item, at Seller's option, FCA Incoterms 2020 Seller's facility with removal, transportation, and installation at your cost.

Products or parts manufactured by others but furnished by Seller are not covered by this limited warranty. Seller will provide repair or replacement for other's products or parts only to the extent provided in and honored by the original manufacturer's warranty to Seller, in each case subject to the limitations contained in the original manufacturer's warranty.

No claim for transportation, labor, or special or consequential damages or any other loss, cost or damage is being provided in this limited warranty. You shall be solely responsible for determining suitability for use and in no event shall Seller be liable in this respect.

This limited warranty does not warrant that any Seller product or part is resistant to corrosion, erosion, abrasion or other sources of failure, nor does Seller warrant a minimum length of service.

Your failure to give written notice to us of any alleged defect under this warranty within twenty (20) days of its discovery, or attempts by someone other than Seller or its authorized representatives to remedy the alleged defects therein, or failure to return product or parts for repair or replacement as herein provided, or failure to store, install, or operate said products and parts according to the recommendations and instructions furnished by Seller shall be a waiver by you of all rights under this limited warranty.

This limited warranty is voided by any misuse, modification, abuse or alteration of Seller's product, accident, fire, flood or other Act of God, or your failure to pay entire contract price when due.

The foregoing limited warranty shall be null and void if, after shipment from our factory, the item is modified in any way or a component of another manufacturer, such as but not limited to, an actuator is attached to the item by anyone other than a Seller factory authorized service personnel.

All orders accepted shall be deemed accepted subject to this limited warranty, which shall be exclusive of any other or previous Warranty, and this shall be the only effective guarantee or warranty binding on Seller, despite anything to the contrary contained in the purchase order or represented by any agent or employee of Seller in writing or otherwise, notwithstanding, including but not limited to implied warranties.

THE FOREGOING REPAIR AND REPLACEMENT LIMITED WARRANTY IS IN LIEU OF ALL OTHER WARRANTIES, OBLIGATIONS AND LIABILITIES, INCLUDING ALL WARRANTIES OF FITNESS FOR A PARTICULAR PURPOSE OR OF MERCHANTABILITY OR OTHERWISE, EXPRESSED OR IMPLIED IN FACT OR BY LAW, AND STATE SELLER'S ENTIRE AND EXCLUSIVE LIABILITY AND YOUR EXCLUSIVE REMEDY FOR ANY CLAIM IN CONNECTION WITH THE SALE AND FURNISHING OF SERVICES, GOODS OR PARTS, THEIR DESIGN, SUITABILITY FOR USE, INSTALLATION OR OPERATIONS.

## Disclaimer

Metric fasteners should not be used with ASME Class 150/300 bolt holes and flange bolt patterns. If you use metric fasteners with ASME Class 150/300 bolt holes and flange bolt patterns, it may lead to product failure, injury, and loss of life. DeZURIK Inc. disclaims all liability associated with the use of metric fasteners with ASME Class 150/300 bolt holes and flange patterns, including but not limited to personal injury, loss of life, loss of product, production time, equipment, property damage, lost profits, consequential damages of any kind and environment damage and/or cleanup. Use of metric fasteners with ASME Class 150/300 bolt holes and flange bolt patterns is a misuse that voids all warranties and contractual assurances. If you use metric fasteners with ASME Class 150/300 bolt holes and flange bolt patterns, you do so at your sole risk and any liability associated with such use shall not be the responsibility of DeZURIK, Inc. In addition to the foregoing, DeZURIK's Manufacturer's Conditions apply.

## Limitation of Liability

IN NO EVENT SHALL SELLER BE LIABLE FOR ANY DIRECT, INDIRECT, SPECIAL, PUNITIVE, OR CONSEQUENTIAL DAMAGES WHATSOEVER, AND SELLER'S LIABILITY, UNDER NO CIRCUMSTANCES, WILL EXCEED THE CONTRACT PRICE FOR THE GOODS AND/OR SERVICES FOR WHICH LIABILITY IS CLAIMED. ANY ACTION FOR BREACH OF CONTRACT BY YOU, OTHER THAN RIGHTS RESPECTING OUR LIMITED WARRANTY DESCRIBED ABOVE, MUST BE COMMENCED WITHIN 12 MONTHS AFTER THE DATE OF SALE.

## Sales and Service

For information about our worldwide locations, approvals, certifications and local representative:

Web site: [www.dezurik.com](http://www.dezurik.com) E-Mail: [info@dezurik.com](mailto:info@dezurik.com)



250 Riverside Ave. N., Sartell, MN 56377 • Phone: 320-259-2000 • Fax: 320-259-2227

*DeZURIK, Inc. reserves the right to incorporate our latest design and material changes without notice or obligation. Design features, materials of construction and dimensional data, as described in this manual, are provided for your information only and should not be relied upon unless confirmed in writing by DeZURIK, Inc. Certified drawings are available upon request.*