

# DEZURIK DR-85B ROTARY DIAPHRAGM ACTUATOR

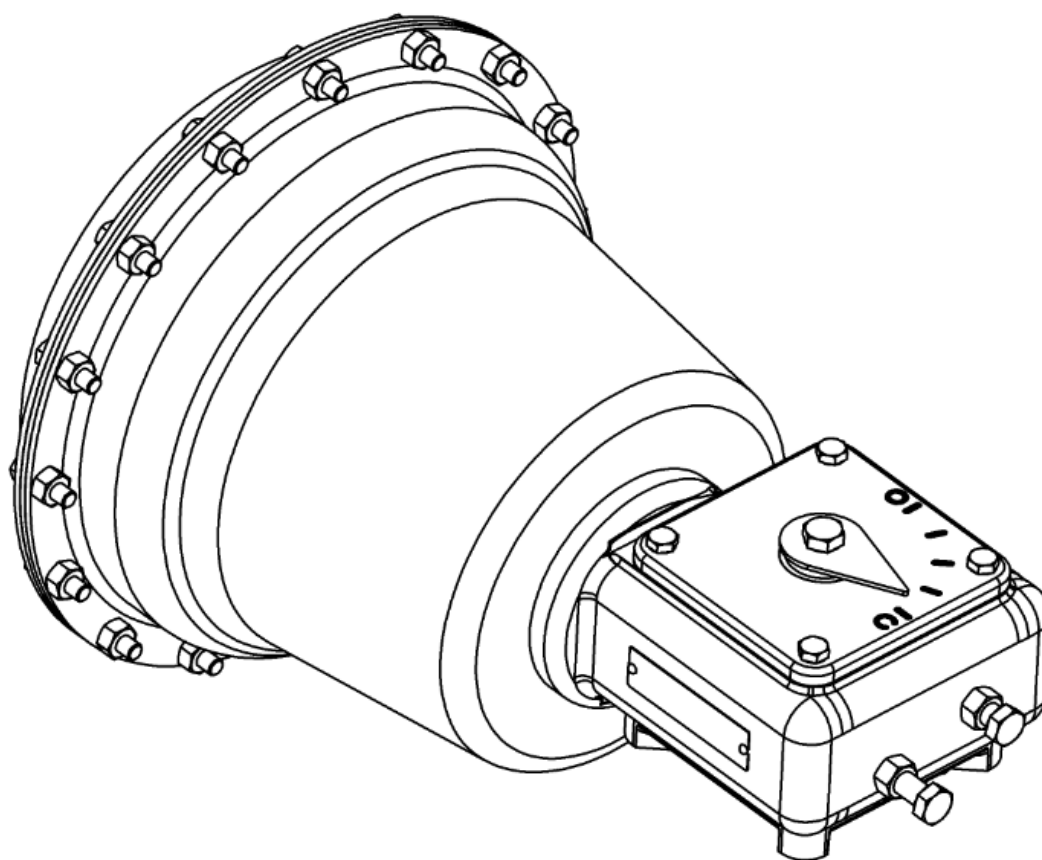

Instruction **D10512**  
February 2020

### Instructions

These instructions provide information about the DR-85B Rotary Diaphragm Actuator. They are for use by personnel who are responsible for installation, operation and maintenance of DR Model 85B Diaphragm Actuators.

### Safety Messages

All safety messages in the instructions are identified by a general warning sign and the signal word CAUTION, WARNING or DANGER. These messages indicate procedures that must be followed exactly to avoid equipment damage, personal injury or death. Safety label(s) on the product indicate hazards that can cause injury or death.

If a safety label becomes difficult to see or read, or if a label has been removed, please contact DeZURIK for replacement label(s).

---

#### **▲ WARNING**

**Personnel involved in the installation or maintenance of valves should be constantly alert to potential emission of pipeline material and take appropriate safety precautions. Always wear suitable protection when dealing with hazardous pipeline materials. Handle valves, which have been removed from service with suitable protection for any potential pipeline material in the valve.**

---

### Inspection

Your DR-85B Rotary Diaphragm Actuator has been packaged to provide protection during shipment, however, it can be damaged in transport. Carefully inspect the unit for damage upon arrival and file a claim with the carrier if damage is apparent.

### Parts

Recommended spare parts are listed on the assembly drawing. These parts should be stocked to minimize downtime.

Order parts from your DeZURIK sales representative, or directly from DeZURIK. When ordering parts, please include the 7-digit part number and 4-digit revision number (example: **9999999R000**) or serial number located on the data plate attached to the valve assembly. Also include the part name, the assembly drawing number, the balloon number and the quantity stated on the assembly drawing.

### DeZURIK Service

DeZURIK service personnel are available to install, maintain and repair all DeZURIK products. DeZURIK also offers customized training programs and consultation services.

For more information, contact your local DeZURIK sales representative or visit our website at [www.dezurik.com](http://www.dezurik.com)

### Disposal

Your Rotary Diaphragm Actuator contains a permanently compressed spring assembly. Prior to disposal of the actuator or spring assembly, the spring pressure must be relieved. See Actuator Disposal section for complete instructions.

## Table of Contents

Description.....	4
Installation .....	4
Operation.....	4
Lubrication .....	4
Parts Identification.....	5
Open and Closed Position Stops.....	7
Removing Actuator from Valve .....	8
Replacing Actuator on Valve .....	8
Spring Assembly Replacement.....	10
Diaphragm Replacement.....	12
Reversing the Diaphragm Action .....	12
Changing Actuator Mounting Position On Valve.....	14
Lockable Model .....	14
Spring-to-Open Actuator .....	14
Spring-to-Close Actuator.....	14
Unlocked Condition .....	15
Locked Fail Position .....	16
Locked Powered Position .....	16
Actuator Disposal .....	17
Troubleshooting.....	18

# DeZURIK

## DR-85B Rotary Diaphragm Actuator

---

### Description

The DR-85B Rotary Diaphragm Actuator is a pneumatic spring-return rotary actuator used for on-off or modulating control of a quarter-turn valve. The model number—85—is the actuator size, and designates the effective pressure area in square inches of the spring-loaded diaphragm. The spring action may be spring-to-close or spring-to-open, and is reversible without additional parts.

A choice of two spring ranges is available—35 or 60 psi (240 or 410 kPa). A lockable model of the actuator is available. Operation of the lockable model is described in the *Lockable Model* section.

### Installation

One pneumatic signal line connection is required to the ¼ NPT port on diaphragm cover (B1) shown in Figure 1. The pneumatic signal pressure must equal—but not exceed by more than 10 psi (70 kPa)—the spring rating of 35 or 60 psi (240 or 410 kPa) as shown on the actuator label.

For high vibration installations, additional mounting support is recommended on the diaphragm end of the actuator to prevent damage to the actuator and/or the piping system. Mount the support from the pipeline to at least two of the diaphragm cover screws (B2) shown in Figure 1. Tighten the screws to  $18 \pm 2$  foot pounds ( $24 \pm 3$  Nm).

### Operation

The actuator is powered pneumatically, and rotates 90 degrees between the open and closed positions. The action of the actuator is either spring-to-close or spring-to-open, as determined by which side of the actuator is mounted to the valve, as shown in Figure 1. The action selected is shown on the actuator label. With spring-to-close, increasing pressure to the actuator opens the valve, and decreasing pressure closes the valve; with spring-to-open, increasing pressure closes the valve, and decreasing pressure opens the valve.

### Lubrication

The actuator is lubricated at the factory, and does not require further lubrication.

# DeZURIK DR-85B Rotary Diaphragm Actuator

## Parts Identification

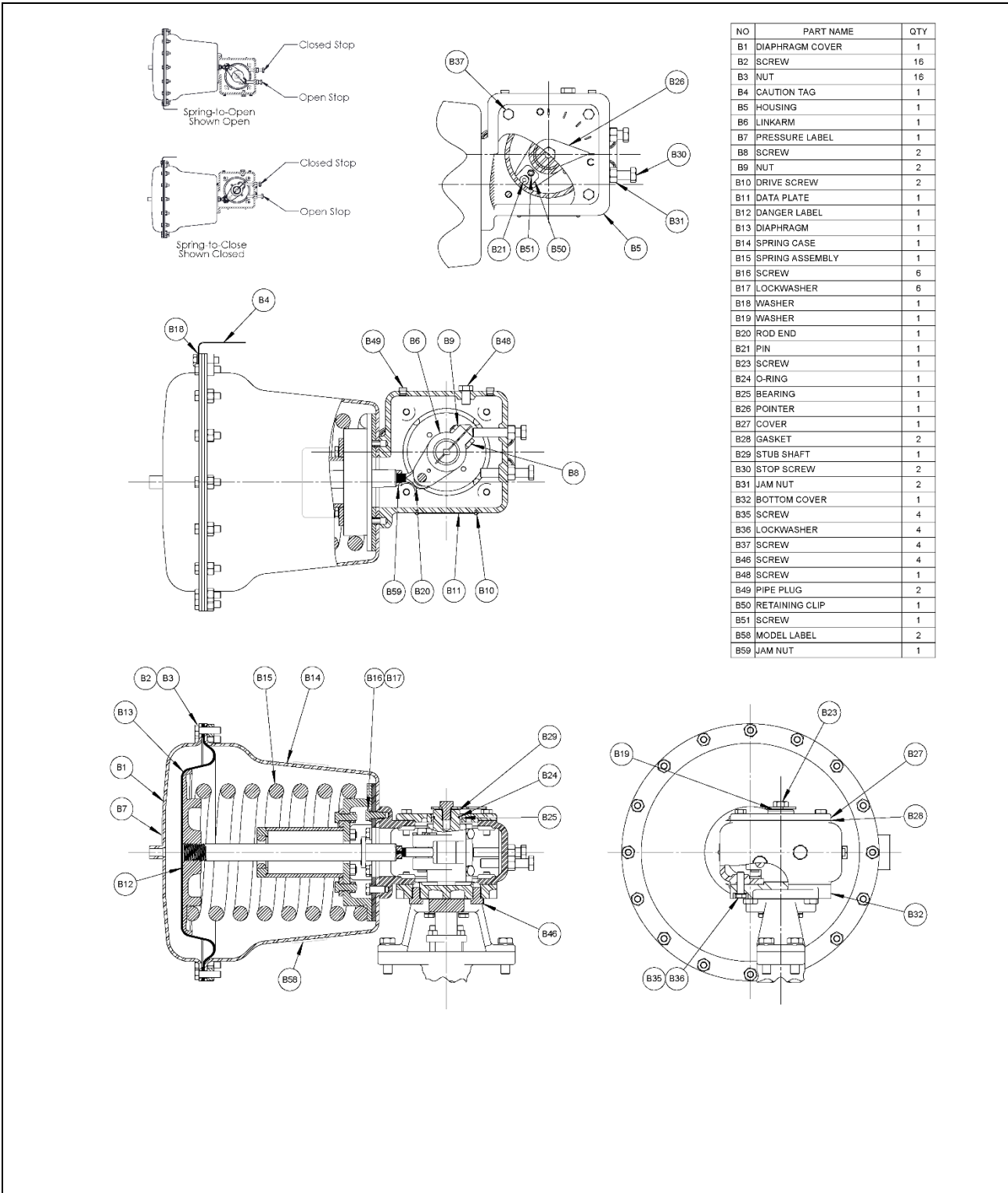
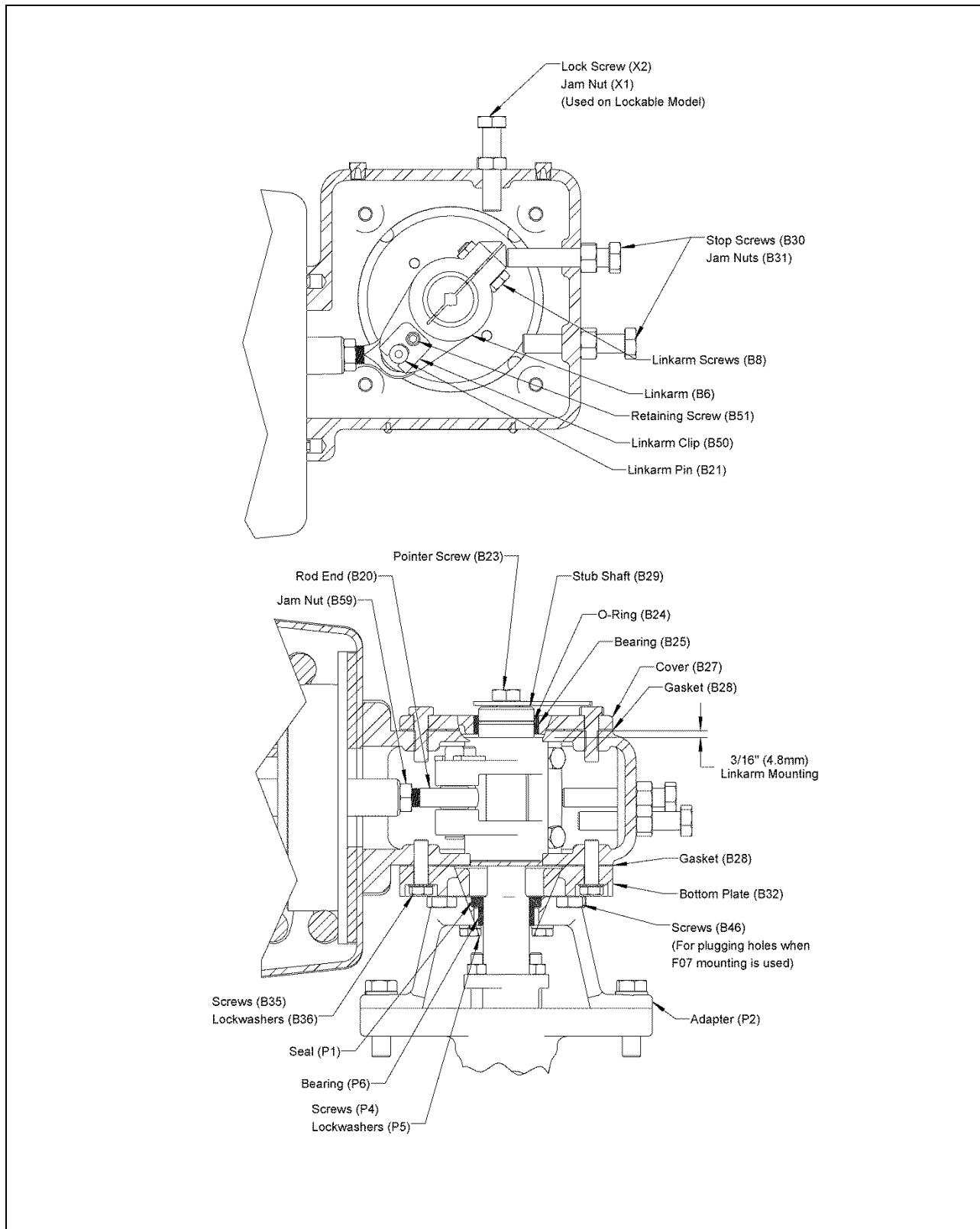

**Figure 1—Parts Identification**

# DeZURIK

## DR-85B Rotary Diaphragm Actuator

### Parts Identification *(continued)*



**Figure 1A—Parts Identification**

## Open and Closed Position Stops

The open and closed position stops are the two hex head screws (B30) shown in Figure 1. The stops are adjustable and prevent the actuator from rotating beyond the open and closed positions of the valve. If the actuator is factory-mounted on the valve, the stops are preset and do not require further adjustment.

If the actuator is not factory-mounted on the valve, or if the actuator is removed and/or disassembled, the stops will require adjustment as described below. Refer to the valve instructions for closed-position information, and adjust the stops with the actuator mounted on the valve. Refer to Figure 1 for component identification.

For **closed** stop adjustment on spring-to-**close** actuators, or **open** stop adjustment on spring-to-**open** actuators:

1. Relieve the air pressure to the actuator.
2. Loosen the jam nut (B31) on the appropriate stop screw (B30). Refer to Figure 1.
3. Turn the stop screw in or out until the valve is in the correct position. The screw will turn easier if air pressure—just enough to relieve the force on the screw—is applied to the actuator. Relieve the pressure to check the stop screw adjustment.
4. Hold the stop screw from turning, and tighten the jam nut to  $38 \pm 5$  foot pounds ( $52 \pm 7$  Nm).

For **closed** stop adjustment on spring-to-**open** actuators, or **open** stop adjustment on spring-to-**close** actuators:

1. Apply—but do not exceed—the maximum air pressure to the actuator, as determined by the spring rating shown on the actuator label.
2. Loosen the jam nut (B31) on the appropriate stop screw (B30). Refer to Figure 1.
3. Turn the stop screw in or out until the valve is in the correct position. The screw will turn easier if the air pressure to the actuator is reduced. Reapply the maximum pressure in step 1 above to check the stop screw adjustment.
4. Hold the stop screw from turning, and tighten the jam nut to  $38 \pm 5$  foot pounds ( $52 \pm 7$  Nm).
5. Relieve the air pressure to the actuator.

## Removing Actuator from Valve

Refer to Figure 1 and 1A for component identification.

1. Shut down the flow in the pipeline.

---

### **⚠ WARNING**

**Flow in the pipeline with the actuator removed can slam the valve closed causing personal injury and damaging the flow system. Shut down the flow in the pipeline before removing the actuator from the valve.**

---

2. Disconnect and lock out the pneumatic power to the actuator to prevent accidental operation of the actuator. Ensure that the actuator and pipeline are de-energized.

---

### **⚠ WARNING**

**Moving parts from unexpected operation of a powered actuator can cause personal injury or equipment damage. Disconnect and lock out power to the actuator before servicing.**

---

3. Remove the pointer screw (B23), pointer (B26), washer (B19), positioner and/or switches if so equipped, from the actuator.
4. Apply about 10 psi (70 kPa) air pressure to the actuator, and remove the four top cover screws (B37) and the top cover (B27). Removal or replacement of the top cover without pressure on the actuator is very difficult, and could cause damage to the actuator or valve.
5. Remove the retaining screw (B51) and linkarm clip (B50) from the link arm (B6). You can use the retaining screw (B51) to remove the linkarm pin (B21) by screwing into the top of the pin.
6. Relieve the air pressure to the actuator, and disconnect the actuator piping.
7. Loosen the two link arm screws (B8) and remove the link arm (B6) from the valve.
8. Remove the four actuator mounting screws (P4), and remove the actuator.

## Replacing Actuator on Valve

Refer to Figure 1 and 1A for component identification.

1. Place the valve in the closed position for a spring-to-close actuator, or in the open position for a spring-to-open actuator.
2. Select the desired mounting orientation for mounting the actuator on the valve. Refer to limitations in the Changing Actuator Mounting Position on Valve section.
3. Fasten the actuator to the valve adapter with the four mounting screws and lockwashers (P4 and P5). Tighten the screws as shown in Table A.
4. Align the shaft hole in the link arm (B6) with the valve shaft and slide the link arm onto the shaft.



**Replacing Actuator on Valve** *(continued)*

**Table A: Torque Requirements for Actuator Mounting Screws**

Screw Size	Carbon Steel Fasteners		Stainless Steel Fasteners	
	Foot Pounds	Newton Meters	Foot Pounds	Newton Meters
3/8-16	26 ± 3	35 ± 4	15 ± 2	20 ± 3
1/2-13	63 ± 8	85 ± 11	38 ± 5	52 ± 7
M8 X 1.25	23 ± 3	31 ± 4	16 ± 2	22 ± 3
M12 X 1.75	83 ± 10	113 ± 14	58 ± 8	79 ± 11

5. Position the link arm (B6) 3/16" (4.8 mm) below the top of the actuator as shown in Figure 1A. Tighten the two link arm screws (B8) to 38 ± 5 foot pounds (52 ± 7 Nm).
6. Connect the actuator piping. Apply air pressure so that the rod end (B20) is aligned between the holes in the link arm (B6). Insert the linkarm pin (B21) into the linkarm, retaining with the linkarm clip (B50) and retaining screw (B51).
7. Lubricate the o-ring (B24) with o-ring grease such as Dow Corning Molykote 55 o-ring grease. Position the o-ring (B24) in the groove in the stub shaft (B29), and mount the gasket (B28) and cover (B27) to the actuator with the four screws (B37). Tighten the screws to 38 ± 5 foot pounds (52 ± 7 Nm).
8. Relieve the air pressure to the actuator. Mount the pointer (B26) to the stub shaft (B29) with the screw (B23) and washer (B19) under the pointer. Tighten the screw to 38 ± 5 foot pounds (52 ± 7 Nm).
9. Re-mount any accessories that were removed, and connect all pneumatic and electrical connections.
10. Operate the valve to check the open and closed positions. Adjust the stops, if necessary, as described in the *Open and Closed Position Stops* section.

# DeZURIK

## DR-85B Rotary Diaphragm Actuator

---

### Spring Assembly Replacement

Refer to Figure 1 for parts identification.

---

#### **⚠ DANGER**

**This actuator includes a compressed spring. Death or serious injury can result if the spring cover is removed incorrectly.**

**FOLLOW THE INSTRUCTIONS CAREFULLY TO ENSURE SAFETY!**

---

1. Shut down the flow in the pipeline.

#### **⚠ WARNING**

**Flow in the pipeline with the actuator removed can slam the valve closed causing personal injury and damaging the flow system. Shut down the flow in the pipeline before removing the actuator from the valve.**

---

2. Disconnect and lock out the pneumatic power to the actuator to prevent accidental operation of the actuator. Ensure that the actuator and pipeline are de-energized.

#### **⚠ WARNING**

**Moving parts from unexpected operation of a powered actuator can cause personal injury or equipment damage. Disconnect and lock out power to the actuator before servicing.**

---

3. Remove the screw (B23), pointer (B26), and washer (B19).
4. Apply about 10 psi (70 kPa) air pressure to the actuator, and remove the four top cover screws (B33 on BHP Valves; B37 on others) and the top cover (B27). Removal or replacement of the top cover without pressure on the actuator is very difficult, and could cause damage to the actuator or valve.
5. Remove the retaining screw (B51) and linkarm clip (B50) from the link arm (B6). You can use the retaining screw (B51) to remove the linkarm pin (B21) by screwing into the top of the pin.
6. Relieve the air pressure to the actuator, and disconnect the actuator piping.
7. Remove three screws (B2), nuts (B3), and washers (B38) from the diaphragm cover (B1). The three screws removed must be equally spaced as shown in Figure 2.

## Spring Assembly Replacement (continued)

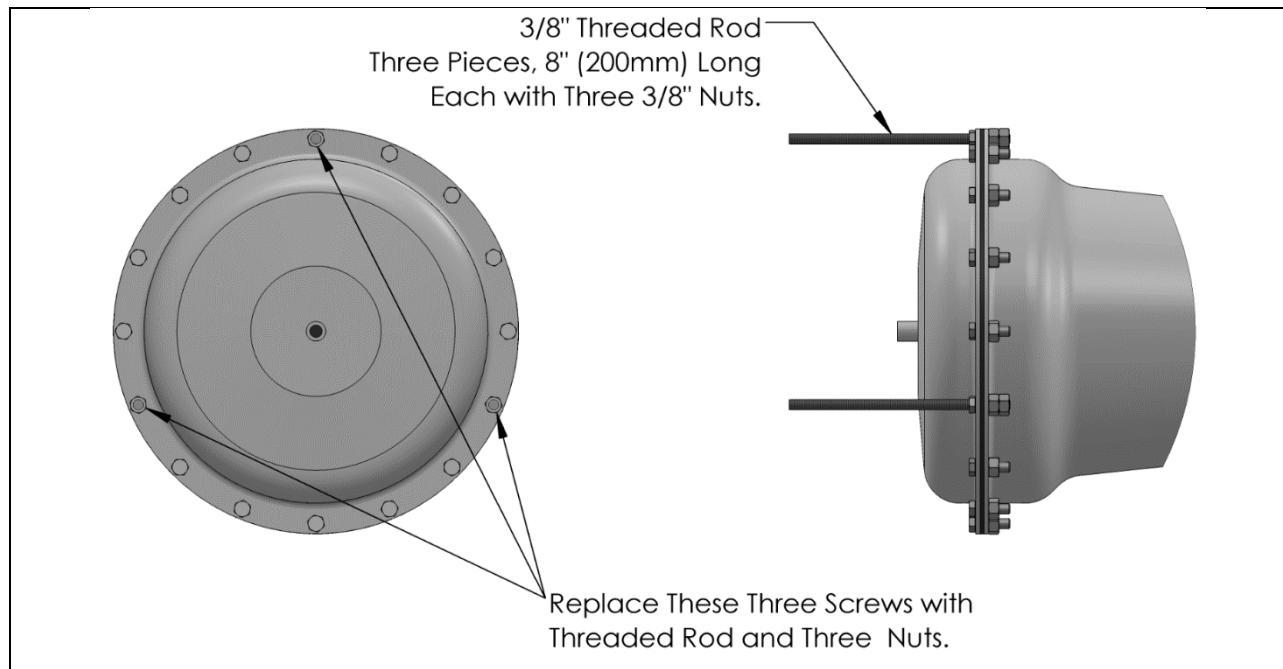

**Figure 2—Stud Requirements For Diaphragm Cover Removal**

8. Obtain three 3/8" diameter threaded rods, each at least 8" (200 mm) long, and nine 3/8" nuts. As shown in Figure 2, assemble one rod and three nuts in each of the holes from which the screws were removed in the previous step. Jam the double nuts together by tightening to  $26 \pm 3$  foot pounds ( $35 \pm 4$  Nm); tighten the single nuts finger tight against the cover.
9. Remove the remaining screws (B2), nuts (B3), and washers (B38) from the diaphragm cover (B1).
10. Turn the single nuts counterclockwise—carefully, evenly, and slowly—from each of the three threaded rods. Continue turning each nut until the spring force is fully relieved from the diaphragm cover (B1). Then remove the nuts, the threaded rods, and the diaphragm cover from the actuator.
11. Remove the rubber diaphragm (B13) from the spring case (B14).
12. Remove the spring assembly (B15) from the spring case (B14). Do not disassemble the spring assembly.

## **⚠ DANGER**

**The spring assembly includes a compressed spring. Death or serious injury can result if the spring is disassembled. DO NOT DISASSEMBLE THE SPRING ASSEMBLY!**

13. Loosen the jam nut (B59) and remove the rod end (B20) from the old spring assembly. Screw the rod end and jam nut into the new spring assembly so about 1/4" of thread remain showing above the jam nut.

# DeZURIK

## DR-85B Rotary Diaphragm Actuator

---

### Spring Assembly Replacement *(continued)*

14. Slide the new spring assembly (B15) into the spring case (B14) so that the two pins in the spring base fit into the two holes in the housing (B5).
15. Mount the diaphragm (B13) and the diaphragm cover (B1) to the spring case (B14) with screws (B2) and nuts (B3). Place the caution tag (B4) and washer (B38) under one of the screws. Tighten the screws evenly until the rubber diaphragm is in contact with the cover and the spring case. Then tighten the screws in a crisscross pattern to  $18 \pm 2$  foot pounds ( $24 \pm 3$  Nm).
16. Connect the actuator piping. Apply air pressure so that the rod end (B20) is aligned between the holes in the link arm (B6). Insert the linkarm pin (B21) into the linkarm, retaining with the linkarm clip (B50) and retaining screw (B51). Tighten the rod end jam nut (B59).
17. Lubricate the o-ring (B24) with o-ring grease such as Dow Corning Molykote 55 o-ring grease. Position the o-ring (B24) in the groove in the stub shaft (B29), and mount the gasket (B28) and cover (B27) to the actuator with the four screws (B37). Tighten the screws to  $38 \pm 5$  foot pounds ( $52 \pm 7$  Nm).
18. Relieve the air pressure to the actuator. Mount the pointer (B26) to the stub shaft (B29) with the screw (B23) and washer (B19) under the pointer. Tighten the screw to  $38 \pm 5$  foot pounds ( $52 \pm 7$  Nm).
19. Re-connect all pneumatic and electrical connections.
20. Operate the valve to check the open and closed positions. Adjust the stops, if necessary, as described in the Open and Closed Position Stops section.

### Diaphragm Replacement

The diaphragm may be replaced by following spring assembly replacement steps, 1 through 11 for disassembly, and then following steps 15 through 20 in the Spring Assembly Replacement section.

### Reversing the Diaphragm Action

Refer to Figure 1 and Figure 1A for parts identification.

1. Shut down the flow in the pipeline.

---

#### **⚠ WARNING**

**Flow in the pipeline with the actuator removed can slam the valve closed causing personal injury and damaging the flow system. Shut down the flow in the pipeline before removing the actuator from the valve.**

---

2. Disconnect and lock out the pneumatic power to the actuator to prevent accidental operation of the actuator. Ensure that the actuator and pipeline are de-energized.

---

#### **⚠ WARNING**

**Moving parts from unexpected operation of a powered actuator can cause personal injury or equipment damage. Disconnect and lock out power to the actuator before servicing.**

---

### **Reversing the Diaphragm Action** *(continued)*

3. Remove the pointer screw (B23), pointer (B26), and washer (B19) from the actuator.
4. Apply about 10 psi (70 kPa) air pressure to the actuator, and remove the four top cover screws (B37) and the top cover (B27). Removal or replacement of the top cover without pressure on the actuator is very difficult, and could cause damage to the actuator or valve.
5. Remove the retaining screw (B51) and linkarm clip (B50) from the link arm (B6). You can use the retaining screw (B51) to remove the linkarm pin (B21) by screwing into the top of the pin.
6. Relieve the air pressure to the actuator, and disconnect the actuator piping.
7. Loosen the two link arm screws (B8) and remove the stub shaft (B29) from the link arm (B6); remove the link arm from the valve shaft.
8. Remove the four actuator mounting screws (P4) and washers (P5), and remove the actuator.
9. Replace the link arm on the valve shaft in the appropriate position as shown in Figure 1.
10. Turn the actuator upside down, and re-mount the actuator to the adaptor with the same screws (P4) and washers (P5). Tighten the screws as shown in Table A.
11. Position the link arm (B6) 3/16" (4.8 mm) below the top of the actuator as shown in Figure 1.
12. Connect the actuator piping. Apply air pressure so that the rod end (B20) is aligned between the holes in the link arm (B6). Insert the linkarm pin (B21) into the linkarm, retaining with the linkarm clip (B50) and retaining screw (B51).
13. Tighten the two link arm screws (B8) to  $35 \pm 5$  foot pounds ( $47 \pm 7$  Nm).
14. Lubricate the o-ring (B24) with o-ring grease such as Dow Corning Molykote 55 o-ring grease. Position the o-ring (B24) in the groove in the stub shaft (B29), and mount the gasket (B28) and cover (B27) to the actuator with the four screws (B37). Tighten the screws to  $38 \pm 5$  foot pounds ( $52 \pm 7$  Nm).
15. Relieve the air pressure to the actuator. Mount the pointer (B26) to the stub shaft (B29) with the screw (B23) and washer (B19) under the pointer. Tighten the screw to  $38 \pm 5$  foot pounds ( $52 \pm 7$  Nm).
16. Re-mount any accessories that were removed, and connect all pneumatic and electrical connections.
17. Operate the valve to check the open and closed positions. Adjust the stops, if necessary, as described in the *Open and Closed Position Stops* section.

### Changing Actuator Mounting Position On Valve

Before changing the actuator mounting position, check to assure that pipeline flange clearance and room clearance is available for the proposed actuator location.

The actuator may be mounted on the valve in any of four mounting positions— standard, 90°, 180°, or 270°—as shown on the Installation Drawing. To change the mounting position, follow the steps in the *Removing Actuator from Valve* section and the *Replacing Actuator on Valve* section.

### Lockable Model

The DR-85B Rotary Diaphragm Actuator is available as a lockable model that allows the actuator to be locked in the open or closed position. The lockable model is identified by DRL in the catalog characteristic. The lockable spring-to-open actuator has three options—DF, DP, and DE; the lockable spring-to-close actuator has three comparable options—RF, RP, and RE. The six options are shown in Figure 3, and are described as follows:

#### ***Spring-to-Open Actuator***

- The DF option allows the actuator to be locked in the open (fail) position, and includes a lock screw (X2), jam nut (X1), and lockout cover assembly (X5).
- The DP option allows the actuator to be locked in the closed (powered) position, and includes a manual override and a lockable chain.
- The DE option allows the actuator to be locked in either the open or closed position, and includes the same items as options DF and DP together.

#### ***Spring-to-Close Actuator***

- The RF option allows the actuator to be locked in the closed (fail) position, and includes a lock screw (X2), jam nut (X1), and lockout cover assembly (X5).
- The RP option allows the actuator to be locked in the open (powered) position, and includes a manual override and a lockable chain.
- The RE option allows the actuator to be locked in either the open or closed position, and includes the same items as options RF and RP together.

**Lockable Model** (continued)

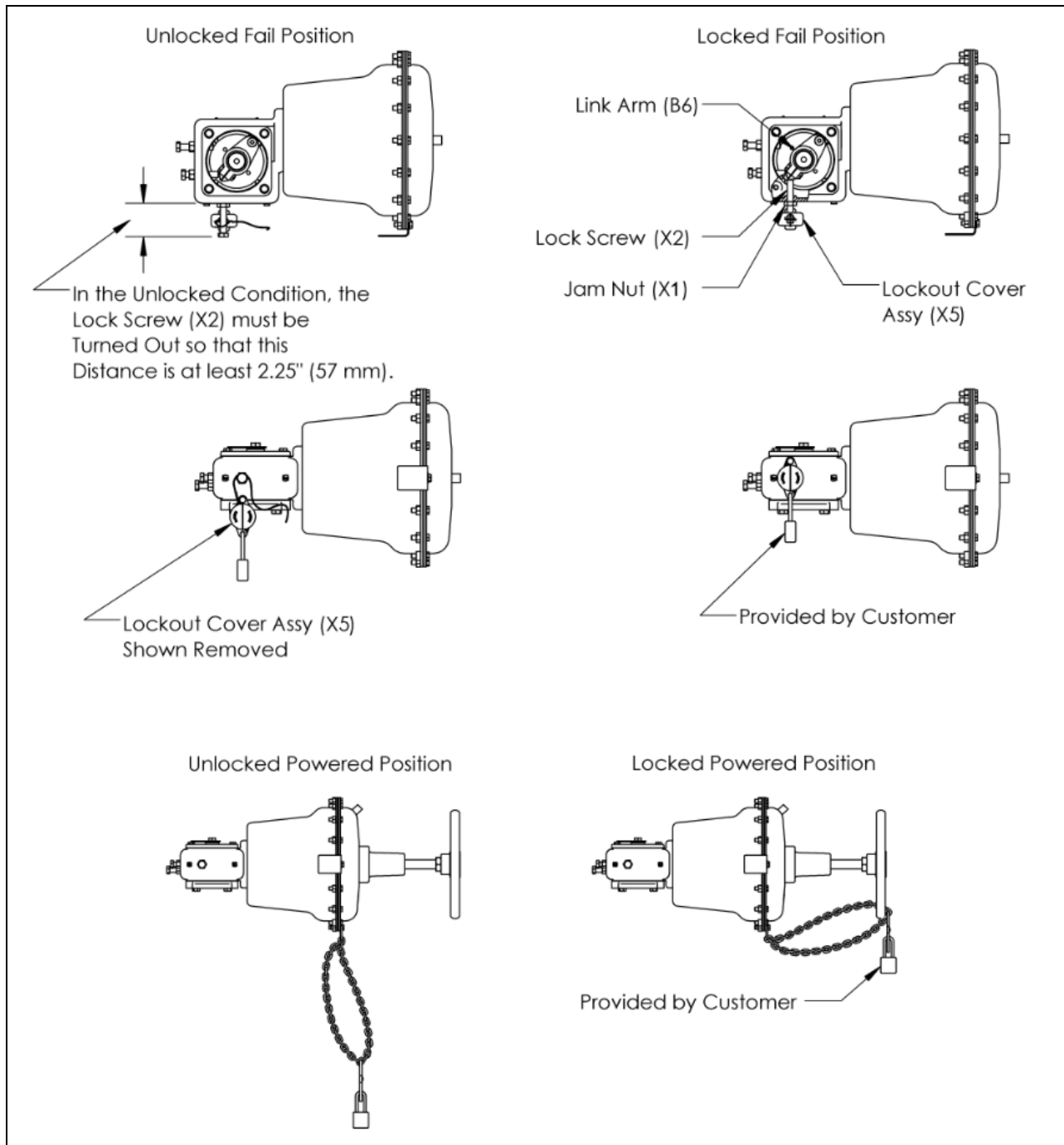

**Figure 3—Lockable Model, Component Identification**

**Unlocked Condition**

Under normal unlocked running conditions, the lockable features must be positioned away from the inside of the actuator so that the actuator stroke is limited only by the open and closed position stops as described in the *Open and Closed Position Stops* section.

The fail position of the actuator is lockable with the lock screw (B64) and jam nut (B65) as shown in Figure 3. In the unlocked position, the lock screw must be turned counterclockwise until the distance from the housing to the end of the lock screw is at least 2-1/4" (57 mm). To hold the lock screw in position, tighten the jam nut to  $77 \pm 10$  foot pounds ( $104 \pm 14$  Nm).

The powered position of the actuator is lockable with the manual override as shown in Figure 3. In the unlocked position, the manual override handwheel must be turned to the extreme counterclockwise position. To hold the handwheel in position, the chain may be fastened or locked to the handwheel.

### Locked Fail Position

Follow the steps below to change the unlocked condition to the locked fail position. Refer to Figure 3 for component identification. Before proceeding, the open and closed position stops must be correctly adjusted as described in the *Open and Closed Position Stops* section.

1. Relieve the air pressure to the actuator so that the actuator moves to the extreme fail position.
2. Hold the lock screw (B64) from turning, and loosen the jam nut (B65) several turns counterclockwise, to the head of the lock screw.
3. Turn the lock screw clockwise several turns until resistance is felt from the stop screw contacting the link arm (B6) inside the actuator. Tighten the lock screw to 5 to 10 foot pounds (7 to 14 Nm) to assure that the lock screw is contacting the link arm.
4. Turn the jam nut against the cover. While holding the lock screw from turning, tighten the jam nut to  $77 \pm 10$  foot pounds ( $140 \pm 14$  Nm).
5. Place and lock the lockout cover assembly (B60) on the head of the lock screw.

### Locked Powered Position

Follow the steps below to change the unlocked condition to the locked powered position. Refer to Figure 3 for component identification. Before proceeding, the open and closed position stops must be correctly adjusted as described in the *Open and Closed Position Stops* section.

1. Apply air pressure to the actuator so that the actuator moves to the extreme powered position.
2. Turn the handwheel clockwise several turns until resistance is felt, and apply torque so that the mechanism firmly contacts the inside the actuator.
3. Place and lock the chain between the spokes in the handwheel so that the chain will prevent the handwheel from being turned counterclockwise.



## Actuator Disposal

Remove the actuator from the valve by following the instructions described in the *Removing Actuator from Valve* section.

Before disposing of the actuator or spring assembly, the compressed spring pressure must be relieved. For this to be completed safely, the spring assembly must be contained within the spring housing. Use a cutting torch to cut through the housing in at least 2 locations (see Figure 4). Next, use the torch to cut through the spring coils in those locations. Check that all sections of the spring are loose within the housing before disposal, this will ensure that the actuator is completely de-energized.

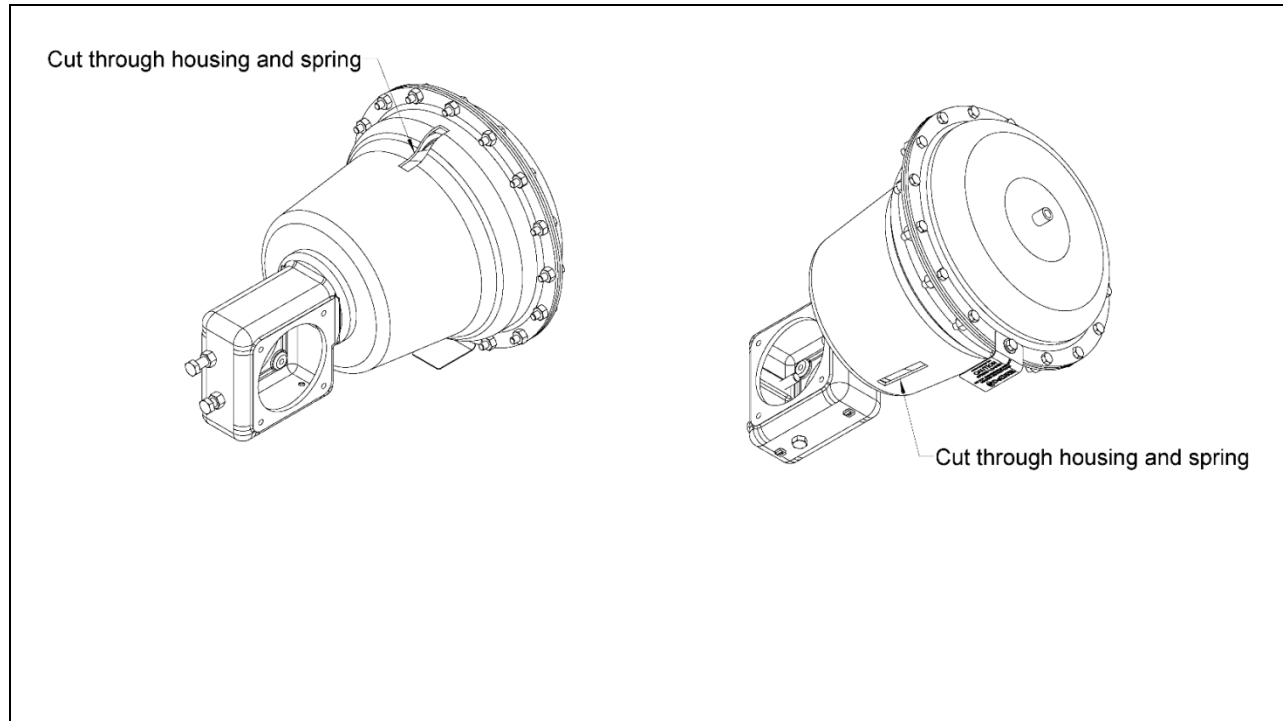

**Figure 4—Actuator Disposal**

DeZURIK  
**DR-85B Rotary Diaphragm Actuator**

---

## Troubleshooting

Condition	Possible Cause	Corrective Action
Actuator will not operate valve.	Rubber diaphragm is ruptured.	Replace diaphragm. See <i>Diaphragm Replacement</i> section.
	Lockable model is locked.	Place in unlocked condition. See <i>Lockable Model</i> section.
Actuator closes to wrong position.	Closed position stop is set incorrectly.	Adjust closed position stop. See <i>Open and Closed Position Stops</i> section.
Actuator opens to wrong position.	Open position stop is set incorrectly.	Adjust open position stop. See <i>Open and Closed Position Stops</i> section.
Actuator will not fully operate valve.	Actuator air pressure is low.	Increase air pressure. Do not exceed spring rating.
	Actuator is sized incorrectly.	Use spring with increased rating, or use larger actuator.
	Pipeline obstruction in valve is preventing closure.	Remove obstruction.
Spring operates valve in wrong direction.	Spring-to-close should be spring-to-open or vice versa.	Reverse the action. See <i>Reversing Actuator Action</i> section.

## Limited Warranty

DeZURIK, Inc. ("Seller") manufactured products, auxiliaries and parts for a period of twenty-four (24) months from date of shipment from Seller's factory, are warranted to the original purchaser only against defective workmanship and material, but only if properly stored, installed, operated, and serviced in accordance with Seller's recommendations and instructions.

For items proven to be defective within the warranty period, your exclusive remedy under this limited warranty is repair or replacement of the defective item, at Seller's option, FCA Incoterms 2020 Seller's facility with removal, transportation, and installation at your cost.

Products or parts manufactured by others but furnished by Seller are not covered by this limited warranty. Seller will provide repair or replacement for other's products or parts only to the extent provided in and honored by the original manufacturer's warranty to Seller, in each case subject to the limitations contained in the original manufacturer's warranty.

No claim for transportation, labor, or special or consequential damages or any other loss, cost or damage is being provided in this limited warranty. You shall be solely responsible for determining suitability for use and in no event shall Seller be liable in this respect.

This limited warranty does not warrant that any Seller product or part is resistant to corrosion, erosion, abrasion or other sources of failure, nor does Seller warrant a minimum length of service.

Your failure to give written notice to us of any alleged defect under this warranty within twenty (20) days of its discovery, or attempts by someone other than Seller or its authorized representatives to remedy the alleged defects therein, or failure to return product or parts for repair or replacement as herein provided, or failure to store, install, or operate said products and parts according to the recommendations and instructions furnished by Seller shall be a waiver by you of all rights under this limited warranty.

This limited warranty is voided by any misuse, modification, abuse or alteration of Seller's product, accident, fire, flood or other Act of God, or your failure to pay entire contract price when due.

The foregoing limited warranty shall be null and void if, after shipment from our factory, the item is modified in any way or a component of another manufacturer, such as but not limited to, an actuator is attached to the item by anyone other than a Seller factory authorized service personnel.

All orders accepted shall be deemed accepted subject to this limited warranty, which shall be exclusive of any other or previous Warranty, and this shall be the only effective guarantee or warranty binding on Seller, despite anything to the contrary contained in the purchase order or represented by any agent or employee of Seller in writing or otherwise, notwithstanding, including but not limited to implied warranties.

THE FOREGOING REPAIR AND REPLACEMENT LIMITED WARRANTY IS IN LIEU OF ALL OTHER WARRANTIES, OBLIGATIONS AND LIABILITIES, INCLUDING ALL WARRANTIES OF FITNESS FOR A PARTICULAR PURPOSE OR OF MERCHANTABILITY OR OTHERWISE, EXPRESSED OR IMPLIED IN FACT OR BY LAW, AND STATE SELLER'S ENTIRE AND EXCLUSIVE LIABILITY AND YOUR EXCLUSIVE REMEDY FOR ANY CLAIM IN CONNECTION WITH THE SALE AND FURNISHING OF SERVICES, GOODS OR PARTS, THEIR DESIGN, SUITABILITY FOR USE, INSTALLATION OR OPERATIONS.

## Disclaimer

Metric fasteners should not be used with ASME Class 150/300 bolt holes and flange bolt patterns. If you use metric fasteners with ASME Class 150/300 bolt holes and flange bolt patterns, it may lead to product failure, injury, and loss of life. DeZURIK Inc. disclaims all liability associated with the use of metric fasteners with ASME Class 150/300 bolt holes and flange patterns, including but not limited to personal injury, loss of life, loss of product, production time, equipment, property damage, lost profits, consequential damages of any kind and environment damage and/or cleanup. Use of metric fasteners with ASME Class 150/300 bolt holes and flange bolt patterns is a misuse that voids all warranties and contractual assurances. If you use metric fasteners with ASME Class 150/300 bolt holes and flange bolt patterns, you do so at your sole risk and any liability associated with such use shall not be the responsibility of DeZURIK, Inc. In addition to the foregoing, DeZURIK's Manufacturer's Conditions apply.

## Limitation of Liability

IN NO EVENT SHALL SELLER BE LIABLE FOR ANY DIRECT, INDIRECT, SPECIAL, PUNITIVE, OR CONSEQUENTIAL DAMAGES WHATSOEVER, AND SELLER'S LIABILITY, UNDER NO CIRCUMSTANCES, WILL EXCEED THE CONTRACT PRICE FOR THE GOODS AND/OR SERVICES FOR WHICH LIABILITY IS CLAIMED. ANY ACTION FOR BREACH OF CONTRACT BY YOU, OTHER THAN RIGHTS RESPECTING OUR LIMITED WARRANTY DESCRIBED ABOVE, MUST BE COMMENCED WITHIN 12 MONTHS AFTER THE DATE OF SALE.

## Sales and Service

For information about our worldwide locations, approvals, certifications and local representative:

Web site: [www.dezurik.com](http://www.dezurik.com) E-Mail: [info@dezurik.com](mailto:info@dezurik.com)



250 Riverside Ave. N., Sartell, MN 56377 • Phone: 320-259-2000 • Fax: 320-259-2227

*DeZURIK, Inc. reserves the right to incorporate our latest design and material changes without notice or obligation. Design features, materials of construction and dimensional data, as described in this manual, are provided for your information only and should not be relied upon unless confirmed in writing by DeZURIK, Inc. Certified drawings are available upon request.*