

APCO CSD-800 SLANTING DISC CHECK VALVES



Instruction D12012
July 2017

Instructions

These instructions are for use by personnel who are responsible for the installation, operation and maintenance of DeZURIK valves, actuators or accessories.

Safety Messages

All safety messages in the instructions are identified by a general warning sign and the signal word CAUTION, WARNING or DANGER. These messages indicate procedures to avoid injury or death.

Safety label(s) on the product indicate hazards that can cause injury or death. If a safety label becomes difficult to see or read, or if a label has been removed, please contact DeZURIK for replacement label(s).

⚠WARNING

Personnel involved in the installation or maintenance of valves should be constantly alert to potential emission of pipeline material and take appropriate safety precautions. Always wear suitable protection when dealing with hazardous pipeline materials. Handle valves which have been removed from service with suitable protection for any potential pipeline material in the valve.

Inspection

Your DeZURIK product has been packaged to provide protection during shipment; however, items can be damaged in transport. Carefully inspect the unit for damage upon arrival and file a claim with the carrier if damage is apparent.

Parts

Replaceable wear parts are listed on the assembly drawing. These parts can be stocked to minimize downtime. Order parts from your local DeZURIK sales representative or directly from DeZURIK. When ordering parts please provide the following information:

If the valve has a data plate: please include the 7-digit part number with either 4-digit revision number (example: 9999999R000) or 8-digit serial number (example: S1900001) whichever is applicable. The data plate will be attached to the valve assembly. Also, include the part name, the assembly drawing number, the balloon number and the quantity stated on the assembly drawing.

If there isn't any data plate visible on the valve: please include valve model number, part name, and item number from the assembly drawing. You may contact your local DeZURIK Representative to help you identify your valve.

DeZURIK Service

DeZURIK service personnel are available to maintain and repair all DeZURIK products. DeZURIK also offers customized training programs and consultation services. For more information, contact your local DeZURIK sales representative or visit our website at DeZURIK.com.

Table of Contents

Description - - - - -	4
Handling and Storage - - - - -	4
Installation - - - - -	4
Fusion/Powder Coated Valves - - - - -	5
Maintenance - - - - -	5
<i>CSD-800 Valves</i> - - - - -	5
<i>CSD-800-BMB Valves</i> - - - - -	5
<i>CSD-800-TMD Valves</i> - - - - -	5
<i>Valve Body Disassembly</i> - - - - -	6
<i>Valve Body Assembly</i> - - - - -	6
Operation - - - - -	8
<i>CSD-800-BMB Valves</i> - - - - -	8
<i>CSD-800-TMD Valves</i> - - - - -	9
<i>Start-up Procedure (CSD-800 Valves)</i> - - - - -	11
<i>Start-up Procedure (CSD-800-BMB Valves)</i> - - - - -	11
<i>Start-up Procedure (CSD-800-TMD Valves)</i> - - - - -	12
Adjustment of Flow Control Valve - - - - -	13
Operation of Internal Cushion - - - - -	14
Oil Filling Procedure - - - - -	14
<i>CSD-800-BMB Valves</i> - - - - -	14
<i>CSD-800-TMD Valves</i> - - - - -	15
Drawings - - - - -	16
Troubleshooting - - - - -	17

Description

A slanting disc check valve consists of a 2 piece valve body, a disc connected to a pivot pin, and a seat ring held between the 2 piece body. The disk swings away from the valve-seat to allow flow in the forward direction, and returns to valve-seat when upstream flow is stopped, to prevent backflow.

The CSD-800-BMB valve is equipped with a Bottom Mounted Buffer. The CSD-800-TMD valve is equipped with a Top Mounted Oil Dashpot.

Handling and Storage

Lifting the valve improperly may damage it. Do not fasten lifting devices to piping, attached components, the cylinder or through the seat opening in the body. Lift the valve with slings, chains or cables fastened around the valve body, or fastened to bolts or rods through bolt holes in the flanges.

If installation will be delayed, place valve indoors in secure, weather tight storage. If temporary outside storage is unavoidable, make sure a vermin proof rain cover (water shedding tarp, etc.) is secured around/over the valve to keep off rain and mud. Skid and set the assembly on a flat, solid, and well drained surface for protection from ground moisture, runoff and pooled rain water.

Installation

- The APCO CSD-800 Slanting Disc Check Valve may be installed in a horizontal position. Contact DeZurik if installed in vertical position with the flow upward. The embossed flow arrow on the valve body should be pointing in the direction of flow. In all cases however, with the CSD-800-BMB, the tanks (27) and (32) must always be in the upright position with piping from the dashpot cylinder (39) entering at the bottom of the tanks (see Figure 1.) With the CSD-800-TMD, the tanks (73) and (74) also must always be in an upright position (see Figure 2.) Unless otherwise specified, the valves are shipped for horizontal installation.
- Before installation, remove foreign material such as weld spatter, oil, grease, and dirt from the pipeline.
- Prepare pipe ends and install valves in accordance with the pipe manufacture's instructions for the joint used.



CAUTION!

Do not deflect the pipe-valve joint. Minimize bending stresses in the valve end connection with pipe loading.

If excessive seat leakage occurs during start-up, recheck the installation and eliminate any distortion to the valve body.

- Ensure the valve and pipeline flanges are concentric to ensure proper flange sealing and seat leakage control.
- Tighten the flange bolts or studs in a crisscross pattern and minimum of four stages.

Fusion/Powder Coated Valves

**CAUTION!**

Valves with fusion/powder coated exterior paint require flat washers to be installed under the flange nuts when installing the valve to the pipeline flange to prevent the paint from cracking or chipping.

Maintenance

CSD-800 Valves

The APCO Slanting Disc Check Valve requires very little regular maintenance except for periodic (approximately 6 months) greasing of pivot pins, and occasional observation of the disc position indicator to ensure that the valve disc is opening.

The Pivot Pins (13) on each side of the valve should be lubricated at least once a year with white water proof, FDA approved Lubriplate grease. The amount of grease to be injected depends on the size of the valve. Two strokes of a hand grease gun is needed for sizes up to 24", and 3 strokes for sizes 30" and larger.

The Check Valve is fitted with 2 covered accessory openings, one in each body half. These covers may be removed to observe inside the valve to determine whether any leakage or blockage is occurring.

CSD-800-BMB Valves

The CSD-800-BMB Slanting Disc Check Valve is shipped from the factory fully lubricated and oil tanks filled with hydraulic oil to their proper levels ready for installation. It requires a very minimal amount of preventive maintenance.

Special care should be taken to the exposed area of the Buffer Rod when painting the valve. It should be fully masked to prevent even a small amount of paint from getting on the Buffer Rod which could damage the cylinder rod seal and cause the cylinder to leak.

CSD-800-TMD Valves

Through the course of operation the upper half of dashpot piping must be checked for the loss of pressure. It is normal for the system to indicate an increased pressure when the valve opens due to the transfer of oil from the cylinder to the hydro-pneumatic tank, which further compresses the pressurized air in the tank. If system is losing pressure, check for oil leaks along the dashpot piping or on the hydro-pneumatic tank air valve and follow "Oil Filling Procedure".

APCO CSD-800 Slanting Disc Check Valves

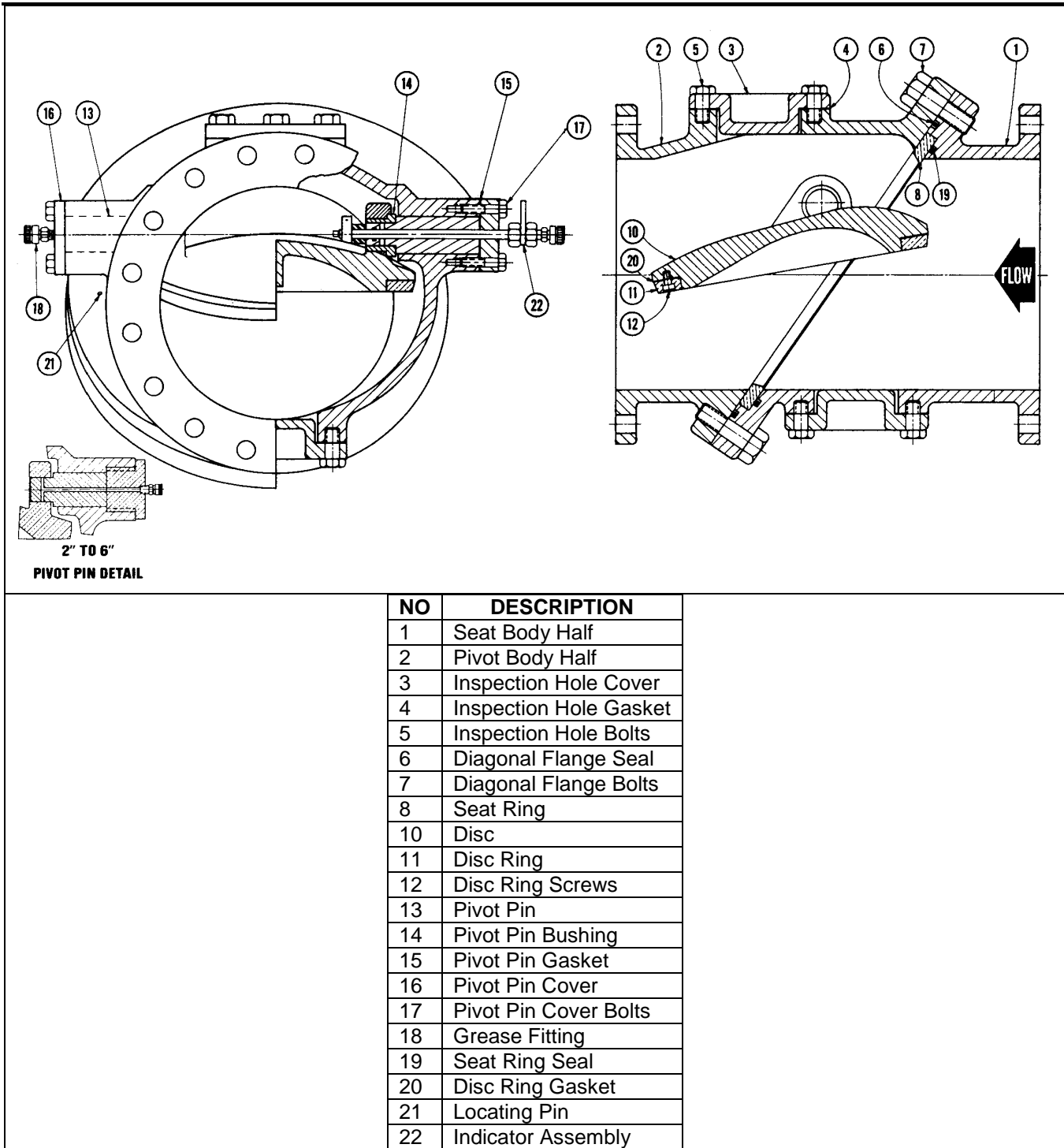

Figure 6: CSD-800 Slanting Disc Check Valve

APCO CSD-800 Slanting Disc Check Valves**Maintenance** *(Continued)***Valve Body Disassembly**

See Figure 6 for part identification.

**WARNING!**

These valves may open or close without warning due to flow changes from pumps starting and stopping. Servicing these valves while the pipeline is under pressure can cause personal injury or equipment damage.

Workers must be cautious when working around these valves.

Relieve pipeline pressure and lockout the pumps before servicing the valve.

1. Relieve pipeline pressure and lockout the pumps before servicing the valve.
2. Either remove the valve completely from the pipeline to separate the two diagonal flanges or leave the inlet half (1) bolted in place.
3. Lay valve on the floor with the pivot body half (2) on top.
4. Drive out the two locating pins (21) and remove diagonal flange bolts (7).
5. Remove pivot pin cover screws (17), pivot pin covers (16), pivot pin cover gaskets (15) and pivot pins (13) from pivot body half (2).
6. Lift off pivot body half (2), and then the disc (10).
7. Inspect all wear parts and seating surfaces and replace if necessary.

Valve Body Assembly

See Figure 6 for part identification.

1. If seat ring (8) is damaged, remove seat ring from seat body half (1). If seat ring seal (19) is damaged, remove old seat ring seal and place new seat ring seal and new seat ring in seat body half.
2. If diagonal flange seal (6) is damaged, remove old seal from seat body half (1) and place a new diagonal flange seal in seat body half.
3. If disc ring (11) is damaged, remove disc ring screws (12) and disc ring from disc (10).
4. If disc ring gasket (20) is damaged, remove old gasket from disc (10), place a new disc ring gasket in disc and attach new disc ring (11) with disc ring screws (12) to disc.
5. If pivot pin bushings (14) are damaged, remove old bushings and place new bushings in disc (10).
6. Place disc (10) into pivot body half (2) and inset pivot pins (13) into pivot body half.
7. If pivot pin cover gaskets (15) are damaged, place new gaskets on into pivot body half (2) and attach pivot pin covers (16) with pivot pin cover screws (17) to pivot body half.
8. Place pivot body half (2) assembly on seat body half (1) , line up locating pin holes and insert pins (21) into seat body half (1) and pivot body half (2).

Maintenance *(Continued)*

9. Screw diagonal flange bolts (7) in place but do not tighten.
10. Manually open and close disc (10) to check for binding and proper seating.
11. Tighten all diagonal flange bolts (7).
12. Place valve back in pipeline.

Operation

The valve as shipped from the factory may require minor adjustment, but is ready for operation. The main body is 2 pieces to allow a greatly enlarged flow area through the disc and seat section. The disc pivots off center with approximately 30% of the disc area above the pivot point to offer resistance against the 70% disc area below the pivot point.

The shut off seating angle is 55°. The disc swings open through this 55° seat angle, traveling a short distance, stopping at 15° off the horizontal.

CSD-800-BMB Valves

See Figure 1 for part identification.

Bottom Mounted Buffers are used when a free open and partial control of the disc during the closing cycle is required. This unique arrangement allows the valve disc to close freely for the major portion of its travel from full open to close. During the closing cycle, the disc comes in contact with the Buffer Rod (33) which controls the speed of closing over the last 10% of the disc travel. This type of control provides for adjustment to suit the best performance for the installation.

The oil operated Buffer Cylinder (39) incorporates the use of a two tank system of air over oil hydraulics to operate the Buffer. The use of oil as the controlling media in this hydraulic system creates a separate closed system which prevents contamination of the pipeline media.

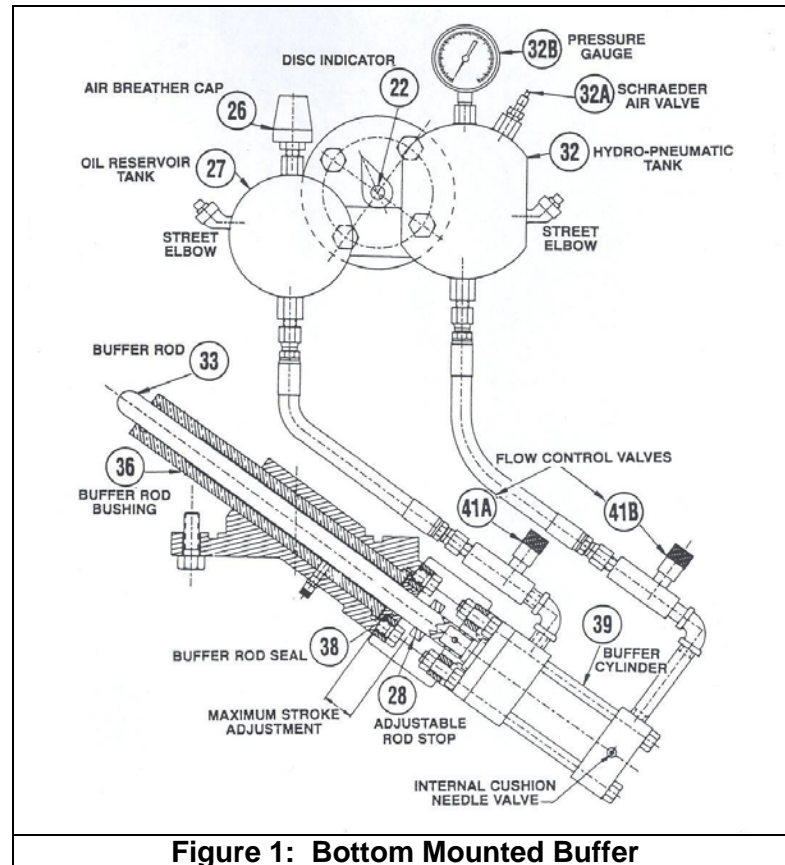
APCO CSD-800 Slanting Disc Check Valves**Operation (Continued)****Figure 1: Bottom Mounted Buffer****CSD-800-TMD Valves**

See Figure 2 for part identification.

Top Mounted Oil Dashpots are used when full control of Disc (10) movement, during either the opening or closing cycle, is required. This type of control provides for adjustment to suit the best performance for the installation.

Under no circumstance is the valve to be used as a pump control valve. Conditions of operation or adjustment other than contained herein must be discussed with the factory.

The Top mounted Oil Dashpot offers single-stage control in the opening cycle and two-stage control in the closing cycle. The primary control of the closing cycle and full control of opening cycle are the Flow Control Valves (64). The primary control of the closing cycle handles the first stage of the disc movement. The secondary control is located in the head of the cylinder itself, which is the cushion adjustment and provides additional control over the last stage of disc closing movement. See "Operation of Internal Cushion".

The oil operated Dashpot Cylinder (59) incorporates the use of a two-tank system of air over oil hydraulics to operate the dashpot. The use of oil as the controlling media in this hydraulic system creates a separate closed system which prevents contamination of the pipeline media.

Operation (Continued)

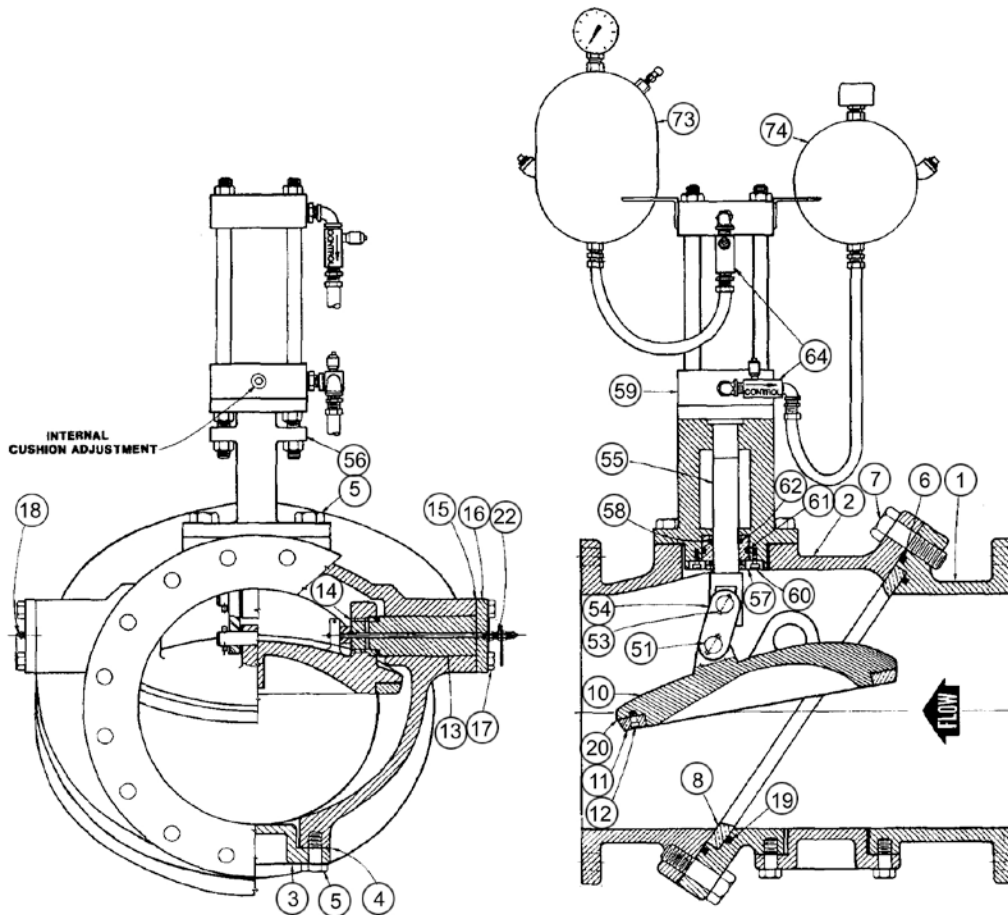

NO	DESCRIPTION	NO	DESCRIPTION
1	Seat Body Half	19	Seat Ring Seal
2	Pivot body Half	20	Disc Ring Gasket
3	Inspection Hole Cover	22	Indicator Assembly
4	Inspection Hole Gasket	51	Linkage Pin
5	Inspection Hole Bolt	53	Linkage Tension Pin
6	Diagonal Flange Seal	54	Pivot Linkage
7	Diagonal Flange Bolt	55	Connecting Rod
8	Seat Ring	56	Dashpot Spacer
10	Disc	57	Bushing Retaining Ring
11	Disc Ring	58	Connecting Rod Bushing
12	Disc Ring Retaining Screws	59	Dashpot Cylinder
13	Pivot Pin	60	Bushing Retaining Screw
14	Pivot Pin Bushing	61	Bushing Seal
15	Pivot Pin Gasket	62	Connecting Rod Seal
16	Pivot Pin Cover	64	Flow Control Valve
17	Pivot Pin Cover Bolt	73	Hydro-pneumatic Tank
18	Grease Fitting	74	Oil Reservoir

Figure 2: CSD-800-TMD Slanting Disc Check Valve with Top Mounted Oil Dashpot

Start-up Procedure (CSD-800 Valves)

**CAUTION!**

Do not start up the Check Valve with the downstream Gate Valve or Butterfly Valve fully open.

1. Observe the Disc Position Indicator to be sure the Disc is in the closed position.
2. With the Check Valve Disc completely closed, partly close the Gate or Butterfly valve downstream of the Check Valve approximately 50% to minimize the amount of water column reversal against the disc during the initial testing with the pump starts and stops.
3. Start pump and observe Disc Position Indicator to be sure the Disc is opening. The Disc should open smoothly.
4. Shut down pump and observe the Disc closing. The disc should close smoothly with a slight thud to indicate its shutoff.
5. Using the above trial run procedure, make several pump starts and stops while increasing the opening of the downstream Gate or Butterfly Valve to its fully open position.

Start-up Procedure (CSD-800-BMB Valves)

See Figure 1 for part identification.

1. Check for proper oil levels. Make sure both oil tanks are in vertical position.
 - a. **Hydro-pneumatic Tank (32):** Release air pressure and remove pipe plug on the side of the tank. Oil should be visible in the elbow, which is the oil fill level. Add if necessary. See "Oil Filling Procedure".
 - b. **Oil Reservoir (27):** The oil level should be checked when the valve is open. Oil should be visible in the elbow, which is the oil fill level. Add if necessary. See "Oil Filling Procedure".
2. Make initial adjustments to the following speed controls:
 - a. Flow Control Valve (41B) = 3 turns open. See "Adjustment of Flow Control Valve".
 - b. Flow Control Valve (41A) = Full open.
 - c. Internal Cushion Needle Valve = 1-1/2 turns open. See "Operation of Internal Cushion".
3. Pressurize Hydro-pneumatic tank to a pressure according to the formula:

$$\text{Tank pressure} = \frac{\text{Line pressure}}{4} + 5 \text{ psi}$$
4. Start pump. While valve is opening, visually ascertain that Buffer Rod (33) fully extends into the valve body. If not, pressurize Hydro-pneumatic tank until it does. Table A shows the maximum stroke adjustment of the Buffer Rod for CSD-800-BMB Slanting Disc Check Valves.

Operation *(Continued)*

Table A: Maximum Stroke Adjustment of the Buffer Rod

Valve Size	6	8	10	12	14	16	18	20
Buffer Rod Stroke (in)	1/2	5/8	3/4	3/4	3/4	3/4	7/8	1
Valve Size	24	30	36	42	48	54	60	
Buffer Rod Stroke (in)	1-1/4	1-1/4	1-1/2	1-7/8	2-1/4	2-3/8	2-5/8	

5. Shut-off pump and observe rate of closing. Based on this initial run make necessary adjustments to the Flow Control Valve (41B) and/or the Internal Cushion Needle Valve until satisfactory closing is achieved.

An Adjustable Rod Stop (28) is mounted on the Buffer Rod to lock it in place when it is necessary to disconnect the hydraulic cylinder for repairs while pump is running. In very rare cases however, it can be used to shorten the Buffer Rod stroke when the system demands a higher percentage of free fall closing of the Disc.

The Slanting Disc Check Valve with Bottom Mounted Buffer has two controlling stages in the closing cycle. The Flow Control Valve (41B) controls the first stage of Disc closure and the secondary control is the Internal Cushion Needle Valve which controls the remaining 20% of the Buffer stroke.

Start-up Procedure (CSD-800-TMD Valves)

See Figure 2 for part identification.

1. With the valve disc completely closed and both the hydro-pneumatic tank and oil reservoir in a vertical position, check oil levels. Fill both tanks to the “street elbow” located on side with oil as specified in “Oil Filling Procedure”. The Oil Reservoir (74) is provided with a breather cap, so that at all times it remains at atmospheric pressure.
2. Using tire pump, pressurize the hydro-pneumatic tank (73) to a pressure as determined by the formula below. This is the pressure at which the first pump start & stop tests will be made through step 6, after which the pressure can be increased in increments of 2 psi, if the line conditions require a faster response of closing of the disc on pump shutdown.

Tank pressure = $K \times P$ WHERE: P = Line pressure, PSI K= Valve Constant (See Table below)

Valve size	K	Valve size	K
6"	0.19	20"	0.21
8"	0.21	24"	0.21
10"	0.21	30"	0.30
12"	0.23	36"	0.30
14"	0.23	42"	0.24
16"	0.19	48"	0.30
18"	0.19	54" *	

*54" and larger Contact Factory.

Operation *(Continued)*

3. Open the two Flow control Valves (64) connected to the dashpot piping adjacent to the cylinder in the following manner:
 - a. Fully open Flow Control Valve located at the top of the dashpot piping which controls the rate of opening.
 - b. Open the Flow Control Valve located at the bottom of dashpot piping, which controls the rate of closing, three complete turns counterclockwise from fully closed position. See "Adjustment of Flow Control Valve".
4. Turn cushion adjustment screw on the dashpot cylinder (59) one complete turn counterclockwise from fully closed position. See "Operation of Internal Cushion".
5. Start pump and observe rate of opening.
6. Shut down pump and observe rate of closing.
7. Using the above trial run as a basis, make necessary adjustments on the Flow Control Valves to suit the installation. Over control of the opening cycle of the Slanting Disc Check Valve can damage the connecting rod (55). Therefore, the Flow Control Valve (64) (step 3a) controlling the opening cycle must never be closed less than two full turns open.
8. Tighten set screw or lock nut under both Flow Control Valve knobs when final setting is made to prevent tampering of settings.

**CAUTION!**

UNDER NO CIRCUMSTANCES SHOULD EITHER OF THE FLOW CONTROL VALVES BE FULLY CLOSED WHEN THE PUMP IS BEING STARTED

Adjustment of Flow Control Valve

The Flow Control Valve, Figure 3, has a micrometer type adjustment which incorporates a color coded reference scale to simplify setting, resetting and adjusting.

A set screw on the knob (see Figure 3) is provided for locking the valve setting. Turning the knob clockwise closes the valve and turning counterclockwise opens the valve and increases rate of closure of the Check Valve.

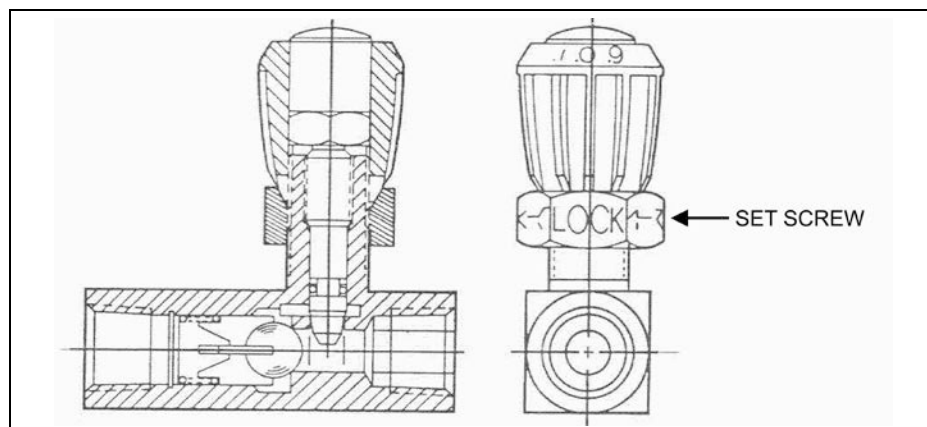

Figure 3: Flow Control Valve

Operation of Internal Cushion

The cushioning of a hydraulic cylinder stroke is obtained by trapping the exhaust oil as the piston assembly nears the end of its stroke. In Figure 4, as the Cushion Plunger (1) enters Cushion Cavity (2), the exhaust oil is almost completely trapped by the Ball Check (3) and the Adjusting Screw (4) creating a back pressure against Piston Assembly. The back pressure cushions and slows the final part of the Piston stroke, thus reducing the high impact hammering of the Piston Assembly against the Cylinder Cap.

Turning the Adjusting Screw to allow more or less oil to escape regulates the degree of cushioning as desired.

In Figure 5, when oil enters the Cylinder Cap End to stroke the Piston Assembly in the opposite direction, the oil moves the Ball Check (3) off its seat, opening the passage for more oil to act against the Piston, thus speeding its start-up movement as the Cushion Plunger (1) is immediately forced out of its cavity (2).

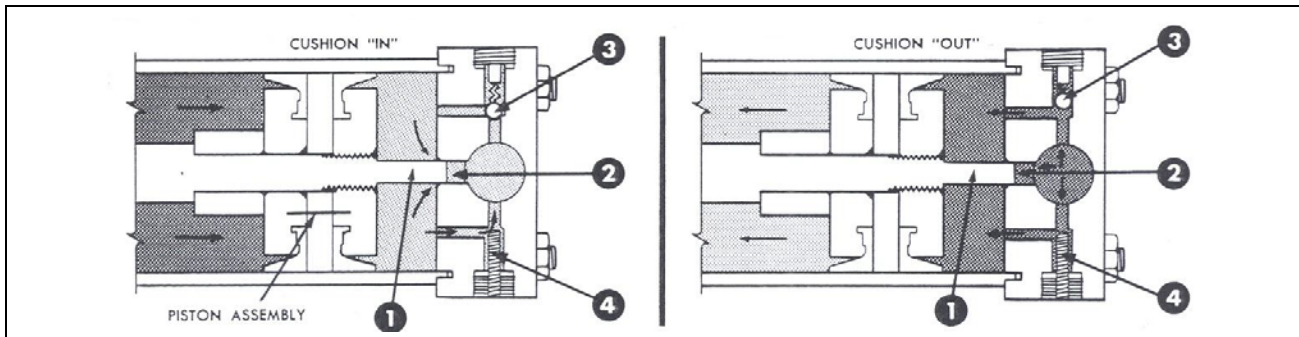

Figure 4: Cushion "IN" Stroke

Figure 5: Cushion "OUT" Stroke

Oil Filling Procedure

CSD-800-BMB Valves

-See Figure 1

1. Hydro-pneumatic tank (32)

- a. Shut down pump.
- b. Release air pressure of hydro-pneumatic tank and remove pipe plug located on the side of the tank and also either the Pressure Gauge (32B) or Air Valve (32A).
- c. Fully open Flow Control Valve (41B) and slowly fill cylinder with SAE 20 oil or equivalent until it spills out of the side port. This is the oil fill level.
- d. Replace both fittings and pressurize tank according to the formula;

$$\text{Tank pressure} = \frac{\text{Line pressure}}{4} + 5 \text{ psi}$$

- e. Set flow control valve three turns counterclockwise from fully closed position.
- f. Start pump and observe if buffer rod (33) extends. If not, while valve is still open add more pressure in increments of 5 PSI until rod fully extends.

Oil Filling Procedure *(Continued)***2. Oil Reservoir (27)**

- a. Start pump.
- b. Fully open Flow Control Valve (41A).
- c. Remove side pipe plug and Breather Cap (26) and slowly fill with oil until it spills out of the side port.
- d. Replace both fittings.
- e. Shut down pump.

NOTE: The Oil Reservoir should always be under atmospheric condition at all times.

CSD-800-TMD Valves**1. Hydro-pneumatic tank (73)**

- a. Shut down pump.
- b. Release air pressure of Hydro-pneumatic tank and remove pipe plug located on the side of the tank and also either the Pressure Gauge or Air Valve.
- c. Fully open Flow Control Valve and slowly fill cylinder with SAE 20 oil or equivalent until it spills out of the side port. This is the oil fill level.
- d. Replace both fittings and pressurize tank as shown in "Start-up Procedure"
- e. Set flow control valve three turns counterclockwise from fully closed position.

2. Oil Reservoir (74)

- a. Shut down pump.
- b. Fully open Flow Control Valve.
- c. Remove side plug and Breather Cap and slowly fill with oil until it almost spills out of the side port. This is the oil fill level.
- d. Replace both fittings.
- e. Start pump.

NOTE: There is no need to purge any entrapped air because this connection is under atmospheric condition at all times.

Drawings

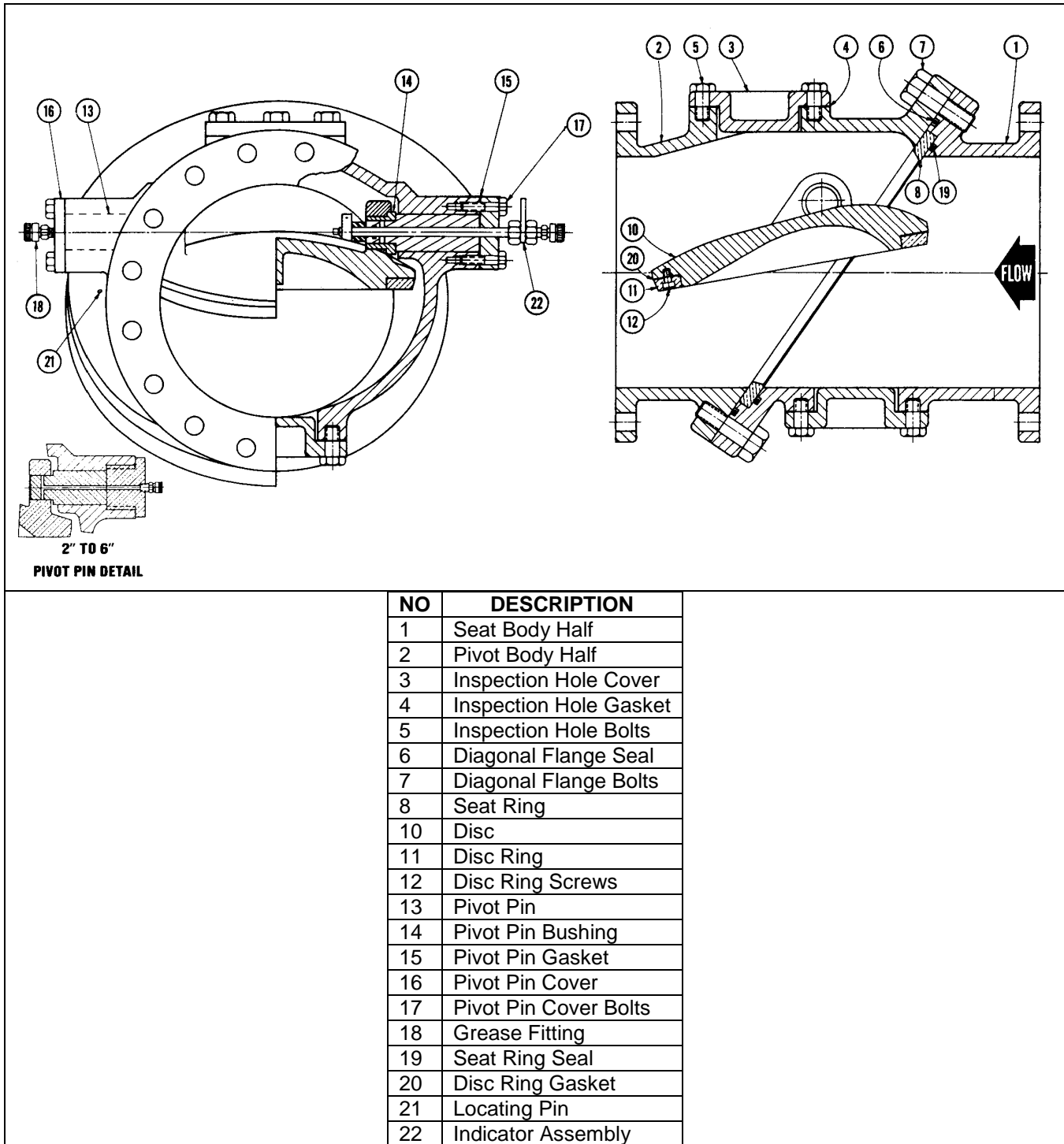

Figure 6: CSD-800 Slanting Disc Check Valve

APCO CSD-800 Slanting Disc Check Valves

Troubleshooting

Condition	Possible Cause	Corrective Action
Valve leaks excessively from one side of the disc to the other.	Foreign matter caught between disc and seat.	Fully open valve to remove object.
	Seat ring and/or disc ring are worn or damaged.	Replace seat ring and/or disc ring.
Valve leaks at flange joint.	Loose flange bolting.	Tighten flange bolting.
	Blown flange gasket.	Replace flange gasket.
	Misalignment or damage to field piping and supports.	Adjust misalignment or repair piping or supports.
	Damaged flange face/s or improper flange connections.	Repair flange, replace valve body or adjust flange connections.

Limited Warranty

DeZURIK, Inc. ("Seller") manufactured products, auxiliaries and parts for a period of twenty-four (24) months from date of shipment from Seller's factory, are warranted to the original purchaser only against defective workmanship and material, but only if properly stored, installed, operated, and serviced in accordance with Seller's recommendations and instructions.

For items proven to be defective within the warranty period, your exclusive remedy under this limited warranty is repair or replacement of the defective item, at Seller's option, FCA Incoterms 2020 Seller's facility with removal, transportation, and installation at your cost.

Products or parts manufactured by others but furnished by Seller are not covered by this limited warranty. Seller will provide repair or replacement for other's products or parts only to the extent provided in and honored by the original manufacturer's warranty to Seller, in each case subject to the limitations contained in the original manufacturer's warranty.

No claim for transportation, labor, or special or consequential damages or any other loss, cost or damage is being provided in this limited warranty. You shall be solely responsible for determining suitability for use and in no event shall Seller be liable in this respect.

This limited warranty does not warrant that any Seller product or part is resistant to corrosion, erosion, abrasion or other sources of failure, nor does Seller warrant a minimum length of service.

Your failure to give written notice to us of any alleged defect under this warranty within twenty (20) days of its discovery, or attempts by someone other than Seller or its authorized representatives to remedy the alleged defects therein, or failure to return product or parts for repair or replacement as herein provided, or failure to store, install, or operate said products and parts according to the recommendations and instructions furnished by Seller shall be a waiver by you of all rights under this limited warranty.

This limited warranty is voided by any misuse, modification, abuse or alteration of Seller's product, accident, fire, flood or other Act of God, or your failure to pay entire contract price when due.

The foregoing limited warranty shall be null and void if, after shipment from our factory, the item is modified in any way or a component of another manufacturer, such as but not limited to, an actuator is attached to the item by anyone other than a Seller factory authorized service personnel.

All orders accepted shall be deemed accepted subject to this limited warranty, which shall be exclusive of any other or previous Warranty, and this shall be the only effective guarantee or warranty binding on Seller, despite anything to the contrary contained in the purchase order or represented by any agent or employee of Seller in writing or otherwise, notwithstanding, including but not limited to implied warranties.

THE FOREGOING REPAIR AND REPLACEMENT LIMITED WARRANTY IS IN LIEU OF ALL OTHER WARRANTIES, OBLIGATIONS AND LIABILITIES, INCLUDING ALL WARRANTIES OF FITNESS FOR A PARTICULAR PURPOSE OR OF MERCHANTABILITY OR OTHERWISE, EXPRESSED OR IMPLIED IN FACT OR BY LAW, AND STATE SELLER'S ENTIRE AND EXCLUSIVE LIABILITY AND YOUR EXCLUSIVE REMEDY FOR ANY CLAIM IN CONNECTION WITH THE SALE AND FURNISHING OF SERVICES, GOODS OR PARTS, THEIR DESIGN, SUITABILITY FOR USE, INSTALLATION OR OPERATIONS.

Disclaimer

Metric fasteners should not be used with ASME Class 150/300 bolt holes and flange bolt patterns. If you use metric fasteners with ASME Class 150/300 bolt holes and flange bolt patterns, it may lead to product failure, injury, and loss of life. DeZURIK Inc. disclaims all liability associated with the use of metric fasteners with ASME Class 150/300 bolt holes and flange patterns, including but not limited to personal injury, loss of life, loss of product, production time, equipment, property damage, lost profits, consequential damages of any kind and environment damage and/or cleanup. Use of metric fasteners with ASME Class 150/300 bolt holes and flange bolt patterns is a misuse that voids all warranties and contractual assurances. If you use metric fasteners with ASME Class 150/300 bolt holes and flange bolt patterns, you do so at your sole risk and any liability associated with such use shall not be the responsibility of DeZURIK, Inc. In addition to the foregoing, DeZURIK's Manufacturer's Conditions apply.

Limitation of Liability

IN NO EVENT SHALL SELLER BE LIABLE FOR ANY DIRECT, INDIRECT, SPECIAL, PUNITIVE, OR CONSEQUENTIAL DAMAGES WHATSOEVER, AND SELLER'S LIABILITY, UNDER NO CIRCUMSTANCES, WILL EXCEED THE CONTRACT PRICE FOR THE GOODS AND/OR SERVICES FOR WHICH LIABILITY IS CLAIMED. ANY ACTION FOR BREACH OF CONTRACT BY YOU, OTHER THAN RIGHTS RESPECTING OUR LIMITED WARRANTY DESCRIBED ABOVE, MUST BE COMMENCED WITHIN 12 MONTHS AFTER THE DATE OF SALE.

Sales and Service

For information about our worldwide locations, approvals, certifications and local representative:

Web site: www.dezurik.com E-Mail: info@dezurik.com



250 Riverside Ave. N., Sartell, MN 56377 • Phone: 320-259-2000 • Fax: 320-259-2227

DeZURIK, Inc. reserves the right to incorporate our latest design and material changes without notice or obligation. Design features, materials of construction and dimensional data, as described in this manual, are provided for your information only and should not be relied upon unless confirmed in writing by DeZURIK, Inc. Certified drawings are available upon request.