

DEZURIK RCV ROTARY CONTROL VALVES

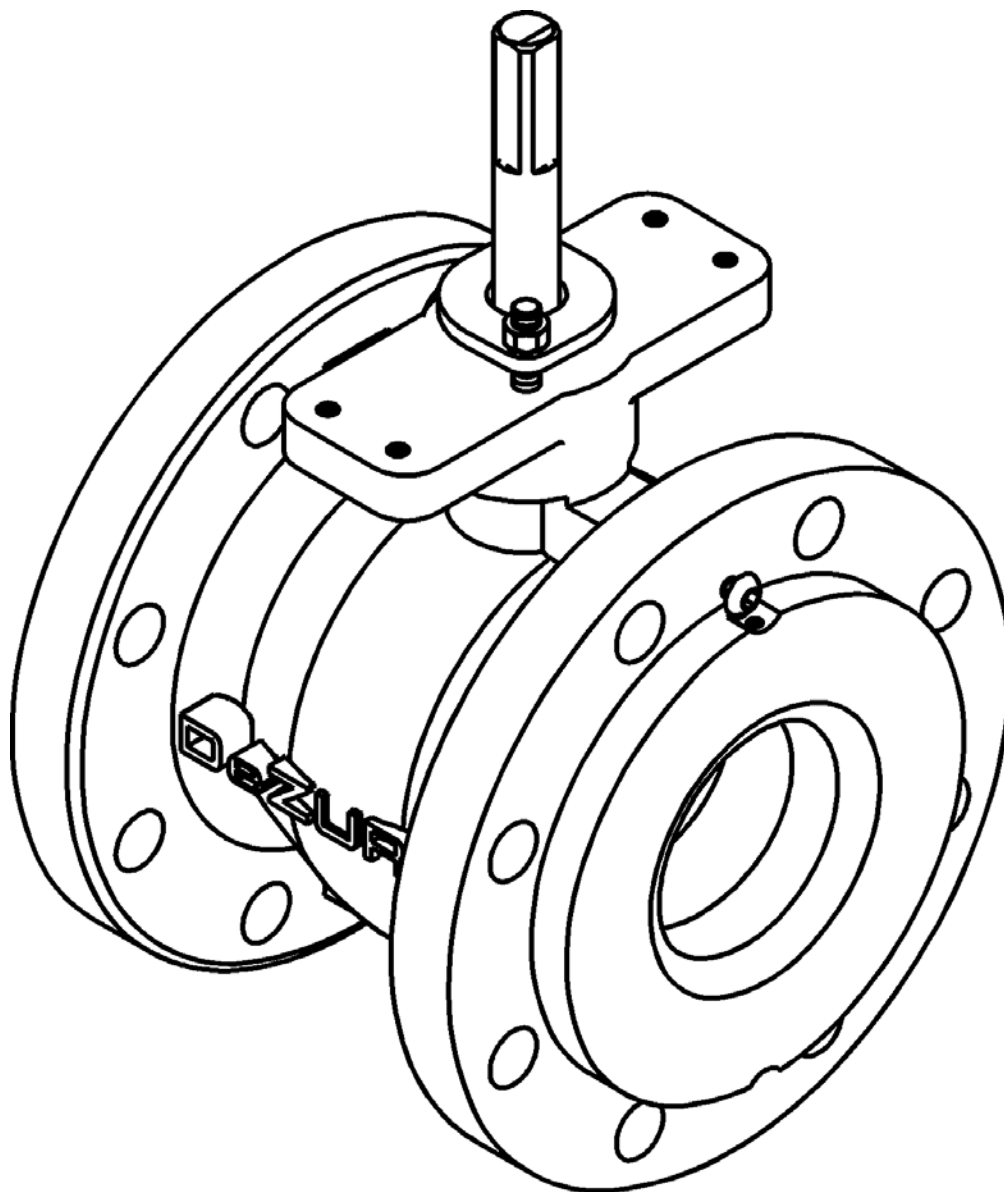

Instruction **D10361**
August 2018

DeZURIK

RCV Rotary Control Valves

Instructions

These instructions provide information about RCV Rotary Control Valves. They are for use by personnel who are responsible for installation, operation and maintenance of RCV Rotary Control Valves.

Safety Messages

All safety messages in the instructions are flagged with an exclamation symbol and the word Caution, Warning or Danger. These messages indicate procedures that must be followed exactly to avoid equipment damage, personal injury or death.

Safety label(s) on the product indicate hazards that can cause equipment damage, personal injury or death. If a safety label becomes difficult to see or read, or if a label has been removed, please contact DeZURIK for replacement label(s).



WARNING!

Personnel involved in the installation or maintenance of valves should be constantly alert to potential emission of pipeline material and take appropriate safety precautions. Always wear suitable protection when dealing with hazardous pipeline materials. Handle valves, which have been removed from service with suitable protection for any potential pipeline material in the valve.

Inspection

Your RCV Rotary Control Valve has been packaged to provide protection during shipment; however, it can be damaged in transport. Carefully inspect the unit for damage upon arrival and file a claim with the carrier if damage is apparent.

Parts

Recommended spare parts are listed on the assembly drawing. These parts should be stocked to minimize downtime.

Order parts from your DeZURIK sales representative, or directly from DeZURIK. When ordering parts, please include the 7-digit part number and 4-digit revision number (example: **9999999R000**) located on the data plate attached to the valve assembly. Also include the part name, the assembly drawing number, the balloon number and the quantity stated on the assembly drawing.

DeZURIK Service

DeZURIK service personnel are available to install, maintain and repair all DeZURIK products. DeZURIK also offers customized training programs and consultation services.

For more information, contact your local DeZURIK sales representative or visit our website at www.dezurik.com.

Table of Contents

Description - - - - -	4
Handling - - - - -	4
Installing Valve - - - - -	4
Operation - - - - -	5
Required Tools - - - - -	5
Lubrication - - - - -	5
Adjusting Packing - - - - -	5
Drawings - - - - -	6
Replacing Packing - - - - -	8
Seat Replacement - - - - -	9
Valve Disassembly - - - - -	12
Valve Reassembly - - - - -	13
Actuator Closed Position Stop Adjustment - - - - -	16
Troubleshooting - - - - -	16

DeZURIK

RCV Rotary Control Valves

Description

The RCV Rotary Control Valve is a quarter-turn control valve for corrosive and abrasive liquids, gases and slurries. A choice of materials, actuators, and accessories is available.

Handling

Lifting the valve improperly may damage it. Do not fasten lifting devices to the actuator, plug or through the seat opening in the body. Lift the valve with slings, chains or cables fastened around the valve body, or fastened to bolts or rods through bolt holes in the flanges.

Installing Valve



WARNING!

Metric fasteners should not be used with ASME Class 150/300 bolt holes and flange bolt patterns. If you use metric fasteners with ASME Class 150/300 bolt holes and flange bolt patterns, it may lead to product failure, injury, and loss of life. DeZURIK Inc. disclaims all liability associated with the use of metric fasteners with ASME Class 150/300 bolt holes and flange patterns, including but not limited to personal injury, loss of life, loss of product, production time, equipment, property damage, lost profits, consequential damages of any kind and environment damage and/or cleanup. Use of metric fasteners with ASME Class 150/300 bolt holes and flange bolt patterns is a misuse that voids all warranties and contractual assurances. If you use metric fasteners with ASME Class 150/300 bolt holes and flange bolt patterns, you do so at your sole risk and any liability associated with such use shall not be the responsibility of DeZURIK, Inc. In addition to the foregoing, DeZURIK's Manufacturer's Conditions apply.

Install the valve with self-centering flat ring gaskets and ANSI flanges. Use either Class 150 or Class 300 flanges, as designated above "CWP" on the valve data plate. Before installation, remove foreign material such as weld spatter, oil, grease, and dirt from the valve, flanges, and pipeline.

Refer to the Installation Tag attached to the valve for correct installation of valve in pipeline.

Close the valve, align the pipeline on both sides of the valve, and ensure that the flanges, gaskets and valve are centered before tightening the flange bolts or studs. Tighten the bolts or studs evenly, in a crisscross pattern.

Operation

Clockwise rotation of the valve shaft closes the plug in the valve. The plug is the closure member of the valve. As the plug rotates, a variable orifice is formed with the circular seat in the body. The valve actuator is connected to the valve shaft, and positions the plug at the open, closed, and intermediate positions.

The valve is fully closed when the plug touches the seat, and the valve is fully open when the plug is 90 degrees counterclockwise from the closed position. The open and closed positions are determined by the actuator. Refer to the Actuator Instructions for adjusting the open position stop. A line is stamped on the top of the valve stem to indicate the angular position of the plug when the plug is not visible. Refer to the top view of the shaft shown in Figure 2.

Required Tools

This valve is assembled using only SAE fasteners. To service this unit, you should have a full set of combination wrenches, Allen wrenches, a flat tipped screwdriver, a punch and a dead blow hammer.

Lubrication

The valve does not require lubrication except when it is being assembled. Refer to the actuator instructions for actuator lubrication requirements.

Adjusting Packing

The shaft seal consists of packing in the packing chamber of the body. The packing is contained and compressed by the packing gland. If the packing leaks, tighten the adjustment nuts (A8) on top of the packing gland (A9), shown in Figure 2. Tighten the nuts evenly and gently, just enough to stop the leakage. Over-tightening will cause excessive operating forces, and will decrease the life of the packing.

Drawings

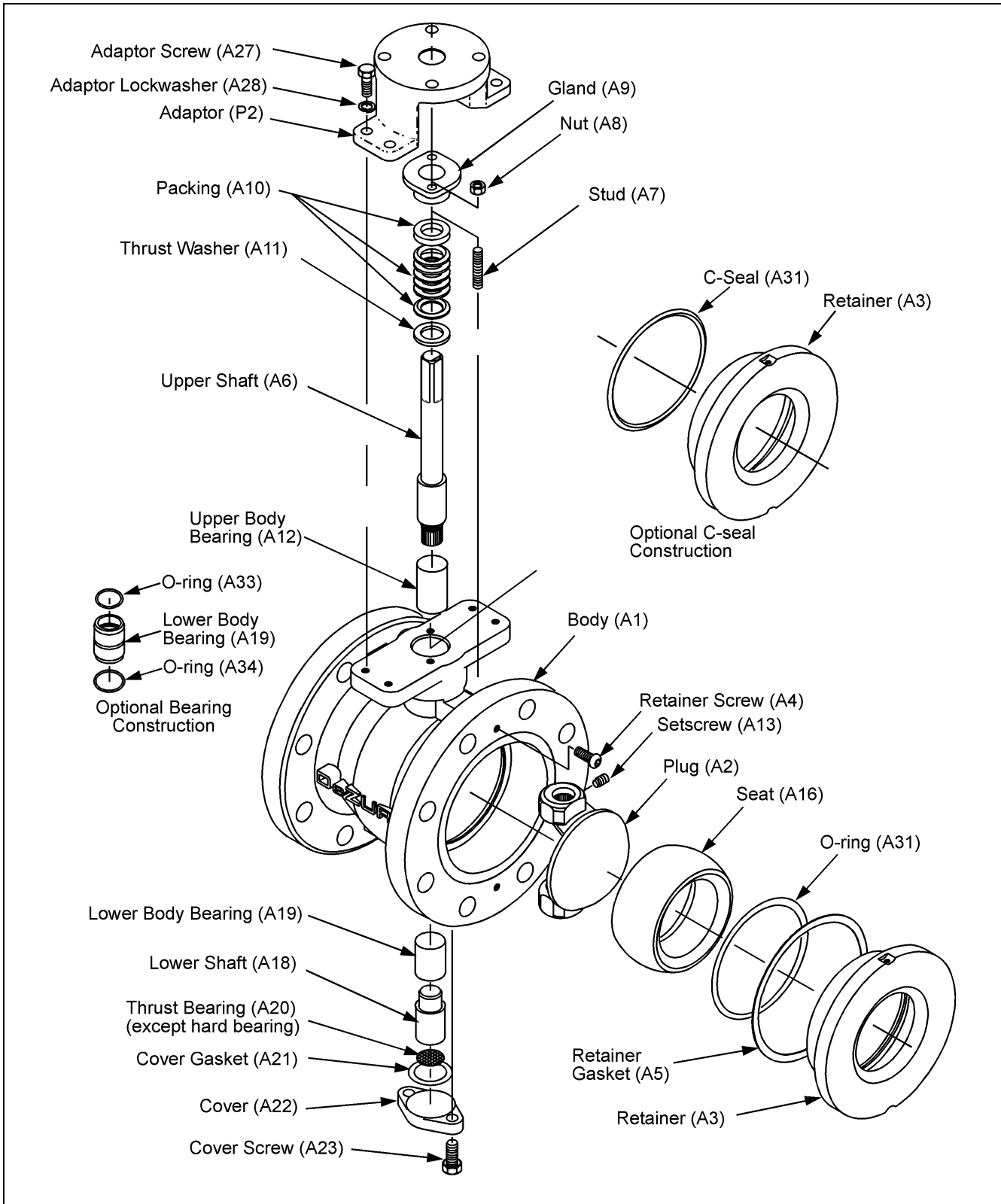

Figure 1 – Component Identification Disassembled

Drawings (Continued)

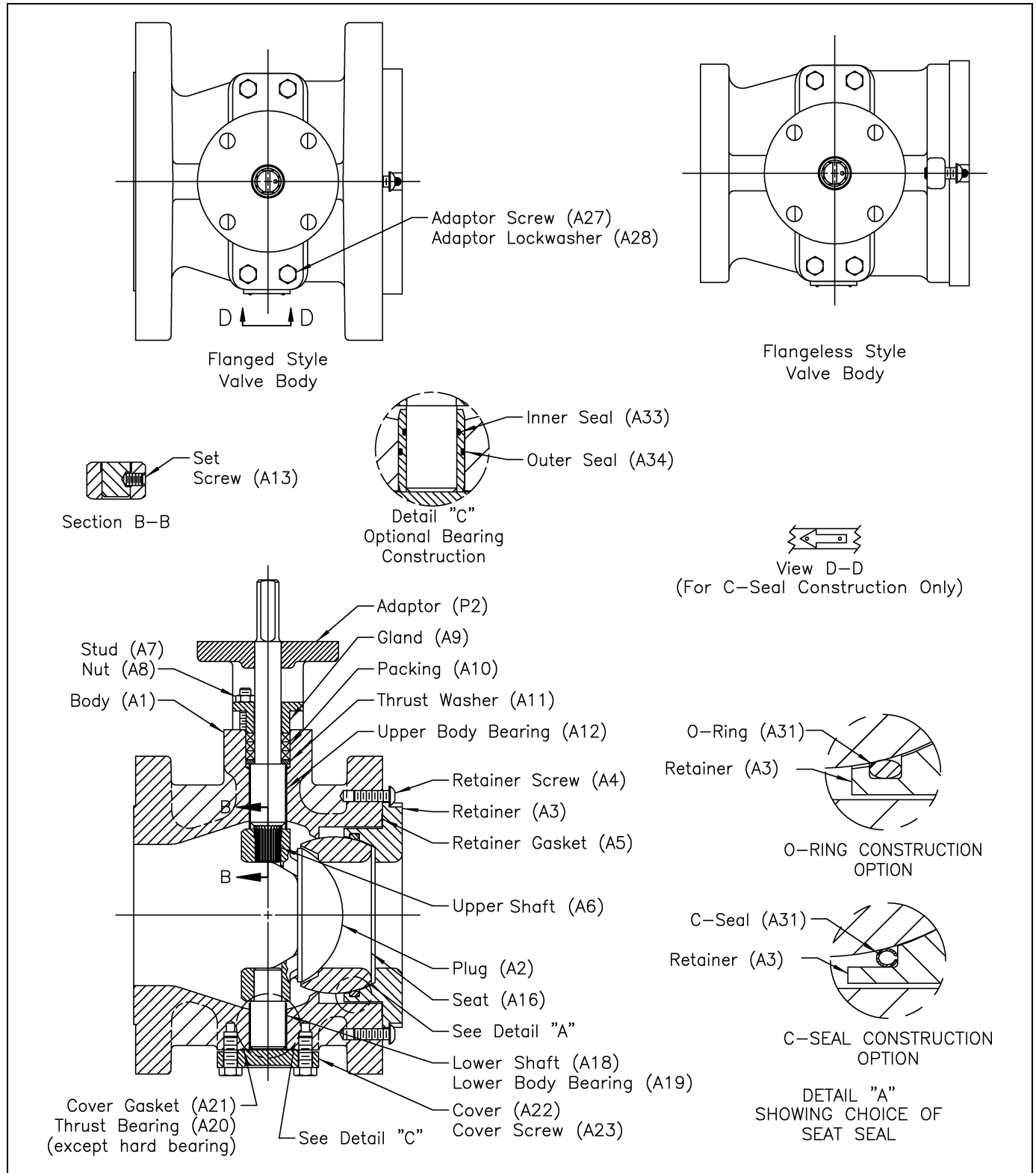

Figure 2 – Component Identification Assembled

Replacing Packing

See Figure 1 and Figure 2 for parts identification.



WARNING!

Pipeline pressure can cause personal injury or equipment damage. Relieve the pressure in the pipeline before removing the packing gland.

1. Discontinue flow and relieve pipeline pressure.



WARNING!

Accidental operation of powered actuator can cause personal injury or equipment damage. Disconnect and lock out power to actuator before servicing.

2. If the actuator is powered, disconnect and lock out the power to the actuator.
3. Remove the actuator from the valve as described in the Actuator Instructions.
4. Remove the adaptor screws (A27) and the adaptor (P2) from the body (A1).
5. Remove the gland nuts (A8) and the gland (A9) from the body.
6. Remove the used packing rings (A10) from the packing chamber in the body.
7. Place the new packing rings (A10) onto the upper shaft (A6), and slide rings into position in the packing chamber.

NOTE: If Graphoil Packing Option G2 (A10) is used, lubricate the inside and outside diameters of each packing ring with Krytox 240 AC lubricant (1068502).

8. Place the gland (A9) in position over the upper shaft (A6) and packing rings (A10), and replace the gland nuts (A8). Tighten the gland nuts finger tight, plus 1/2 turn.
9. Mount the adaptor (P2) on the body (A1) with screws (A27). See Table A for mounting screw torques:

Table A: Torques for Mounting Screws

Valve Size		Torque	
in	mm	ft lbs	Nm
1 - 2	25 - 50	12 ±2	16 ±2
2½" - 4	60 - 100	12 ±2	16 ±2
6 & 8	150 & 200	40 ±3	54 ±4
10 & 12	250 & 300	80 ±5	108 ±7

10. Mount the actuator on the valve as described in the Actuator Instructions.
11. Install the valve in the pipeline as described in the *Installing Valve* section.
12. The pipeline may now be pressurized. If packing leakage occurs, tighten the gland nuts (A8) evenly and slowly — just enough to stop the leakage.

Seat Replacement

See Figure 1 and Figure 2 for parts identification.



WARNING!

Pipeline pressure can cause personal injury or equipment damage. Relieve the pressure in the pipeline before removing flange bolts and flanges.

1. Relieve pressure in the pipeline and drain the pipeline.
-



WARNING!

Accidental operation of powered actuator can cause personal injury or equipment damage. Disconnect and lock out power to actuator before servicing.

2. If the actuator is powered, disconnect and lock out the power to the actuator.
3. Remove the flange bolting, and remove the valve from the pipeline.
4. Remove the two screws (A4), and remove the seat retainer (A3) and gasket (A5) from the body (A1).
5. Remove seat (A16).
6. Clean all gasket and/or seat material from the body and seat retainer.
7. Position the plug in the valve body so it is centered in the valve flow-way.
NOTE: The plug will be positioned at an angle.
8. Apply a light coat of media-compatible grease to the beveled edge of the seat that rests against the plug when assembled.
NOTE: When replacing a tungsten carbide seat, DeZURIK recommends replacing the plug and seat together as a matched set. In order to minimize seat leakage the plug and seat must be lapped together at the factory.
9. Place the seat (A16) into the valve body with the beveled side of the seat toward the plug. If a reduced trim seat with offset orifice is being installed, position the orifice in the 3 o'clock position as shown in Figure 3.
10. Rotate the plug toward the open position, then rotate the plug back toward the closed position until it just touches the complete circumference of the seat.
11. Place the seat retainer gasket (A5) in the body.
12. Place the seat retainer (A3) in the valve body with the timing mark, which is located on one of the retainer screw cutouts, toward the valve neck as shown in Figure 4.

DeZURIK

RCV Rotary Control Valves

Seat Replacement *(Continued)*

13. Apply a thread locking compound (removable type) to the retainer screw threads, and tighten the retainer screws (A4) finger tight.
14. Open the valve until the plug does not touch the seat, then rotate it back toward the closed position until the plug just touches the complete circumference of the seat.
15. Tighten the retainer screws (A4) evenly while allowing the seat to center on the closed plug.
16. Tighten the screws to the torques shown in Table B.

Table B: Torques for Retainer Screws

Valve Size		Torque	
in	mm	ft lbs	Nm
1 - 2	25 - 50	10 ±2	13 ±2
2½ - 4	60 - 100	12 ±2	16 ±2
6 & 8	150 & 200	16 ±2	22 ±2
10 & 12	250 & 300	40 ±3	54 ±4

Seat Replacement *(Continued)*

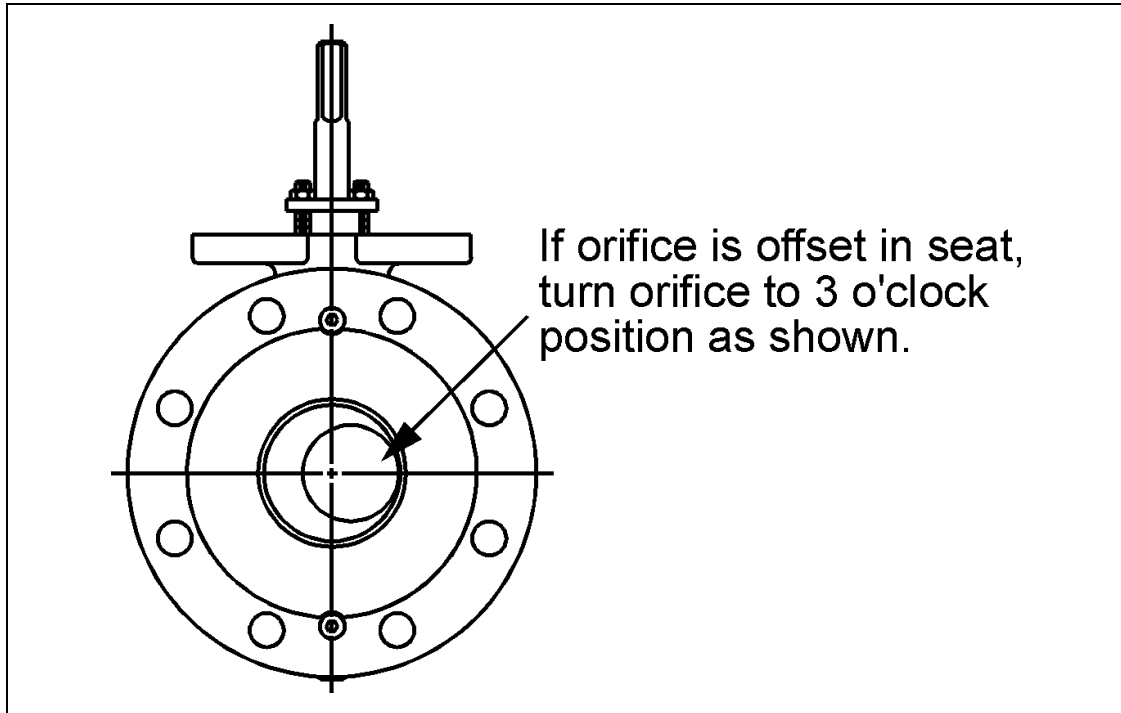

Figure 3 – Correct Position of Plug With Offset Orifice

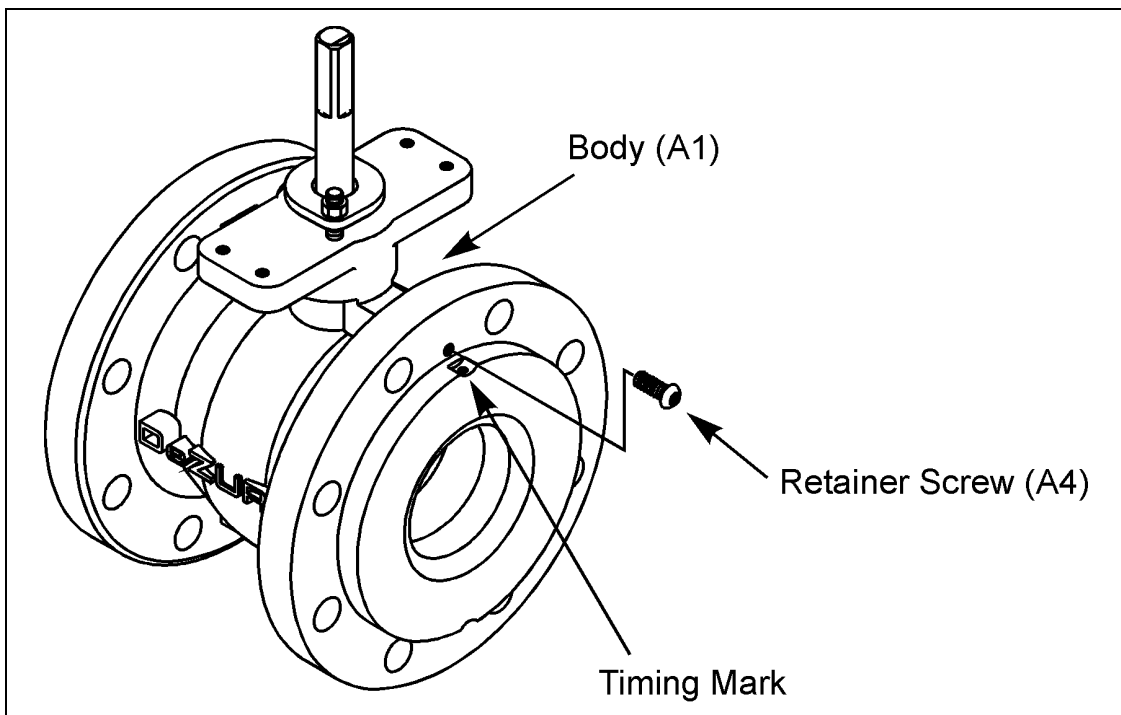

Figure 4 – Timing Mark Toward Valve Neck

Valve Disassembly

The valve may be disassembled and reassembled by following the steps in the next two sections. All parts should be inspected for wear, and worn parts should be replaced. Refer to Figures 1 and 2 for component identification.



WARNING!

Pipeline pressure can cause personal injury or equipment damage. Relieve the pressure in the pipeline before removing flange bolts and flanges.

1. Relieve the pressure in the pipeline, drain the pipeline and close the valve.
-



WARNING!

Accidental operation of powered actuator can cause personal injury or equipment damage. Disconnect and lock out power to actuator before servicing.

2. If the actuator is powered, disconnect and lock out the power to the actuator.
3. Remove the flange bolting, and remove the valve from the pipeline.
4. Remove the actuator from the valve as described in the Actuator Instructions.
5. Remove the adaptor screws (A27) and the adaptor (P2) from the body (A1).
6. Remove the two screws (A4), and remove the seat retainer (A3) and gasket (A5) from the body (A1).
7. Remove seat (A16).
8. With the plug in the open position, loosen and remove the set screw (A13) from the plug upper hub.
9. Remove the gland nuts (A8) and the gland (A9) from the body.
10. Remove the screws (A23), cover (A22), thrust bearing (A20) (if furnished), and gasket (A21) from the bottom of the body.
11. Remove the packing rings (A10) and thrust washer (A11) from the packing chamber in the body.
12. Remove the upper shaft (A6) and the lower shaft (A18) from the plug (A2) and body (A1).
13. Remove the plug (A2) through the seat side of the body (A1).
14. Remove the upper bearing (A12) and lower bearing (A19) from body (A1).
15. Clean all gasket material from the body and seat retainer. If the seal (A30) is to be replaced, remove the seal from the seat retainer.

Valve Reassembly

Clean and inspect all parts, and replace worn parts before reassembly. Refer to Figures 1 and 2 for component identification. The valve requires lubrication only when it is being assembled. Refer to the Actuator Instructions for lubrication requirements for the actuator.

1. Place the plug (A2) in the body (A1), with the splined hole toward the top of the valve.
2. Apply a light coat of media compatible grease to the inside and outside diameters, and to the ends of the lower solid bearing (A19).
 - a. If bearing has a fabric liner, the bearing does not require lubrication.
 - b. If bearing seals are required, place seal (A33) in the inner groove, and seal (A34) in the outer groove. Apply a light coat of media-compatible grease to the O-rings.
 - c. If bearing has seals, position bearing so inner seal is closest to plug.
3. Place the bearing into the lower body bore.
4. Insert the lower shaft (A18) through the shaft hole in the bottom of the body (A1), and into the hole in the plug (A2).
5. For valves that require a thrust bearing, apply a light coat of media-compatible grease to the flat sides of the thrust bearing (A20). If thrust bearing has a fabric side, the bearing does not require lubrication.
6. Place the thrust bearing (A20) against the bottom of the lower shaft (A18). If thrust bearing has a fabric side, fabric side must face the shaft.
7. Apply a light coat of anti-seize compound to the threads of the screws (A23).
8. Place the gasket (A21) and the cover (A22) on the bottom of the body (A1). Fasten the cover with screws (A23).
 - For valve sizes 1 - 2" (25–50mm), tighten the 1/4" screws to 10 ±2 ft lbs (13 ±2 Nm).
 - For valve sizes 2-1/2 - 6" (60–50 mm), tighten the 3/8" screws to 16 ±2 ft lbs (22 ±2 Nm).
 - For valve sizes 8 – 12" (200-300mm), tighten the 1/2" screws to 40 ±3 ft lbs (54 ±4 Nm).
9. Apply a light coat of media-compatible grease to the inside and outside diameters of the upper solid bearing (A12).
 - If bearing has a fabric liner, the bearing does not need lubrication.
 - If bearing seals are required, place seal (A33) in the inner groove, and seal (A34) in the outer groove. Apply a light coat of media-compatible grease to the O-rings.
 - If bearing has seals, position bearing so inner seal is closest to plug.
10. Place the upper bearing into the upper body bearing bore.
11. Apply a light coat of media-compatible grease to the valve shaft (A6) splines.
12. Insert the upper shaft (A6) through the bearing located in the upper body bearing bore, and into the splined hole in the plug (A2), making sure the threaded hole in the upper plug hub is in line with the recessed hole located in the shaft spline area. Push the upper shaft downward into the valve body until all axial movement is taken up.

DeZURIK

RCV Rotary Control Valves

Valve Reassembly (Continued)

13. Position the plug in the valve body so it is centered in the valve flow-way.

NOTE: The plug will be positioned at an angle in the body.

14. Place the seat (A16) into the bore of the body (A1) with the beveled side of the seat toward the plug.

15. Rotate the plug (A2) toward the open position, then rotate the plug back toward the closed position until it just makes contact with the complete circumference of the seat. Do not rotate valve shaft any farther once the plug touches the seat circumference.

16. Note position of the shaft square in relation to body flange face.

- The shaft square should be parallel with valve flange face as shown in Figure 5A (Preferred for all actuators), or angled slightly as shown in Figure 5B (All actuators except Reverse acting (spring-to-close) Diaphragm actuators) or: Figure 5C (Reverse acting (spring-to-close) Diaphragm actuators only).
- If the valve shaft square is not oriented as in Figure 5A or 5B, remove the shaft from the plug spline, rotate the shaft until the correct position is achieved, then insert the shaft spline into the splined hole in the plug.

NOTE: If Graphoil Packing Option G2 (A10) is used, lubricate the inside and outside diameters of each packing ring with Krytox 240 AC lubricant (1068502).

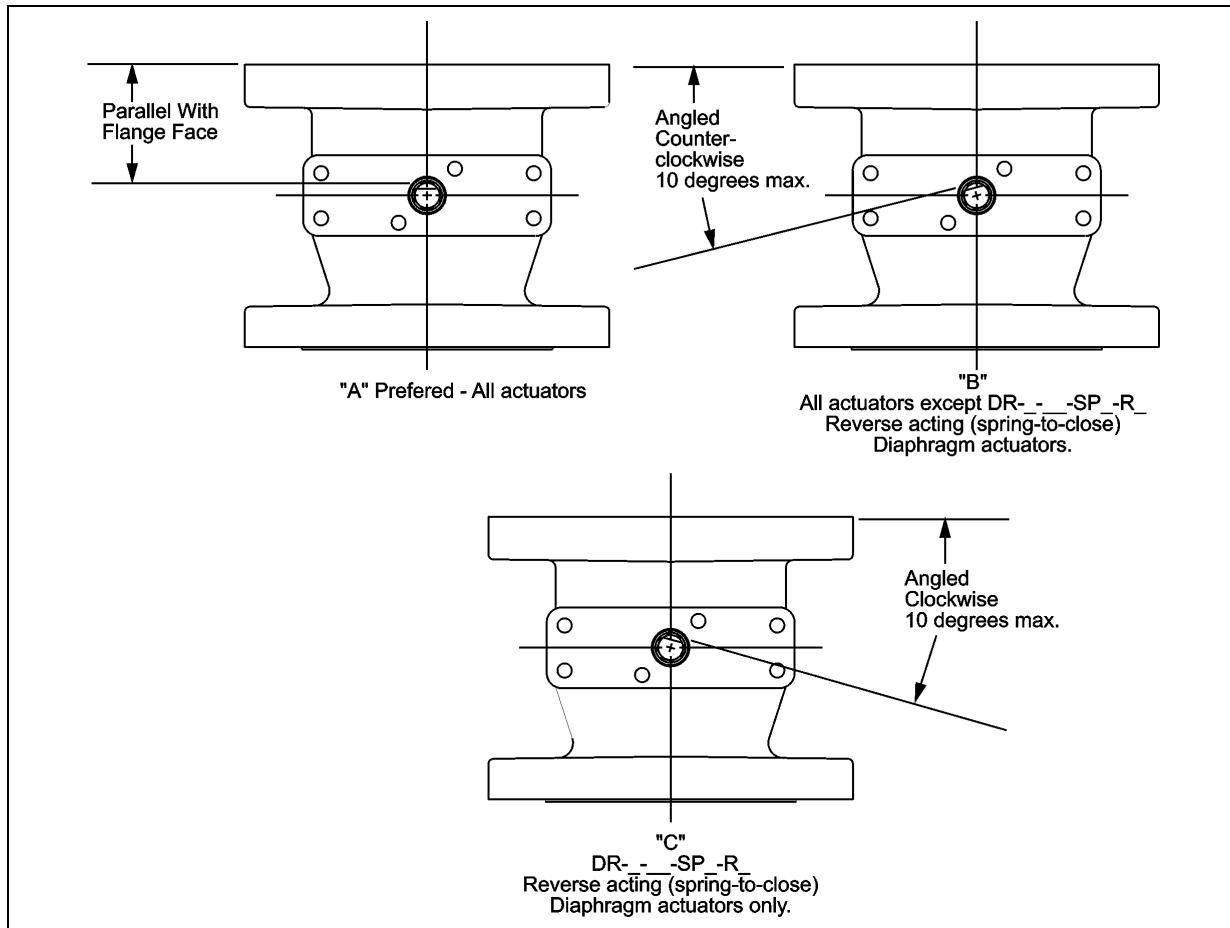

Figure 5 – Shaft Square Must Be Parallel with Valve Flange Face or Angled Slightly As Directed.

Valve Reassembly *(Continued)*

17. Apply a light coat of media compatible, anti-seize compound to the setscrew (A13).
18. With the plug in the open position, install the setscrew (A13) into the plug upper hub, and tighten to the torque specified in Table D.

Table D: Torques for Setscrews

Valve Size		Torque	
in	mm	ft lbs	Nm
1 - 2	25 - 50	6 ±1	8 ±1
2½" - 4	60 - 100	10 ±2	13 ±2
6	150	12 ±2	16 ±2
8	200	16 ±2	22 ±2
10 & 12	250 & 300	18 ±2	24 ±2

19. Stake the set screw in the plug hub to secure it in place.
20. Mount the adaptor (P2) on the body (A1) with screws (A27) and lockwasher (A28), and tighten to the torque shown in Table E.
21. Mount the actuator on the valve as described in the Actuator Instructions.
22. Place the seal (A31) into the cavity in the seat retainer (A3), and apply a light coat of media-compatible grease to the seal.

NOTE: If a metal "C" seal is used, insert the seal so the gap in the seal faces the retainer. See Figure 2, detail "A."

Table E: Torques for Mounting Screws

Valve Size		Torque	
in	mm	ft lbs	Nm
1 - 2	25 - 50	12 ±2	16 ±2
2½" - 4	60 - 100	12 ±2	16 ±2
6 & 8	150 & 200	40 ±3	54 ±4
10 & 12	250 & 300	80 ±5	108 ±7

23. Install the seat (A16) and seat retainer (A3) as described in the SEAT REPLACEMENT section.
24. Set the closed position stop as described in the ACTUATOR CLOSED POSITION STOP ADJUSTMENT section.
25. Install the valve in the pipeline as described in the INSTALLATION section of these instructions.
26. If the actuator is a powered actuator, reconnect power to the actuator.
27. The pipeline may now be pressurized. Once pressurized, verify that the valve is sealing properly.
 - a. If seat leakage occurs, adjust the closed position stop until seat leakage stops.
 - b. If packing leakage occurs, tighten the gland nuts (A8) evenly and slowly, just enough to stop leakage.

Actuator Closed Position Stop Adjustment

1. Open the valve until the plug does not touch the seat, then move the plug toward the closed position until the plug just touches the complete circumference of the seat.
2. Turn the closed position stop screw clockwise until resistance is felt, then turn the stop screw counterclockwise one half turn. While holding the stop screw from turning, tighten the jam nut to the torque listed in the actuator instructions.
3. To adjust the open position stop, see the actuator instructions.
4. Install the valve in the pipeline as described in the INSTALLATION section of these instructions.
5. If the actuator is a powered actuator, reconnect power to the actuator.
6. The pipeline may now be pressurized. Once pressurized, verify that the valve is sealing properly.
 - a. If seat leakage occurs, adjust the closed position stop until seat leakage stops.
 - b. If packing leakage occurs, tighten the gland nuts (A8) evenly and slowly, just enough to stop the leakage.

Troubleshooting

Condition	Possible Cause	Corrective Action
Packing leaks.	Packing is loose.	Adjust packing gland.
	Packing is worn.	Replace packing.
Valve leaks when fully closed.	Seat is worn.	Replace seat.
Valve leaks when fully closed, and plug is galled.	Plug is worn or galled.	Replace plug and seat.
Valve body leaks from body joint.	Pipeline flange bolting is loose.	Tighten pipeline flange bolts or studs.
	Gasket is worn.	Replace gasket(s).
Opening/closing torque is excessive.	Bearings, shafts, plug, and/or seat are worn.	Replace worn part(s).

Limited Warranty

DeZURIK, Inc. ("Seller") manufactured products, auxiliaries and parts for a period of twenty-four (24) months from date of shipment from Seller's factory, are warranted to the original purchaser only against defective workmanship and material, but only if properly stored, installed, operated, and serviced in accordance with Seller's recommendations and instructions.

For items proven to be defective within the warranty period, your exclusive remedy under this limited warranty is repair or replacement of the defective item, at Seller's option, FCA Incoterms 2020 Seller's facility with removal, transportation, and installation at your cost.

Products or parts manufactured by others but furnished by Seller are not covered by this limited warranty. Seller will provide repair or replacement for other's products or parts only to the extent provided in and honored by the original manufacturer's warranty to Seller, in each case subject to the limitations contained in the original manufacturer's warranty.

No claim for transportation, labor, or special or consequential damages or any other loss, cost or damage is being provided in this limited warranty. You shall be solely responsible for determining suitability for use and in no event shall Seller be liable in this respect.

This limited warranty does not warrant that any Seller product or part is resistant to corrosion, erosion, abrasion or other sources of failure, nor does Seller warrant a minimum length of service.

Your failure to give written notice to us of any alleged defect under this warranty within twenty (20) days of its discovery, or attempts by someone other than Seller or its authorized representatives to remedy the alleged defects therein, or failure to return product or parts for repair or replacement as herein provided, or failure to store, install, or operate said products and parts according to the recommendations and instructions furnished by Seller shall be a waiver by you of all rights under this limited warranty.

This limited warranty is voided by any misuse, modification, abuse or alteration of Seller's product, accident, fire, flood or other Act of God, or your failure to pay entire contract price when due.

The foregoing limited warranty shall be null and void if, after shipment from our factory, the item is modified in any way or a component of another manufacturer, such as but not limited to, an actuator is attached to the item by anyone other than a Seller factory authorized service personnel.

All orders accepted shall be deemed accepted subject to this limited warranty, which shall be exclusive of any other or previous Warranty, and this shall be the only effective guarantee or warranty binding on Seller, despite anything to the contrary contained in the purchase order or represented by any agent or employee of Seller in writing or otherwise, notwithstanding, including but not limited to implied warranties.

THE FOREGOING REPAIR AND REPLACEMENT LIMITED WARRANTY IS IN LIEU OF ALL OTHER WARRANTIES, OBLIGATIONS AND LIABILITIES, INCLUDING ALL WARRANTIES OF FITNESS FOR A PARTICULAR PURPOSE OR OF MERCHANTABILITY OR OTHERWISE, EXPRESSED OR IMPLIED IN FACT OR BY LAW, AND STATE SELLER'S ENTIRE AND EXCLUSIVE LIABILITY AND YOUR EXCLUSIVE REMEDY FOR ANY CLAIM IN CONNECTION WITH THE SALE AND FURNISHING OF SERVICES, GOODS OR PARTS, THEIR DESIGN, SUITABILITY FOR USE, INSTALLATION OR OPERATIONS.

Disclaimer

Metric fasteners should not be used with ASME Class 150/300 bolt holes and flange bolt patterns. If you use metric fasteners with ASME Class 150/300 bolt holes and flange bolt patterns, it may lead to product failure, injury, and loss of life. DeZURIK Inc. disclaims all liability associated with the use of metric fasteners with ASME Class 150/300 bolt holes and flange patterns, including but not limited to personal injury, loss of life, loss of product, production time, equipment, property damage, lost profits, consequential damages of any kind and environment damage and/or cleanup. Use of metric fasteners with ASME Class 150/300 bolt holes and flange bolt patterns is a misuse that voids all warranties and contractual assurances. If you use metric fasteners with ASME Class 150/300 bolt holes and flange bolt patterns, you do so at your sole risk and any liability associated with such use shall not be the responsibility of DeZURIK, Inc. In addition to the foregoing, DeZURIK's Manufacturer's Conditions apply.

Limitation of Liability

IN NO EVENT SHALL SELLER BE LIABLE FOR ANY DIRECT, INDIRECT, SPECIAL, PUNITIVE, OR CONSEQUENTIAL DAMAGES WHATSOEVER, AND SELLER'S LIABILITY, UNDER NO CIRCUMSTANCES, WILL EXCEED THE CONTRACT PRICE FOR THE GOODS AND/OR SERVICES FOR WHICH LIABILITY IS CLAIMED. ANY ACTION FOR BREACH OF CONTRACT BY YOU, OTHER THAN RIGHTS RESPECTING OUR LIMITED WARRANTY DESCRIBED ABOVE, MUST BE COMMENCED WITHIN 12 MONTHS AFTER THE DATE OF SALE.

Sales and Service

For information about our worldwide locations, approvals, certifications and local representative:

Web site: www.dezurik.com E-Mail: info@dezurik.com



250 Riverside Ave. N., Sartell, MN 56377 • Phone: 320-259-2000 • Fax: 320-259-2227

DeZURIK, Inc. reserves the right to incorporate our latest design and material changes without notice or obligation. Design features, materials of construction and dimensional data, as described in this manual, are provided for your information only and should not be relied upon unless confirmed in writing by DeZURIK, Inc. Certified drawings are available upon request.