

DeZURIK BOS-US 24-36" UNINTERRUPTED SEAT RESILIENT SEATED BUTTERFLY VALVES

Design and Applications

BOS-US 24–36" (600–900mm) Resilient-Seated Butterfly Valves are designed to handle a wide variety of liquids and gases, including water, air, petroleum, and noncorrosive chemicals. BOS-US Valves are extensively used in hot-process applications, in mining operations, in paper mills, and in environments requiring up to 28"-Hg (710mm-Hg) of vacuum. In thousands of installations worldwide, DeZURIK BOS-US Valves have a proven record of long-term reliability, throttling control, value-added design features and unmatched economy.

Lugged & Wafer Body Styles

BOS-US Valves are available in lugged or wafer body styles. Flangeless bodies reduce weight and ease of installation. They have four drilled-and-tapped flange bolt holes on either side of the body to center the valve in the pipeline. Lugged body valves have two drilled-and-tapped flanges to provide tight shut-off in isolation and dead-end service without the use of downstream flanges. The one-piece body wall thickness meets or exceeds the ASME Class 125 standard for cast iron flanges and fittings. Body wall thickness also exceeds the AWWA Class 150B standard for butterfly valves. BOS-US Valves are available with flanges drilled to ASME 125/150 standards or to comply with ISO, DIN, BS or JIS bolt patterns.

Choice of Seat Materials

Standard BOS-US seat options include Acrylonitrile-Butadiene (NBR) and Chloroprene (CR). Also available are Urethane (EU) for abrasive slurries; Terpolymer of Ethylene Propylene & a Diene (EPDM) for water and elevated temperature applications, and Fluoro Rubber (FKM).



Offset Disc, 360° Seating

By using an offset disc and a shaft centered in the valve body, BOS-US Valves offer improved seating performance and better throttling control. This uninterrupted 360° seating design minimizes seat wear and leads to longer valve life. A thrust bearing on the bottom of the shaft ensures proper disc-to-seat alignment and absorbs shaft thrust regardless of the valve's mounting position. Offset discs help sweep solids from the seat area, providing positive sealing, even when throttling viscous materials. Disc options include a ductile iron disc with a welded and machined nickel edge that meets AWWA C504 standards. Corrosion resistant 316 stainless steel or bronze discs are also available.

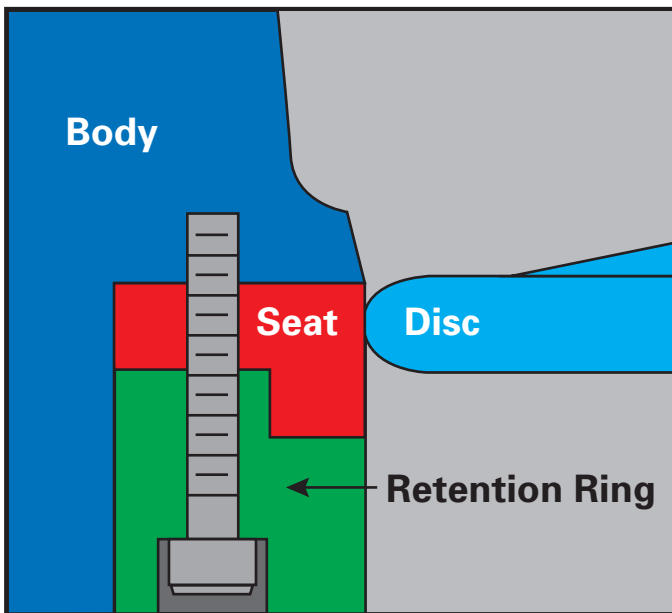

Seat Retention Ring

The resilient seat is bonded to a metal retention ring held in place by stainless steel retaining screws to allow seat adjustment. The design of the seat and ring eliminates scalloping, excessive disc-to-seat interference and seat wear.

Protected Seat Design

Adding to the benefits of using an offset disc and an uninterrupted 360° resilient sealing surface, BOS-US Valves feature seats that are protected from foreign objects in the line. The seat is nearly flush with the inside diameter of the valve, protecting it from abrasive and mechanical damage. BOS-US Valves have bi-directional, zero-leakage shutoff to 175 psi (1210 kPa) CWP pressure differential, with pressure on either side of the disc.

Long-Life Stem Seal

Adjustable multiple-ring packing provides a reliable seal that seldom, if ever, needs to be adjusted or replaced. The packing and the packing gland are accessible without valve disassembly or actuator removal.

Solid, One-Piece Shaft

The stainless steel valve shaft is ground and polished to minimize bearing and seal wear. The shaft is in constant contact with the disc to maximize strength and rigidity. The shaft diameter meets AWWA Class 75B standards. Fiber-reinforced PTFE bearings prevent corrosion and ensure smooth and reliable operation.

Rigid Disc-to-Shaft Pinning

To ensure a rigid, long-life connection between the shaft and the disc, stainless steel tangential pins with tapered flats are positioned against matching flats on the valve shaft. Contact between the pins and shaft allows axial shaft expansion without disc damage. The pinning is solid — there are no holes drilled through the disc or shaft to weaken the connection or cause leakage. Specially machined 4° locking taper pins ensure no lost motion in the critical disc-to-shaft connection, which is important for accurate throttling control. The tangential pins are retained by threaded plugs.

Actuators & Accessories

DeZURIK's proven G-series gear-drive actuators are available with handwheel, chainwheel or 2" square nut inputs in weatherproof or buried/submerged construction. BOS-US Valves are also available with pneumatic or hydraulic cylinders and electric motor actuators. A full line of accessories is available including positioners, solenoids, switches, speed controls, extensions and floor stands.

Materials of Construction

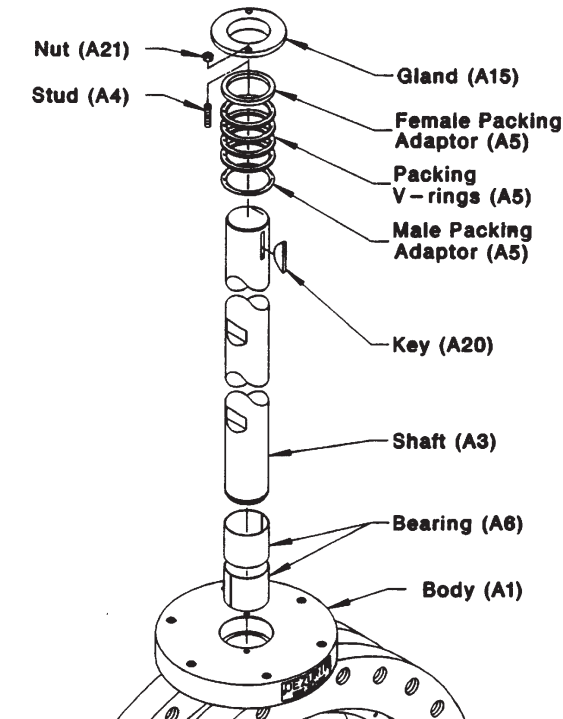

Item	Description	Material
A1	Body	Cast Iron, ASTM A126 Class B
A2	Disc	Ductile Iron , ASTM A536, 65-45-12 316 Stainless Steel, ASTM A743, Grade CF8M Bronze, ASTM B584/B763, Grade C84400
A3	Shaft	316 Stainless Steel, ASTM A276 416 Stainless Steel, ASTM A582
A4	Stud	18-8 Stainless Steel
A5	Packing	NBR, Acrylonitrile-Butadiene PTFE, V-Flex
A6	Bearing	Fiber Reinforced PTFE
A7	Thrust Bearing	PTFE with 304 Stainless Steel backing
A8	Retaining Ring	302 Stainless Steel
A9	Spring	302 Stainless Steel
A10	Thrust Bearing	PTFE with 304 Stainless Steel backing
A11	O-Ring	NBR, Acrylonitrile-Butadiene FKM, Fluoro Elastomer
A12	Cover	Steel, ASTM A36
A13	Screw	Steel, Zinc Plated
A14	Thrust Bearing	18-8 Stainless Steel
A15	Gland	Cast Iron, ASTM A126 Class B
A16	Pin	304 Stainless Steel, ASTM A276
A17	Set Screw	304 Stainless Steel, ASTM A276
A18	Screw	18-8 Stainless Steel
A19	Seat Ring	NBR, Acrylonitrile-Butadiene
		CR, Chloroprene
		EPDM, Terpolymer of Ethylene Propylene & a Diene
		FKM, Fluoro Elastomer
	Base Material	Bronze, ASTM B584/B763
A20	Key	Alloy Steel
A21	Locknut	18-8 Stainless Steel

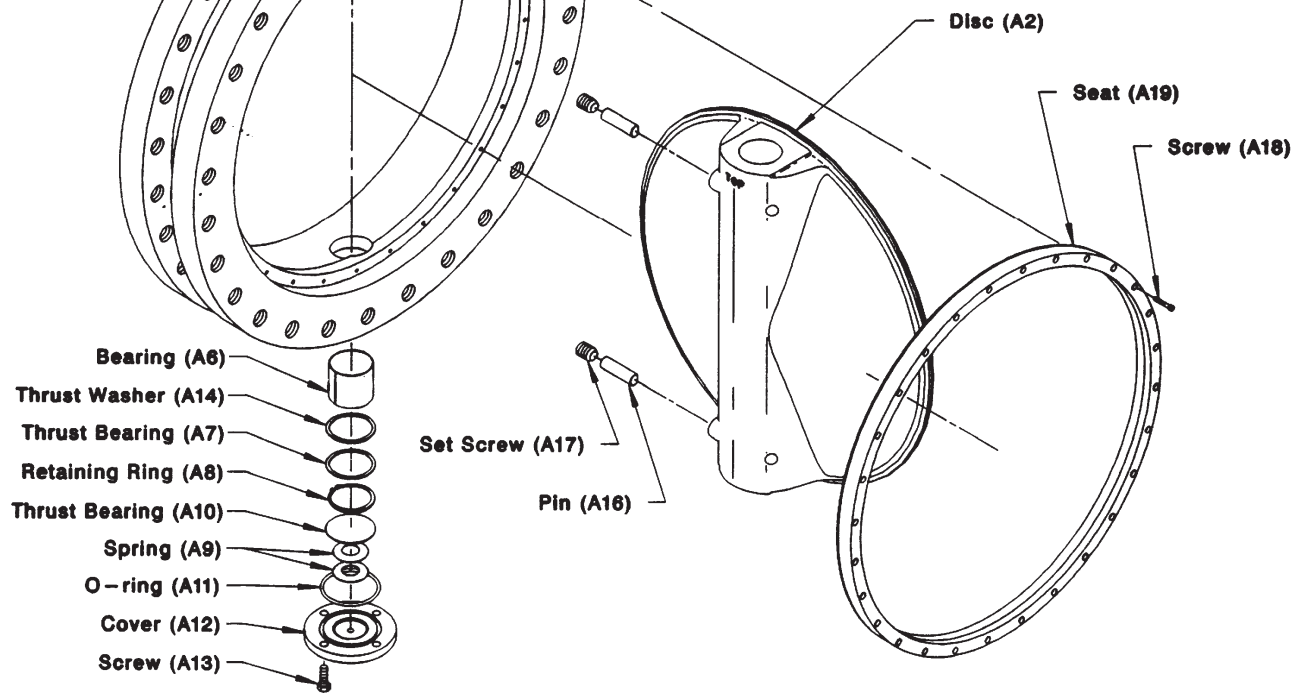

Valve Selection

Shut-Off Capabilities

All Seat Materials	Bubble Tight Shutoff
--------------------	----------------------

Full rated bi-directional shutoff; lugged valves provide dead end service to full valve rating.

Pressure Ratings (Ambient Temperatures)

Valve Size	Pressure Rating
All 24-36" valves	175 psi (1210 kPa) CWP pressure differential in either direction.

Temperature Ratings

Seat Material	Temperature Rating
NBR = Acrylonitrile-Butadiene	10 to 180°F (-12 to 82°C)
CR = Chloroprene	180°F (82°C)
EPDM = Terpolymer of Ethylene Propylene & a Diene	-30 to 250°F (-35 to 121°C)
FKM = Fluoro Elastomer	10 to 300°F (-12 to 150°C)
EU = Polyether Urethane Seat	130°F (54°C)

Pipeline Velocity Range

All 24-36" valves	Up to 16 feet/second (5 meters/second)
-------------------	--

Contact DeZURIK for pipeline velocities greater than 16 feet/second

Applicable Standards

DeZURIK BOS-US Valves are designed and/or tested to meet the following standards:	
ASME B16.1	Conforms to Class 125 flange drilling.
ASME B16.5	Conforms to Class 150 flange drilling.
ASME B16.104	Exceeds Class VI shutoff requirements.
AWWA C504	Diameter of stainless steel shaft meets AWWA Class 75B standard. Body wall thickness exceeds the AWWA Class 150B standard for butterfly valve.
MSS SP-25	Markings and identification conform to the requirements.
International	Metric flange drilling (W110 and L110) = ISO 7005-2, DIN or BS4504 PN10 Drilling Flange Drilling Metric flange drilling (W116 and L116) = ISO 7005-2, DIN or BS4504 PN16 Drilling

Valve Weights

Valve Size	Basic Valve		Add For Bronze Disc
	Wafer	Lugged	
24" 600mm	640 291	795 361	35 16
30" 750mm	990 450	1335 606	75 35
36" 900mm	1585 720	2125 965	135 62

Flow Parameters

Valve Size	Cv* Kv*
24" 600mm	23100 20000
30" 750mm	37200 32200
36" 900mm	53300 46100

*Cv = Flow in GPM of water at 1 psi pressure drop.
Kv = Flow in m3/hr. of water at 100 kPa pressure drop.

Percent Open vs Percent Flow

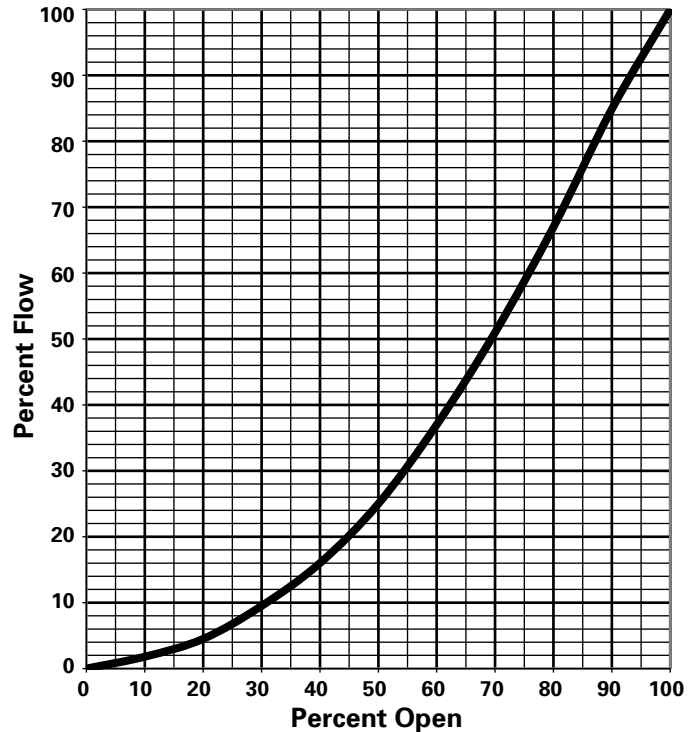

Ordering

To order, simply complete the valve order code from information shown. An ordering example is shown for your reference.

Valve Style Give valve style code as follows: BOS = Resilient-Seated Butterfly Valve

Valve Size Give valve size code as follows: 24 = 24" (600mm) 30 = 30" (750mm) 36 = 36" (900mm)

Body Style Give body style code as follows: US = Uninterrupted Seat
--

End Connection Give end connection code as follows: Wafer W1 = ASME Class 125/150 Wafer Drilling W110 = ISO 7005-2, DIN or BS4504 PN10 Drilling W116 = ISO 7005-2, DIN or BS4504 PN16 Drilling W1J1 = JIS10 Drilling W1DA = AS2129 Table "D" Drilling W1EA = AS2129 Table "E" Drilling W1D = BS Table "D" Drilling W1E = BS Table "E" Drilling Lugged L1 = ASME Class 125/150 Lugged Drilling L110 = ISO 7005-2, DIN or BS4504 PN10 Drilling L116 = ISO 7005-2, DIN or BS4504 PN16 Drilling L1J1 = JIS10 Drilling L1DA = AS2129 Table "D" Drilling L1EA = AS2129 Table "E" Drilling L1D = BS Table "D" Drilling L1E = BS Table "E" Drilling

NOTE: Other special drilling on application.

Body Material Give body material code as follows: CI = Cast Iron DI = Ductile Iron
--

Seat and Shaft Seal Material Combination Give material code as follows: NBR,NBR = Acrylonitrile-Butadiene Seat and Shaft Seal 10° to 180°F (-12 to 82°C) CR,NBR = Chloroprene Seat, 180°F (83°C) Acrylonitrile-Butadiene Shaft Seal, 10° to 180°F (-12 to 82°C) EPDM,T = Terpolymer of Ethylene Propylene & a Diene Seat, -30° to 250°F (-35 to 121°C) PTFE Shaft Seal, 500° F (260°C) FKM,T = Fluoro Rubber Seat, 10° to 300°F (-12 to 150°C) PTFE Shaft Seal, 500° F (260°C) EU,T = Polyether Urethane Seat, 130° F (54°C) PTFE Shaft Seal, 500° F (260°C)

NOTE: The limiting factor in valve selection is the lowest temperature rating of the seat or shaft seal material.

Trim Combination Give Disc-Shaft material code as follows: DI-S4 = Ductile Iron Nickel Welded Disc 416 Stainless Steel Shaft S2-S2 = 316 Stainless Steel Disc 316 Stainless Steel Shaft BZ-S4 = Bronze Disc 416 Stainless Steel Shaft
--

Options Give option code as follows: CMC = Certificate of Material Conformance DTR = DeZURIK Standard Certified Production Hydrostatic Shell & Seat Test Report

Ordering Example:

BOS,30,US,W1,CI,NBR,NBR,DI-S4*actuator

Dimensions

Lugged

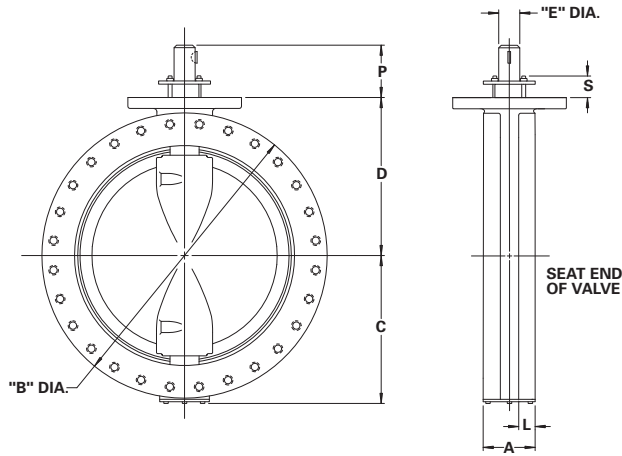

Wafer

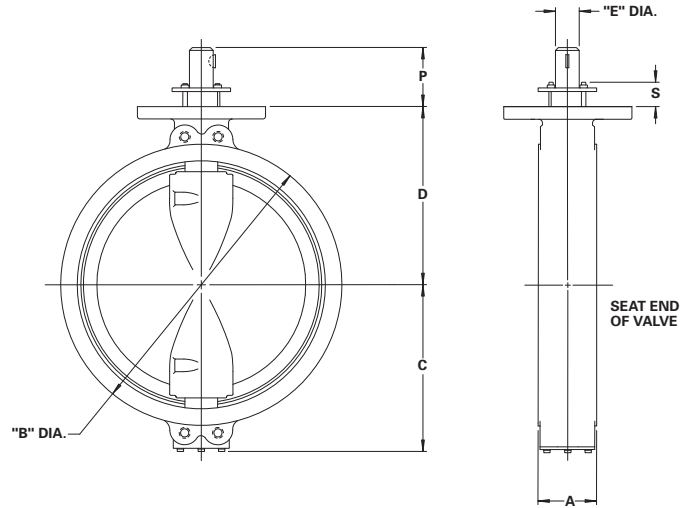

Valve Size	Dimensions								
	A	B		C	D	E	L	P	S
		Lugged	Wafer						
24" 600mm	6.25 159	32.00 813	26.50 673	17.62 448	20.00 508	2.50 64	2.00 51	6.62 168	1.50 38
30" 750mm	7.38 187	38.75 984	33.00 838	20.38 518	21.88 556	3.00 76	2.25 57	6.62 168	1.38 35
36" 900mm	9.00 229	46.00 1168	39.50 1003	24.12 613	26.25 667	3.62 92	2.69 68	6.62 168	1.38 35

Sales and Service

For information about our worldwide locations, approvals, certifications and local representative:

Web Site: DeZURIK.com E-Mail: info@DeZURIK.com



250 Riverside Ave. N. Sartell, Minnesota 56377 • Phone: 320-259-2000 • Fax: 320-259-2227

DeZURIK, Inc. reserves the right to incorporate our latest design and material changes without notice or obligation. Design features, materials of construction and dimensional data, as described in this bulletin, are provided for your information only and should not be relied upon unless confirmed in writing by DeZURIK, Inc. Certified drawings are available upon request.