



**DeZURIK KGC-ES
EXTENDED SERVICE LIFE
CAST STAINLESS STEEL
KNIFE GATE VALVES**



DeZURIK KGC-ES (Extended Service Life) Cast Stainless Steel Knife Gate Valves

Applications

DeZURIK KGC-ES Cast Stainless Steel Knife Gate Valves are designed for the toughest corrosive, abrasive liquid, slurry or dry material applications including: Pulp and Paper, Mining, Waste Water, Chemical, Petrochemical, Power, Steel, Food Processing, etc.

Design and Construction

The heart of the KGC-ES is the DeZURIK **Exclusive Premium Packing System**. This system features a tight tolerance machined packing chamber, rounded gate edge, Anti-Extrusion Ring, and many packing options to meet the demands of your specific application. All of these features together will improve sealing, extend packing life, and reduce maintenance.

Depending on what your application requires, the cast body and packing gland are available in 304, 316, 317, 254-SMO, 2205 Duplex Stainless Steel or Hastelloy C 276. Other body and gate materials are available upon request.

KGC-ES Knife Gate Valves are available in sizes 2" - 48" (50mm - 1200mm) with metal or resilient seated versions.

The actuator superstructure is heavy duty cast carbon steel or cast stainless steel to minimize corrosion. A variety of actuator options are available including: handwheels, chainwheels, bevel gears, levers, pneumatic cylinders, hydraulic cylinders, and electric motors. A full complement of accessories is also offered.

Applicable Standards

DeZURIK KGC-HD Knife Gate Valves are designed and/or tested to meet the following standards:	
MSS SP-81 Metal Seated Valves	Stainless Steel, Bonnetless, Flanged Knife Gate Valves
ANSI B16.5 2" - 24" (50 - 600mm)	Carbon Steel Flanges and Flanged Fittings, ANSI 150. Conforms to related drilling dimensions
ANSI 16.47 26" - 48" (650 - 1200mm)	Large diameter Steel Flanges. Series A. Conforms to related dimensions.
ASME B16.20 2" - 48" (50 - 1200mm)	Metallic Gaskets for Pipe Flanges. Conforms to Spiral-Wound gasket dimensions
International Standards	Conforms to flanged bolt guides: JIS 10; DIN 10 and DIN 16; ISO 7005-1/PN10 and 7005-2/PN16; BS 4504/PN10 and BS 4504/PN16; and AS 2129 Tables D and E; SANS 1123-1000 and SANS 1123-1600



DeZURIK Exclusive Rounded Stainless Steel Gate

Gates are available in 304, 316, 317, 17-4, 254-SMO, 410, 2205 Duplex Stainless Steel or Hastelloy C for corrosion resistance. The gate has a precision ground finish on both sides to prevent packing and seat damage. The beveled knife-like gate edge with machined tooth on each side pushes away or cuts through solids in the flow stream.

- Provides superior sealing
- Improves packing life
- Requires less compression and thus reduces friction
- Eliminates sharp corners where leakage first occurs

Cast Gate Guides and Jams

The cast gate guides provide support for the moving gate and will not break off like welded guides. Cast gate jams at the bottom of the body hold the gate securely against the seat to assure positive shutoff. All KGC-ES valves can handle full reverse pressure without damage. The body has raised face end connections with drilled and tapped lugs.

High Flow Capacity

100%, round port design allows high flow capacity and minimum pressure drop. DeZURIK's KGC-ES valve seat I.D. is equal to the inside diameter of standard pipe (ASME B36.10).

Full Gasket Sealing Front and Back

For maximum gasket sealing the KGC-HD end connections conform to ASME B16.20 dimensions for Spiral-Wound gaskets.

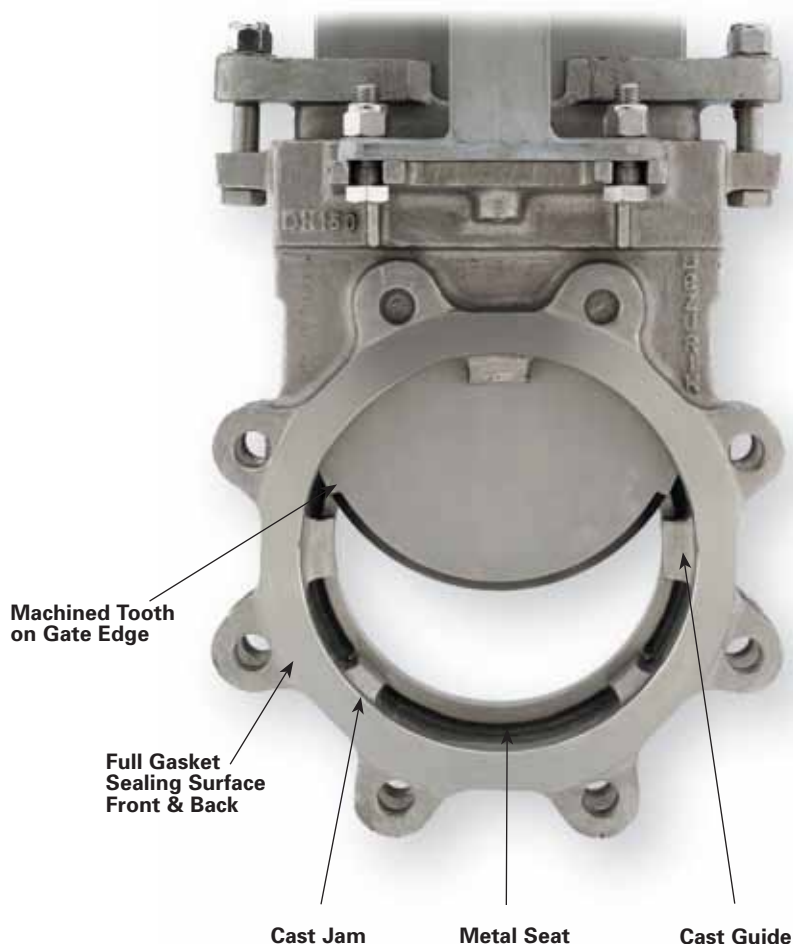

DeZURIK Exclusive Premium Packing System Ensures Long-Life by Sealing, Scraping and Supporting

DeZURIK KGC-ES Valves have a unique packing system that ensures a long-life tight seal with minimal packing gland pressure. The Premium Packing System is available for general, moderate, severe, and high temperature applications. The machined packing chamber, rounded gate edge, and Anti-Extrusion Ring form the base. The system is completed by careful selection of the packing material. Temperature, pH, and media properties will determine the most suitable packing option. KGC-ES valves can be re-packed without being removed from the pipeline.

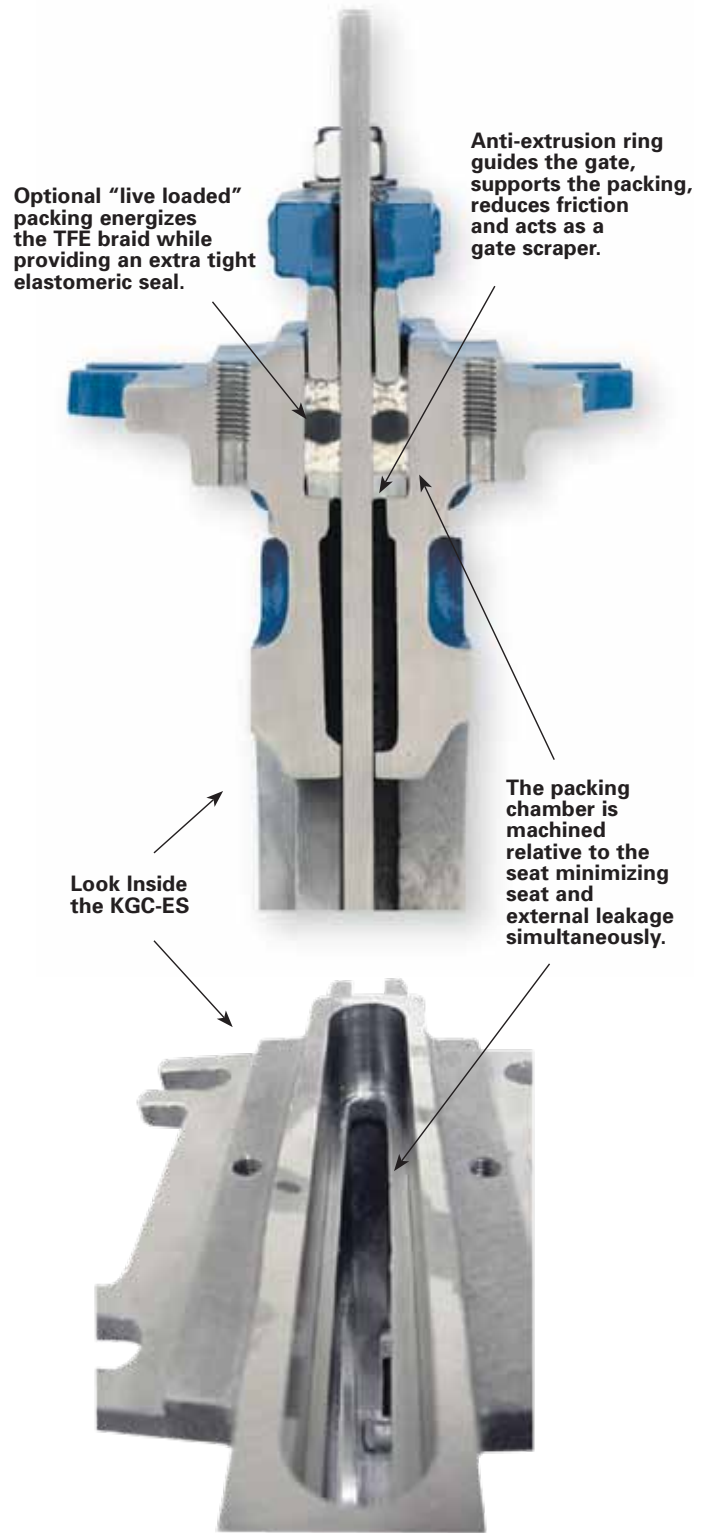
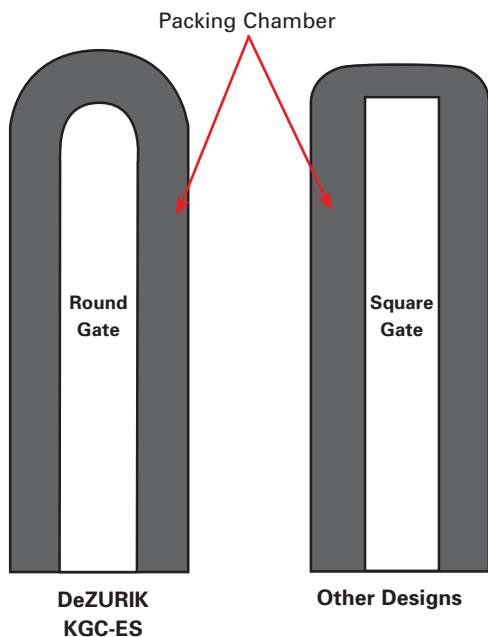

Test Data Proves - the "premium packing system" requires fewer packing adjustments and provides extended service life.

Putting "The Premium Packing System" To Work

The KGC-ES packing system includes a number of features that:

- Extend service life
- Reduce external leakage
- Minimize friction and actuator thrust required
- Require fewer packing adjustments
- Ensure alignment of the gate
- Allow field replacement of packing

High Performance Packing Material Options

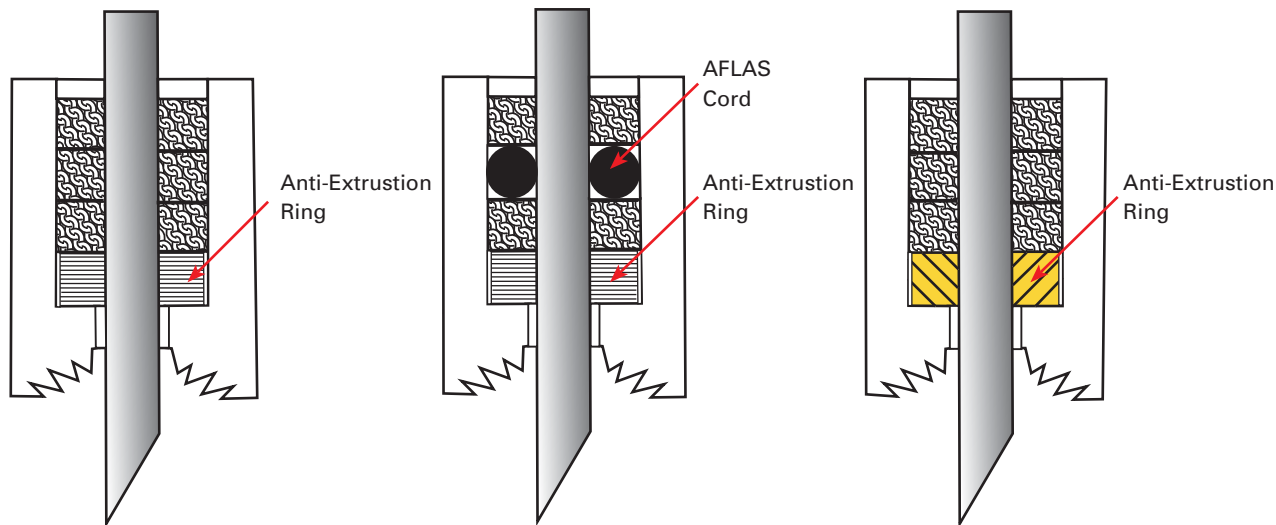

SMP

PTFE Braided Packing with Anti-Extrusion Ring to 500°F (260°C)
(pH Range: 0-14)

TDP

Dry Service, Dry PTFE Braided Packing with Solid PTFE Cord and Anti-Extrusion Ring to 500°F (260°C)
(pH Range: 0-14)

FGP

Food Grade Service with Anti-Extrusion Ring to 450°F (232°C)
(pH Range: 3-11)

ASP

Adjusting PTFE Braided Packing with AFLAS Fluoroelastomer Cord and Anti-Extrusion Ring to 400°F (205°C)
(pH Range: 0-14)

HTP

High Temperature Braided Packing with Carbon Fabric Reinforced Graphite Anti-Extrusion Ring to 650°F (343°C)
(pH Range: 1-12)

HMP

High Temperature Braided Packing with Metal Scraper Anti-Extrusion Ring to 1000°F (540°C)
(pH Range: 3-10)

Application Factors That Affect Your Packing Selection For Optimal Sealing

- Compatibility with process media
 - Wet or dry application
 - Food grade or non food grade
 - Life cycle stroke frequency
 - Temperature
 - pH Acid-Base level
 - Scaling or crystallization on gate
- Sealing
 - Energized AFLAS Fluoroelastomer Cord in ASP Packing will keep pressure on the packing material to maximize seal
 - Adjustable Packing Gland will renew and compress the packing to seal the valve
- Scraping
 - Anti-Extrusion Ring functions as a gate scraper, preventing process media from entering packing chamber.
- Supporting
 - Anti-Extrusion Ring supports packing, keeps packing from extruding between body and gate, and also maintains gate alignment to maximize sealing performance

Seat Options

Both metal and resilient seated valves are offered in a 100%, round port design. The integral metal seated or the replaceable 17-4 PH Stainless Steel H900 Heat Treated version is available with shutoff capability exceeding current MSS-SP81 standards.

Resilient Seated Valves

Resilient seated valves are available for applications where drip-tight shutoff is required. Unlike valves which use an o-ring seal, DeZURIK KGC-ES Valves have a replaceable resilient seat designed especially for knife gate valve applications. The resilient seat material is molded on three sides of the stainless steel seat ring. When the valve is closed, the gate is pushed against the seat and held in place by the gate jams. When the valve is open, the gate moves away from the seat, allowing clearance, which prevents seat damage and reduces operating force.

A variety of seat materials are available.

Options include:

CR - Chloroprene

NBR - Acrylonitrile-Butadiene

EPDM - Terpolymer of Ethylene, Propylene and a Diene

FKM - Fluoro Rubber

CRW - Chloroprene, off white

PTFE - Polytetrafluoroethylene, white

Reinforced PTFE - Polytetrafluoroethylene

Low Rim-Pull Force

A strong investment cast clip complements KGC-ES's robust construction. The single lead threads on the manual stem result in a lower required handwheel rim-pull force.



The stem has single lead threads to maximize mechanical advantage

Strong Investment Cast Connection



V-Orifice Design for Reliable Throttling and Modulation Control

An integral metal-seated V-port design is also available for reliable throttling control of thick slurries including paper stock. The constant V-orifice is maintained from open valve position to closed to prevent bridging or plugging and to ensure maximum control accuracy. Other orifice shapes available upon request.



Lockout Option

KGC-ES provides the latest in lockout design technology to protect both people and the environment. Unique designs for manual and automated models are available. The lockout collar for the automated models allows fine adjustment to ensure tight shutoff and maximum opening position. Lockouts are rated to withstand the maximum output of the actuators.

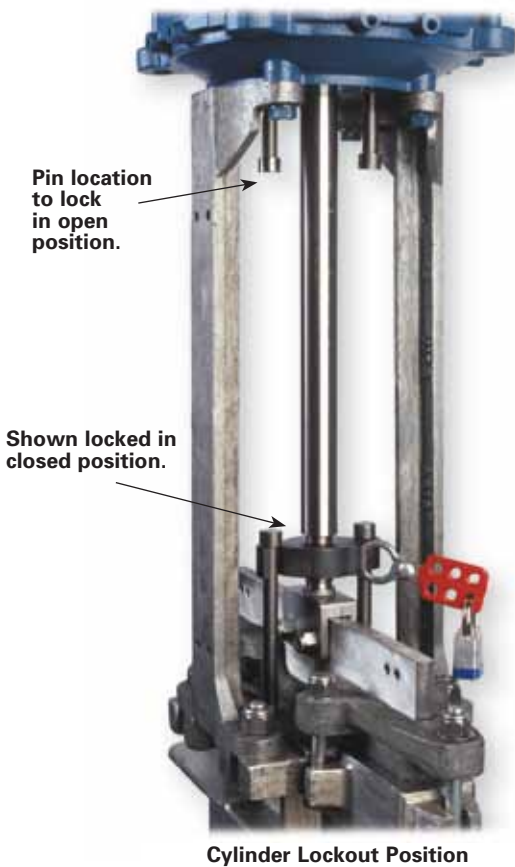

Actuators

- Handwheels
- Chainwheels
- Levers
- Bevel Gears
- Pneumatic Cylinders
- Hydraulic Cylinders
- Electric Motors

Accessories

A variety of accessories are offered as standard, including handwheel extensions, floorstands and a variety of cylinder actuator accessories for customizing the valve/actuator package to meet specific application requirements.

Options

DeZURIK Cast Knife Gate Valves may be ordered with the following options to meet your application requirements:

- Purge port connections
- Corrosion resistant cylinder actuator materials
- Lockouts
- Hardened/removable seats
- Hardened gates
- Bonnets

Sales and Service

For information about our worldwide locations, approvals, certifications and local representative:

Web Site: www.dezurik.com E-Mail: info@dezurik.com



250 Riverside Ave. N. Sartell, Minnesota 56377 • Phone: 320-259-2000 • Fax: 320-259-2227

DeZURIK, Inc. reserves the right to incorporate our latest design and material changes without notice or obligation. Design features, materials of construction and dimensional data, as described in this bulletin, are provided for your information only and should not be relied upon unless confirmed in writing by DeZURIK, Inc. Certified drawings are available upon request.