

DEZURIK MANUAL GEAR ACTUATOR

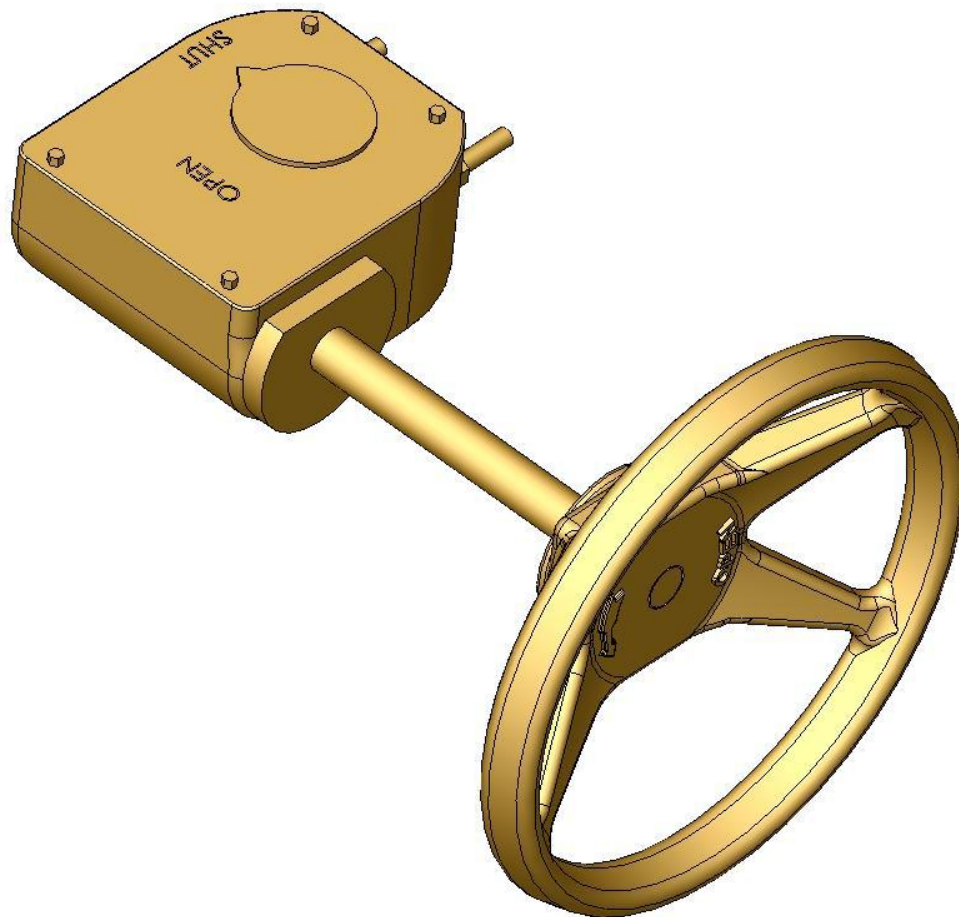

Instruction **D10408**
February 2026

Instructions

These instructions are for use by personnel who are responsible for the installation, operation and maintenance of DeZURIK valves, actuators or accessories.

Safety Messages

All safety messages in the instructions are identified by a general warning sign and the signal word CAUTION, WARNING or DANGER. These messages indicate procedures to avoid injury or death.

Safety label(s) on the product indicate hazards that can cause injury or death. If a safety label becomes difficult to see or read, or if a label has been removed, please contact DeZURIK for replacement label(s).

⚠WARNING

Personnel involved in the installation or maintenance of valves should be constantly alert to potential emission of pipeline material and take appropriate safety precautions. Always wear suitable protection when dealing with hazardous pipeline materials. Handle valves which have been removed from service with suitable protection for any potential pipeline material in the valve.

Inspection

Your DeZURIK product has been packaged to provide protection during shipment; however, items can be damaged in transport. Carefully inspect the unit for damage upon arrival and file a claim with the carrier if damage is apparent.

Parts

Replaceable wear parts are listed on the assembly drawing. These parts can be stocked to minimize downtime. Order parts from your local DeZURIK sales representative or directly from DeZURIK. When ordering parts please provide the following information:

If the valve has a data plate: please include the 7-digit part number with either 4-digit revision number (example: 9999999R000) or 8-digit serial number (example: S1900001) whichever is applicable. The data plate will be attached to the valve assembly. Also, include the part name, the assembly drawing number, the balloon number and the quantity stated on the assembly drawing.

If there isn't any data plate visible on the valve: please include valve model number, part name, and item number from the assembly drawing. You may contact your local DeZURIK Representative to help you identify your valve.

DeZURIK Service

DeZURIK service personnel are available to maintain and repair all DeZURIK products. DeZURIK also offers customized training programs and consultation services. For more information, contact your local DeZURIK sales representative or visit our website at DeZURIK.com.

Table of Contents

- Table of Contents 3
- Description 4
- Operation 4
- Lubrication..... 4
- Position Stops 5
 - Adjusting the Closed Position Stop..... 5
 - Adjusting the Open Position Stop 5
- Removing Actuator..... 5
- Adaptor Mounting Screws 6
 - MG-1012..... 6
- Mounting Actuator 7
 - Changing the Mounting Position 7
- Replacing a Handwheel with a Chainwheel 8
- Replacing a Chainwheel with a Handwheel 9
- Lockout..... 9
 - Operation..... 9
 - Adding a Lockout to Actuator..... 10
- Adjustable Memory Stop 11
 - MG-7 & MG-1012 11
 - MG-1216 & MG-16 12
- Replacing Pointer with Flag Indicator 13
- Troubleshooting 13

Description

The Manual Gear Actuator is a quarter-turn gear actuator. The actuator is available with a handwheel, chainwheel or 2" (50mm) square nut operator. Each actuator has adjustable open and closed position stops and may be mounted on the valve in four positions.

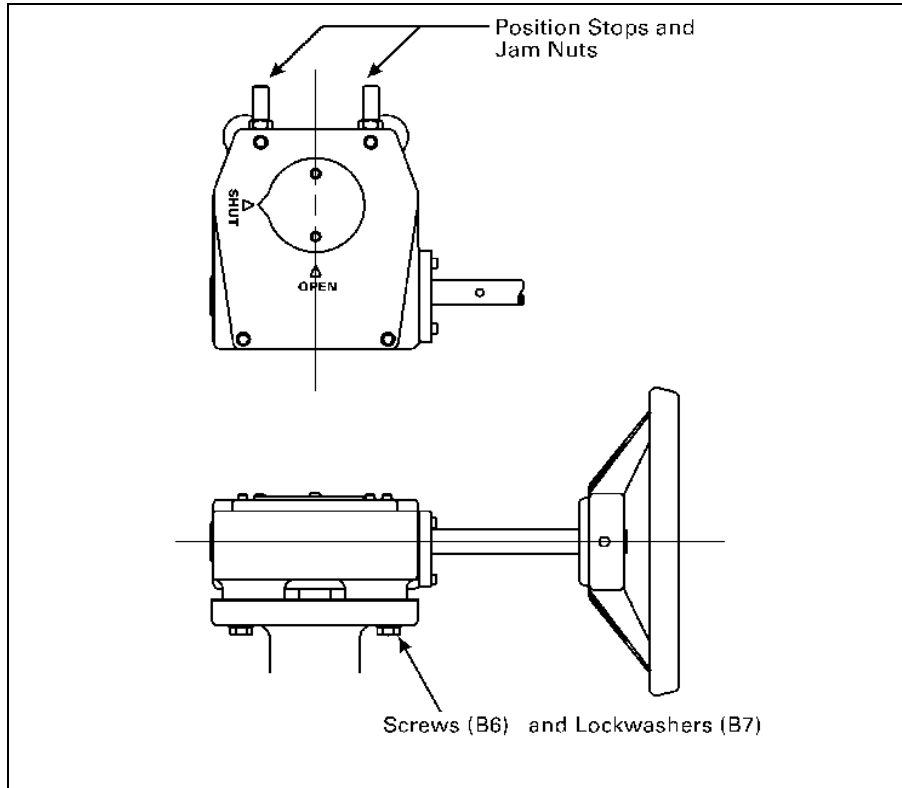

Figure 1— Component Identification

Operation

Clockwise rotation of the operator closes the valve; counterclockwise rotation opens the valve.

Lubrication

The actuator is lubricated at the factory and does not require further lubrication.

Position Stops

The open and closed position stops prevent the actuator from rotating beyond the open and closed positions of the valve. Each stop is adjustable. If the actuator is factory-mounted, the stops do not require adjustment. If the actuator is not factory mounted, or if the actuator has been removed, adjust the stops as described below. See Figure 1 for component identification.

Adjusting the Closed Position Stop

1. Loosen the jam nut on the closed position stop screw and loosen the stop screw about two turns.
2. Turn the handwheel so that the valve is in the closed position.
3. Turn the closed position stop screw clockwise until resistance is felt from the screw coming into contact with the gear inside of the actuator.
4. Hold the stop screw to prevent it from turning and tighten the jam nut to the torque shown in Table A.

Adjusting the Open Position Stop

1. Loosen the jam nut on the open position stop screw and loosen the stop screw about two turns.
2. Turn the handwheel so that the valve is in the open position.
3. Turn the open position stop screw clockwise until resistance is felt from the stop screw contacting the gear inside of the actuator.
4. Hold the stop screw to prevent it from turning and tighten the jam nut to the torque shown in Table A.

Table A: Jam Nut Torque

	Actuator			
	MG-7	MG-1012	MG-1216	MG-16
Torque, ft lbs	<u>6±2</u>	<u>21±5</u>	<u>21±5</u>	<u>45±5</u>
Jam Nut Nm	8±3	28±7	28±7	61±7

Removing Actuator

Refer to Figure 1 for component identification.



WARNING!

Flow in the pipeline with the actuator removed can slam the valve closed causing personal injury and damaging the flow system. Shut down the flow in the pipeline before removing the actuator from the valve.



WARNING!

This valve is a pressure vessel. Pressure must be completely released before disassembly. The bonnet will blow off if the bonnet bolts are removed with pressure in the valve.

DeZURIK

Manual Gear Actuator

1. Close the valve.
2. Remove the four mounting screws (B6) and lockwashers (B7).
3. Remove the actuator from the valve.

Adaptor Mounting Screws

The MG-1012 and MG-1216 Manual Gear Actuators have two sets of mounting holes.

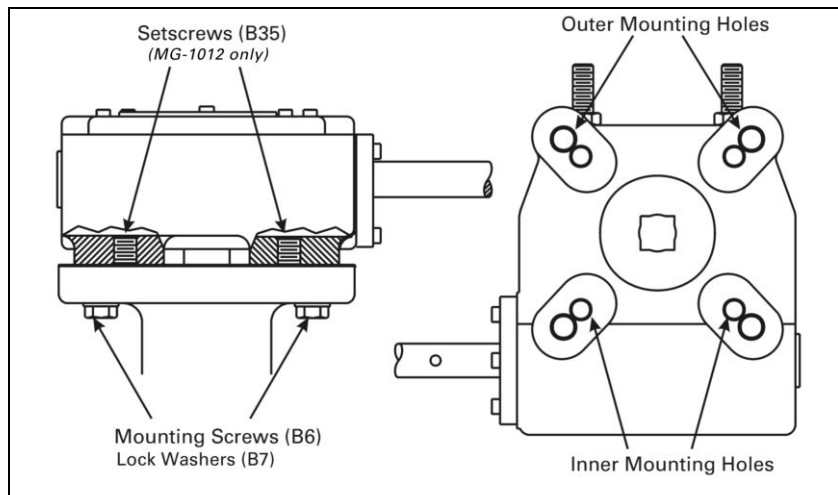

Figure 2 — Mounting Screw Locations

MG-1012

When using the outer mounting holes on the MG-1012 actuator, you must first remove the setscrews from the two mounting holes that are inline with the input shaft. When using the outer mounting holes, plug all interior holes with setscrews.

Note: Tighten the setscrews only until they are flush with the edge of the body. Make sure the setscrews are not protruding into the gears.

Table B: Mounting Bolt Torque ft. lb./Nm

Mounting Bolts	Actuator			
	MG-1012		MG-1216	
Torque, ft lbs Carbon Steel	<u>47±6</u>	<u>83±10</u>	<u>83±10</u>	<u>435±60</u>
Nm	64±8	113±14	113±14	592±81
Torque, ft lbs Stainless Steel	<u>33±4</u>	<u>58±8</u>	<u>58±8</u>	<u>300±40</u>
Nm	45±5	79±11	79±11	407±54

Mounting Actuator

Refer to Figure 1 for component identification.

1. Place both the actuator and the valve in the closed position.
2. Select the desired actuator mounting position from the optional positions shown on the installation drawing. Place the gasket in position (see note below), engage the actuator with the valve shaft, and slide the actuator into position on the top of the valve.

Note: All chainwheel actuators use a 1/32" (0.8 mm) thick gasket (B28) between the actuator and the chainwheel support (B29). High-temperature valves use a 1/16" (1.6 mm) thick insulating gasket (P5) on both handwheel and chainwheel operators. The insulating gasket is used only when the gasket is included with the valve.

3. Mount the actuator and gasket (see note above) to the valve with the four mounting screws (B6) and lockwashers (B7). Tighten the screws as shown in Table C or Table B.

Table C: Mounting Bolt Torque ft. lb./Nm

Mounting Bolts	Actuator			
	MG-7	MG-1012	MG-1216	MG-16
Torque, ft lbs Carbon Steel Nm	<u>23±3</u> 31±4	See Table B	See Table B	<u>435±60</u> 592±81
Torque, ft lbs Stainless Steel Nm	<u>16±2</u> 22±3	See Table B	See Table B	<u>300±40</u> 407±54

4. Adjust the open and closed position stops as shown in the Adjustments section.

Changing the Mounting Position

No additional components are needed to change the mounting position of the Manual Gear Actuator.

Before changing the actuator mounting position, check to assure that dimensional clearance is available for the proposed actuator location. The actuator may be mounted in any one of two or four positions as indicated on the installation drawing for the valve. To change the position, follow the steps in the "REMOVING ACTUATOR" and "MOUNTING ACTUATOR" sections.

Replacing a Handwheel with a Chainwheel

On sizes MG-7 through MG-16, the handwheel can be replaced with a chainwheel. Refer to Figure 1 for component identification.

1. Remove the actuator from the valve as described in the "REMOVING ACTUATOR" section.
2. Support the actuator shaft on a solid surface, drive out the handwheel pin (B31), and remove the handwheel (B10).

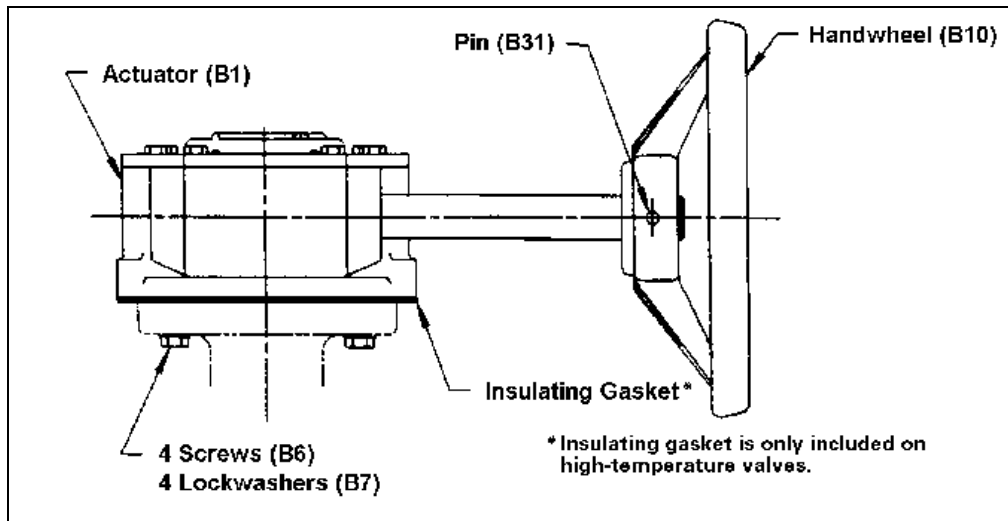

Figure 3—Handwheel

3. Place the shaft extension (B23) on the actuator shaft, and align the pin holes. Support the shaft extension on a solid surface, and drive the pin (B31) into position.

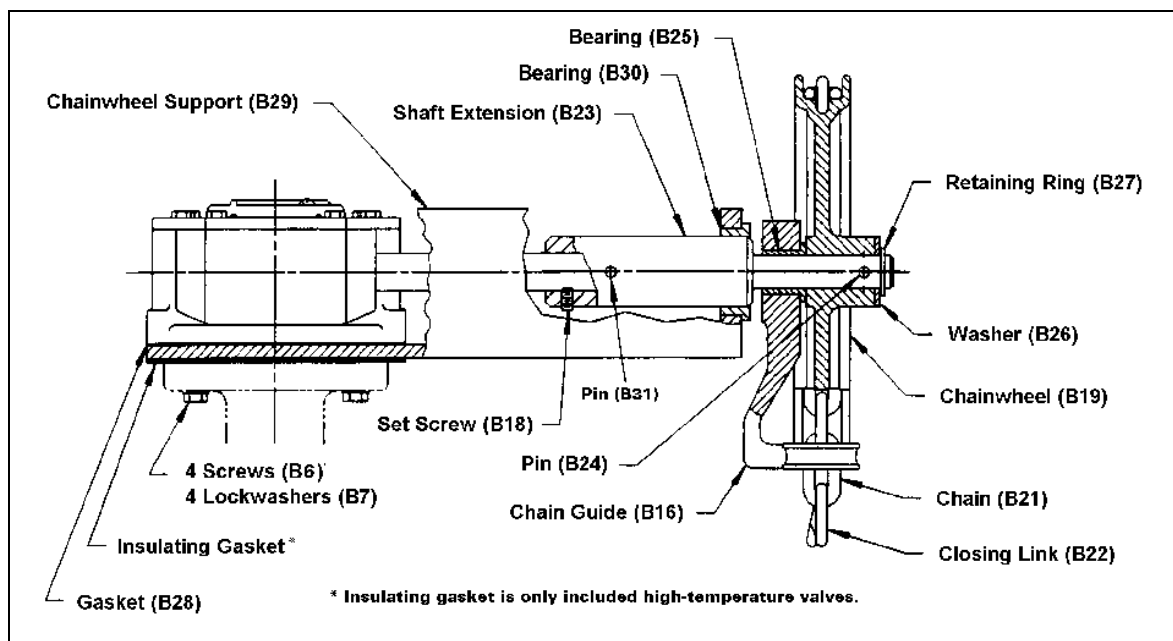

Figure 4—Chainwheel Assembly

4. Turn the set screw (B18) into the threaded hole in the shaft extension, and tighten the set screw to 7 ± 1 foot pounds (9 ± 1 Nm).

Replacing a Handwheel with a Chainwheel *(Continued)*

5. Place the gasket (B28) on the chainwheel support (B29) and align the holes in the gasket with the mounting holes.
6. Insert the shaft extension (B23) through the bearing (B30) in the chainwheel support (B29).
7. Place the chain guide (B16) and the chainwheel (B19) onto the shaft extension and align the pin holes in the shaft and the chainwheel.
8. Place the hub of the chainwheel on a solid surface and drive the pin (B24) into position.
9. Place the washer (B26) on the end of the shaft extension and then place the retaining ring (B27) in the groove on the end of the shaft extension.

Replacing a Chainwheel with a Handwheel

1. Remove the actuator from the valve as described in the “*REMOVING ACTUATOR*” section.
2. Loosen the set screw (B18) and drive out the pin (B31). Remove the support (B29) and the shaft extension (B23)—including the chain guide (B16) and the chainwheel (B19)—from the actuator.
3. Place the handwheel (B10) on the actuator shaft. Align the pin holes, support the actuator shaft on a solid surface, and drive the pin (B31) into position.
4. Replace the actuator on the valve as described in the “*MOUNTING ACTUATOR*” section.

Lockout

Operation

The handwheel actuator is available with an optional lockout that allows the handwheel to be locked with a padlock at any 1/8-turn increment. Lockouts may be ordered with a valve or ordered separately as a kit. A padlock is not included with the lockout accessory.

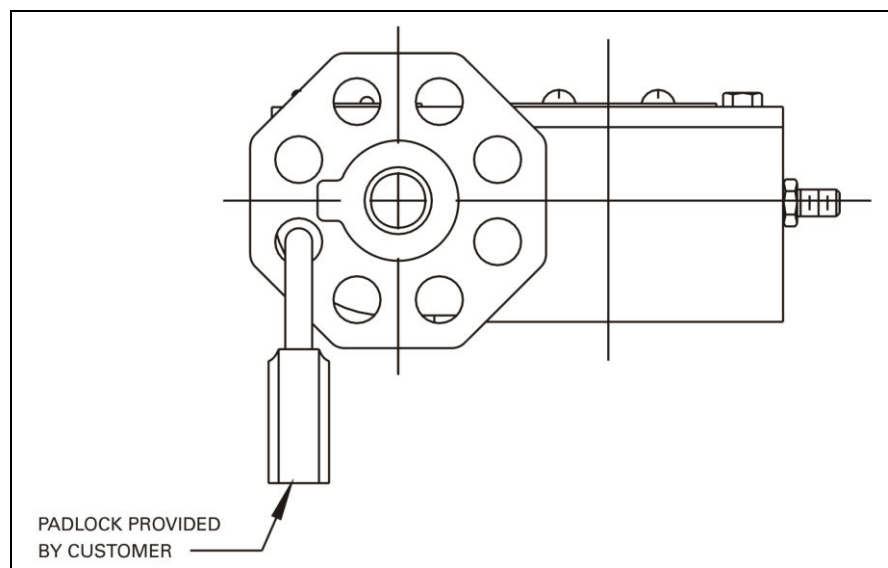

Figure 5—Lockout

Adding a Lockout to Actuator

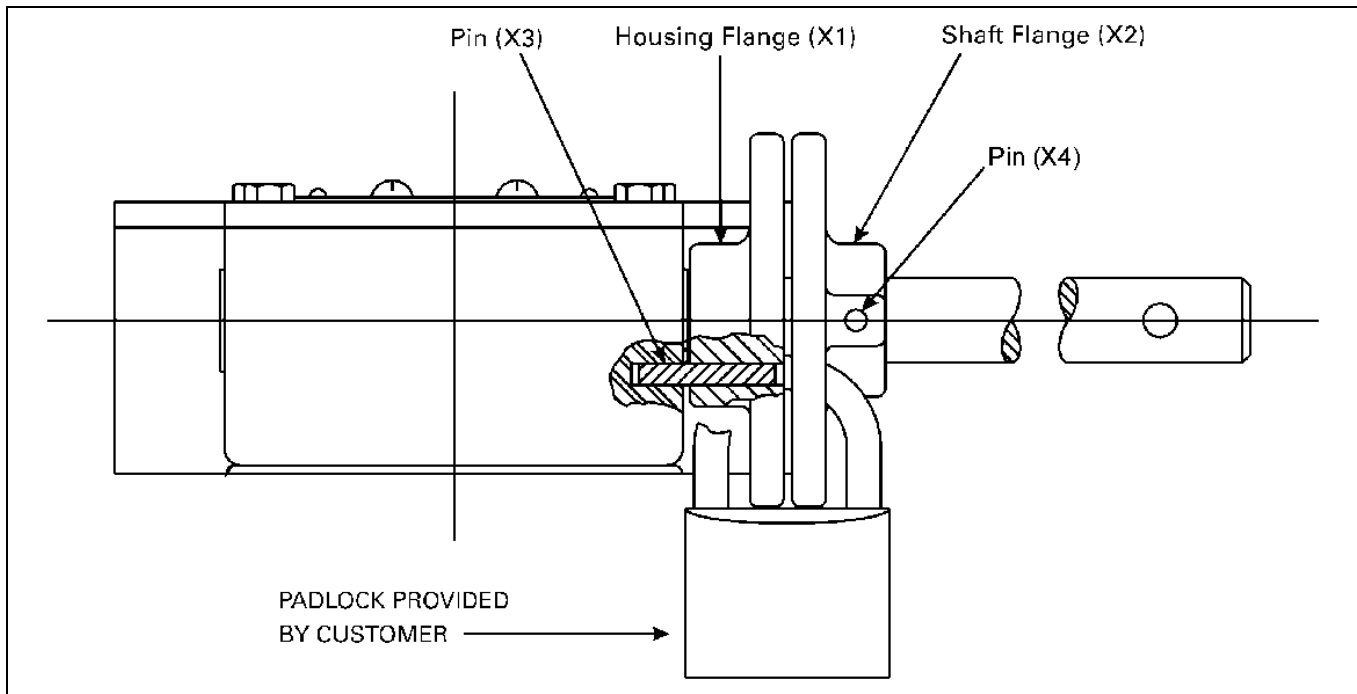

Figure 6—Lockout Parts

1. Remove the handwheel pin (B31) and remove the handwheel (B10) from the handwheel shaft.
2. Note the drilled hole in the side of the actuator next to the shaft. Insert the pin (X3) into the hole so that the pin is bottomed out in the hole.
3. With the hub side of the housing flange (X1) facing the actuator, slide the flange onto the shaft so that the hole in the flange is aligned with the pin (X3) in the actuator. Carefully drive the flange onto the pin until the flange hub is against the side of the actuator.
4. With the flat side of the shaft flange (X2) facing the actuator, slide the flange onto the shaft. Align the hole in the flange hub (X2) with the hole in the actuator shaft. Drive the shaft pin (X4) through the hole in the flange hub and into the hole in the shaft so that the pin is approximately flush with the flange hub.
5. Place the handwheel (B10) in the original position on the handwheel shaft and secure the handwheel with the pin (B31).

Adjustable Memory Stop

MG-7 & MG-1012

The Manual Gear Actuator (MG-7 & MG-1012) has an optional adjustable memory stop. The memory stop adjusts by rotating it around the pins. One side of the stop adjusts to 0, 30 and 60°; the other side adjusts to 15, 45, 75 and 90°.

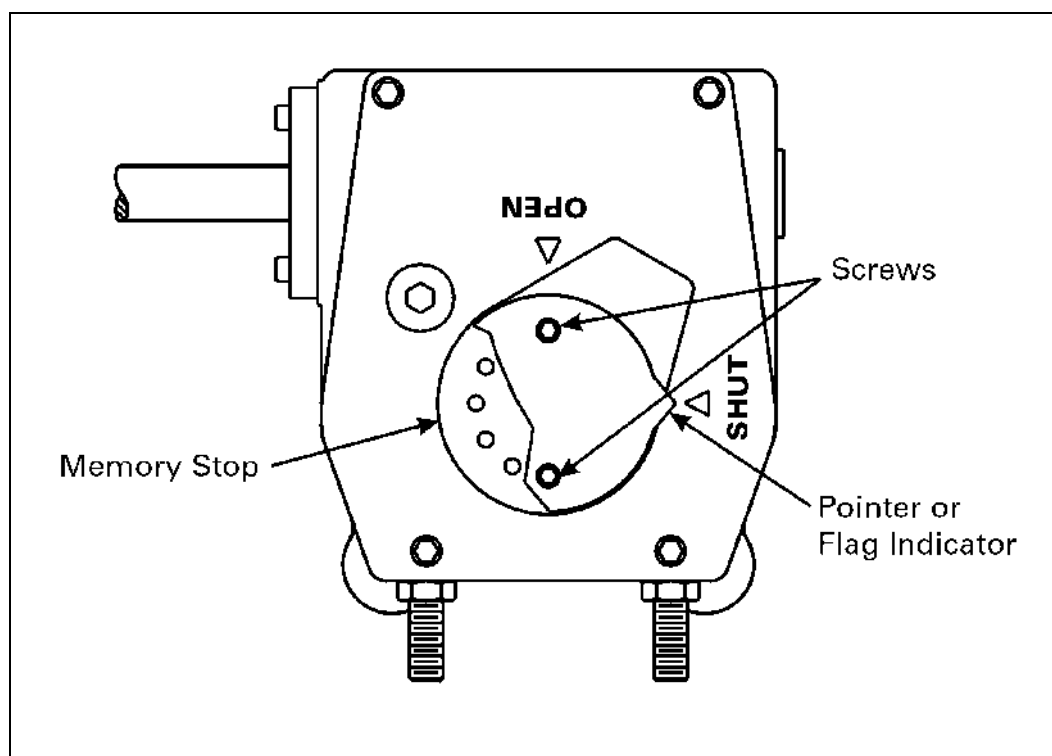

Figure 7—Memory Stop (MG-7 and MG1012)

To adjust the memory stop:

1. Remove the two screws, the pointer or flag indicator and the memory stop.
2. Position the actuator where you want it to stop.
3. Place the memory stop in position on the pins located on the gear.
Note: If needed, flip the stop over to adjust to the correct position.
4. Replace the pointer or flag indicator and tighten the screws to secure the stop. Ensure the pointer or flag indicator is aligned with the valve position.

Adjustable Memory Stop (Continued)

MG-1216 & MG-16

The Manual Gear Actuator (MG-1216 & MG-16) has an optional field mountable adjustable memory stop. The memory stop adjusts by rotating the traveling stop screw (T2) around the actuator shaft. For every rotation of the actuator shaft, there are 6 positions for stop adjustment.

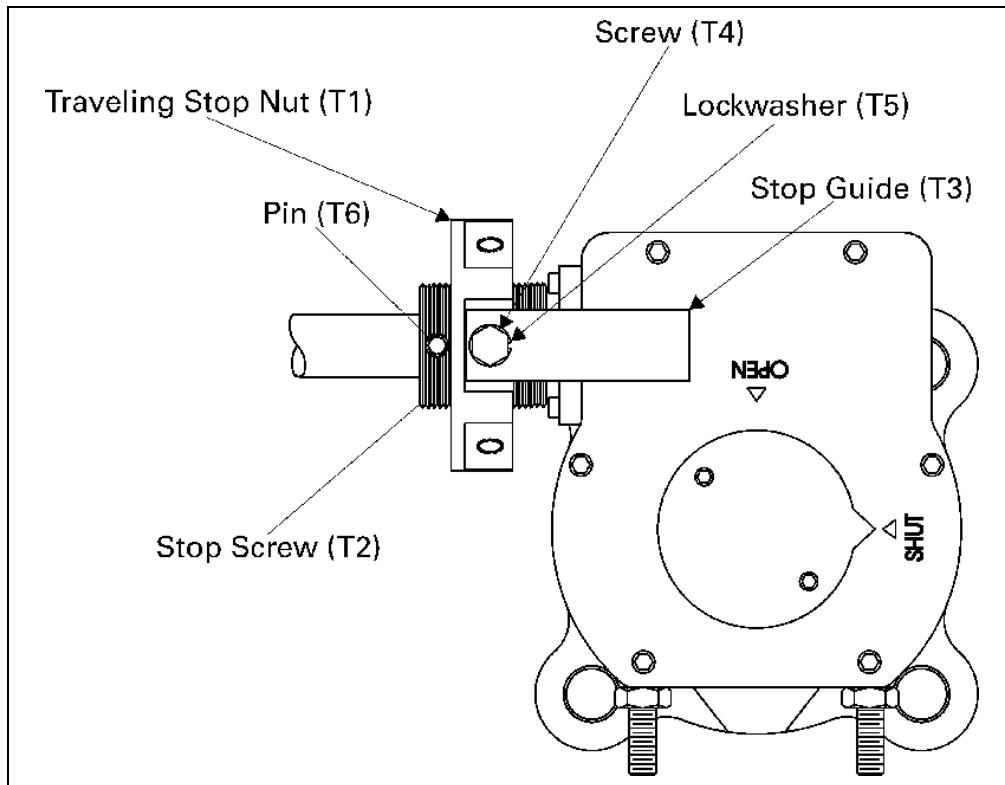

Figure 8—Memory Stop (MG-1216 & MG-16)

To adjust the memory stop:

1. Remove the handwheel, chainwheel or nut from the actuator shaft.
2. Slide the stop screw (T2) on to the actuator shaft.
3. Align the pin hole in the stop screw (T2) with the hole in the actuator shaft nearest the actuator housing.
4. Insert the pin (T6) into the pin hole in the stop screw (T2) and through the actuator shaft.
Note: Ensure the pin (T6) is recessed below the threads on both ends of the stop screw (T2).
5. Install the handwheel, chainwheel or nut on the actuator shaft. Position the actuator to the desired stop location.
6. Rotate the traveling stop nut (T1) until it makes contact with the actuator housing.
7. Attach the stop guide (T3) to the traveling stop nut (T1) so it is extended over the actuator housing with the screw (T4) and lockwasher (T5).

Replacing Pointer with Flag Indicator

1. Remove the screws holding the pointer and remove the pointer.

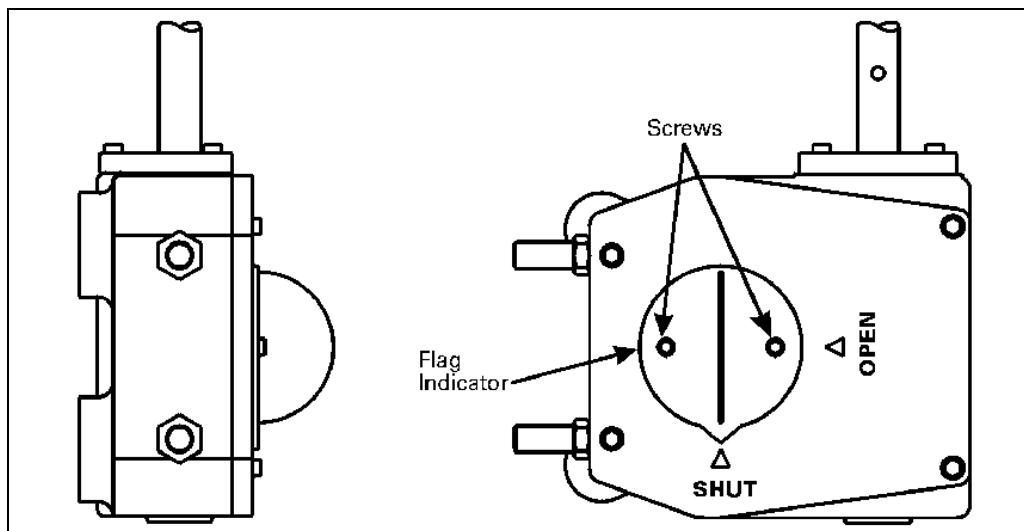

Figure 9—Flag Indicator

2. Using the same screws, attach the flag indicator to the actuator.

Note: Make sure the arrow is aligned with the valve position.

Troubleshooting

Condition	Possible Cause	Corrective Action
Actuator closes to wrong position.	Closed position stop is set incorrectly.	Adjust closed position stop.
Actuator opens to wrong position.	Open position stop is set incorrectly.	Adjust open position stop.
Actuator will not fully operate valve.	Internal pipeline obstruction is preventing closure.	Remove obstruction.
Actuator will not operate or will move only in one direction. *	Setscrews are interfering with gear operation.	Make sure the setscrews are flush with body.

* Models MG-1012 and MG-1216

Limited Warranty

DeZURIK, Inc. ("Seller") manufactured products, auxiliaries and parts thereof that we manufacture for a period of twenty-four (24) months from date of shipment from Seller's factory, are warranted to the original purchaser only against defective workmanship and material, but only if properly stored, installed, operated, and serviced in accordance with Seller's recommendations and instructions.

For items proven to be defective within the warranty period, your exclusive remedy under this limited warranty is repair or replacement of the defective item, at Seller's option, FCA Incoterms 2020 Seller's facility with removal, transportation, and installation at your cost.

Products or parts manufactured by others but furnished by Seller are not covered by this limited warranty. Seller may provide repair or replacement for other's products or parts only to the extent provided in and honored by the original manufacturer's warranty to Seller, in each case subject to the limitations contained in the original manufacturer's warranty.

No claim for transportation, labor, or special or consequential damages or any other loss, cost or damage is being provided in this limited warranty. You shall be solely responsible for determining suitability for use and in no event shall Seller be liable in this respect.

This limited warranty does not warrant that any Seller product or part is resistant to corrosion, erosion, abrasion or other sources of failure, nor does Seller warrant a minimum length of service.

Your failure to give written notice to us of any alleged defect under this warranty within twenty (20) days of its discovery, or attempts by someone other than Seller or its authorized representatives to remedy the alleged defects therein, or failure to return product or parts for repair or replacement as herein provided, or failure to store, install, or operate said products and parts according to the recommendations and instructions furnished by Seller shall be a waiver by you of all rights under this limited warranty.

This limited warranty is voided by any misuse, modification, abuse or alteration of Seller's product or part, accident, fire, flood or other Act of God, or your failure to pay entire contract price when due.

The foregoing limited warranty shall be null and void if, after shipment from our factory, the item is modified in any way or a component of another manufacturer, such as but not limited to; an actuator is attached to the item by anyone other than a Seller factory authorized service personnel.

All orders accepted shall be deemed accepted subject to this limited warranty, which shall be exclusive of any other or previous warranty, and this shall be the only effective guarantee or warranty binding on Seller, despite anything to the contrary contained in the purchase order or represented by any agent or employee of Seller in writing or otherwise, notwithstanding, including but not limited to implied warranties.

THE FOREGOING REPAIR AND REPLACEMENT LIMITED WARRANTY IS IN LIEU OF ALL OTHER WARRANTIES, OBLIGATIONS AND LIABILITIES, INCLUDING, BUT NOT LIMITED TO, ALL WARRANTIES OF FITNESS FOR A PARTICULAR PURPOSE OR OF MERCHANTABILITY OR OTHERWISE, EXPRESSED OR IMPLIED IN FACT OR BY LAW, AND STATE SELLER'S ENTIRE AND EXCLUSIVE LIABILITY AND YOUR EXCLUSIVE REMEDY FOR ANY CLAIM IN CONNECTION WITH THE SALE AND FURNISHING OF SERVICES, GOODS OR PARTS, THEIR DESIGN, SUITABILITY FOR USE, INSTALLATION OR OPERATIONS. NEITHER ANY PERFORMANCE OR OTHER CONDUCT, NOR ANY ORAL OR WRITTEN INFORMATION, STATEMENT, OR ADVICE PREPARED BY SELLER OR ANY OF OUR EMPLOYEES OR AGENTS WILL CREATE A WARRANTY, OR IN ANY WAY INCREASE THE SCOPE OR DURATION OF THE LIMITED WARRANTY.

Disclaimer

Metric fasteners should not be used with ASME Class 150/300 bolt holes and flange bolt patterns. If you use metric fasteners with ASME Class 150/300 bolt holes and flange bolt patterns, it may lead to product failure, injury, and loss of life. DeZURIK Inc. disclaims all liability associated with the use of metric fasteners with ASME Class 150/300 bolt holes and flange patterns, including but not limited to personal injury, loss of life, loss of product, production time, equipment, property damage, lost profits, consequential damages of any kind and environment damage and/or cleanup. Use of metric fasteners with ASME Class 150/300 bolt holes and flange bolt patterns is a misuse that voids all warranties and contractual assurances. If you use metric fasteners with ASME Class 150/300 bolt holes and flange bolt patterns, you do so at your sole risk and any liability associated with such use shall not be the responsibility of DeZURIK, Inc. In addition to the foregoing, DeZURIK's Manufacturer's Conditions apply.

Limitation of Liability

IN NO EVENT SHALL SELLER BE LIABLE FOR ANY DIRECT, INDIRECT, SPECIAL, PUNITIVE, EXEMPLARY, OR CONSEQUENTIAL DAMAGES (INCLUDING, BUT NOT LIMITED TO; DAMAGE TO OR LOSS OF OTHER PROPERTY OR EQUIPMENT, BUSINESS INTERRUPTION, COST OF SUBSTITUTE PRODUCTS, LOSS OF TIME, LOSS OF PROFITS OR REVENUE, COST OF CAPTIAL, LOSS OF USE, OR DIMINUTION IN VALUE) WHATSOEVER, AND SELLER'S LIABILITY, UNDER NO CIRCUMSTANCES, WILL EXCEED THE CONTRACT PRICE FOR THE GOODS AND/OR SERVICES FOR WHICH LIABILITY IS CLAIMED. ANY ACTION FOR BREACH OF CONTRACT BY YOU, OTHER THAN RIGHTS RESPECTING OUR LIMITED WARRANTY DESCRIBED ABOVE, MUST BE COMMENCED WITHIN 12 MONTHS AFTER THE DATE OF SALE.

Sales and Service

For information about our worldwide locations, approvals, certifications and local representative:

Web site: www.dezurik.com E-Mail: info@dezurik.com



250 Riverside Ave. N., Sartell, MN 56377 • Phone: 320-259-2000 • Fax: 320-259-2227

DeZURIK, Inc. reserves the right to incorporate our latest design and material changes without notice or obligation.

Design features, materials of construction and dimensional data, as described in this manual, are provided for your information only and should not be relied upon unless confirmed in writing by DeZURIK, Inc. Certified drawings are available upon request.