

DeZURIK RCV ROTARY CONTROL VALVES



RCV Rotary Control Valves

Design and Construction

The DeZURIK RCV Rotary Control Valve has been specially engineered for extremely precise throttling control in severe-service applications in the pulp and paper, chemical, power, petroleum and refining industries. The RCV is ideally suited for tough applications where high-pressure media contain entrained water vapor or suspended abrasive particles including:

- Scaling liquor service
- Dirty steam service
- Kaolin slurry
- Lime mud
- TiO₂ slurry
- Fly ash slurry
- Coking
- Hard-to-handle liquids, gases and slurries

The DeZURIK RCV Rotary Control Valve combines the control accuracy of a globe valve with the strength of a severe-service ball valve. Traditionally, a ball valve that could withstand erosion, corrosion and scaling media couldn't provide precise throttling accuracy. And a globe valve could provide great control, but could only handle clean media. But with the RCV, accurate control doesn't have to be sacrificed to get a valve that can withstand tough applications.

Hard-faced trim components and unique design features provide erosion resistance up to eight times better than trim produced from Alloy #6. The RCV is designed for high-capacity, bi-directional flow capability and includes four trim options for flexibility.

In the event maintenance is needed, DeZURIK's unique design facilitates fast, easy breakdown and assembly of valve components with no special tools required. The result is reduced maintenance time and the lowest overall cost of ownership.

Available in sizes 1–12" (25–300mm), the DeZURIK RCV Rotary Control Valve is available in ASME Class 150 and Class 300 ratings. Body material options include 316 and 317 stainless steel, carbon steel, Hastelloy C or Titanium. Flanged or flangeless designs meet ASME or ISA face-to-face dimensions.

Metal-seated valves provide FCI 70-2/ANSI Class IV shutoff and temperature capabilities up to 1000°F (540°C).



90 Degree Control

While other rotary control valves offer only 60° range of motion (180 positions), DeZURIK RCV Rotary Control Valves operate over the full 90°, providing up to 200 discrete positions. The additional range of motion allows the RCV to provide finer, more precise control. RCV Valves have a modified equal percentage flow curve.

Throttling Accuracy

DeZURIK RCV Rotary Control Valves provide unparalleled control of the process, including fast, accurate response to signal changes. Accuracy of up to 0.5% means a resolution of up to 200 discrete positions of operation. The RCV exceeds both industry valve dynamic performance standards and the accuracy levels of most competitive valves. The rigid splined and locked plug-to-shaft connection effectively eliminates mechanical backlash and hysteresis. DeZURIK RCV Rotary Control Valve is often an economic alternative to globe control valves in 3–12" (80–300mm) sizes in clean liquid or gas service because it is capable of industry-leading accuracy and speed of response.

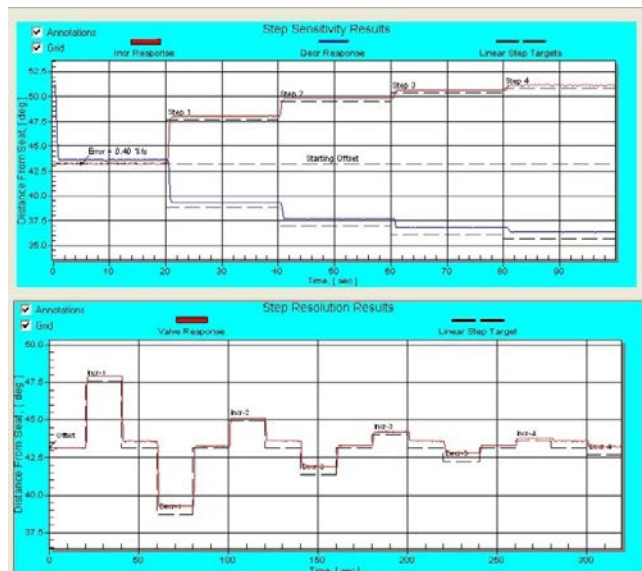

High Flow Capacity Saves Money

DeZURIK RCV Rotary Control Valves have the highest flow capacity ratings in the industry. On new plants or retrofits, RCV can save plants thousands of dollars because of its high flow capacity. The charts below compare the maximum flow capacity (Cv) of the RCV with two other leading brands.

Cv Values

1–2.5" (25–65mm), RCV vs Brands A and B

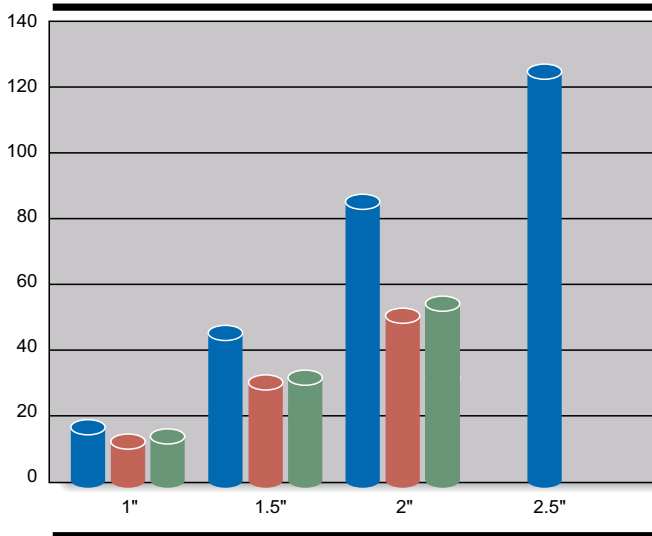

Size for size, the RCV provides far more Cv per dollar—an average of 30% more—allowing the use of smaller, lighter and more cost-effective valves and actuators. The high flow capacity means that one size, or sometimes two sizes, smaller valves can be used, saving precious capital expenditure money. Smaller valve and actuator sizes also mean less costly maintenance and repair over the life of the valve.

3–12" (80–300mm), RCV vs Brands A and B

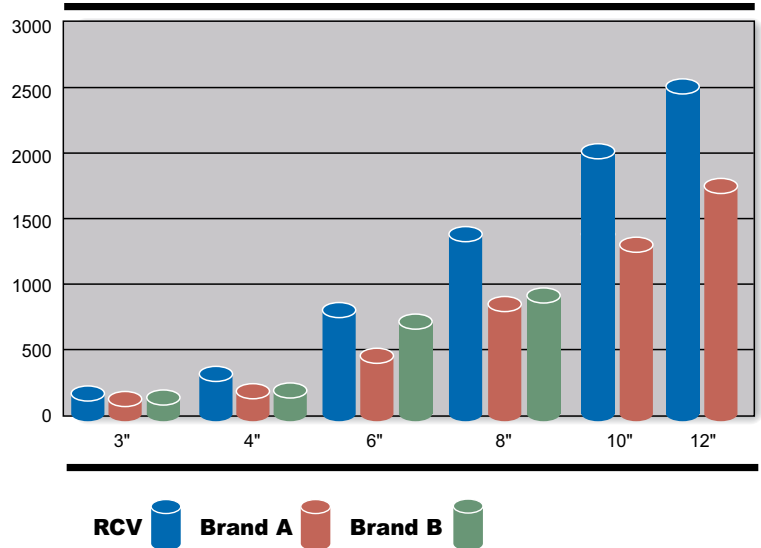

Capacity Increases Easily Accomplished

The four trim sizes of the DeZURIK RCV Rotary Control Valve allow a valve with reduced trim to be installed that provides optimal control for today's conditions. In the future, when capacity increases are needed, the valve seat can be changed to allow much more capacity. With a simple seat change, rather than a valve replacement, the plant's capacity can be increased without compromising control or incurring significant expense.



Four Flow Capacity Ranges

DeZURIK RCV Rotary Control Valves are available with four flow capacity ranges to provide the maximum in application flexibility. High, full, 0.5 and 0.2 reduced trim all provide precise flow control and can easily be interchanged in the field. High flow capacity means smaller valves can often satisfy the same flow requirement as larger competitive valves. Smaller valves use smaller, less costly actuators thereby saving initial costs.

Seat Options

Maximum flexibility is achieved with two seat material options: electroless nickel coated stainless steel and stainless steel with tungsten carbide overlay. Shutoff is ANSI/FCI 70-2, Class IV.

Bi-Directional Flow Capability

DeZURIK RCV Rotary Control Valves provide bi-directional flow capability that increases the valve's flexibility. On slurry and erosive applications, valve and trim life can be optimized by installing the valve in a flow-to-close direction.

Self-Aligning Plug and Seat

The self-aligning plug and seat on the DeZURIK RCV Rotary Control Valve reduces lengthy setup time during repair and reassembly. Valves can easily be returned to like-new performance without time-consuming special procedures. And, because of the orbital seat design, the plug and seat self-compensate for wear on either surface. This means that plugs and seats do not have to be machine-matched compared to many competitor's valves. Individual plugs and seats can be maintained in storerooms—again reducing inventory on hand and associated costs.

Common Valve Components

DeZURIK RCV Rotary Control Valve was designed to share a majority of valve components with DeZURIK's V-Port Ball Valve (VPB). The two valves use the same bodies, packing components, bearings, brackets and fasteners. Within RCV valve sizes there are common parts as well. Trim components between 150 and 300 pressure classes are the same. Many sizes share identical valve shafts, packing sets and packing glands. These common components help minimize expensive storeroom inventory of replacement parts.

Uninterrupted Gasket Surface

DeZURIK RCV Rotary Control Valves feature a full, uninterrupted raised-face gasket surface that provides maximum gasket integrity. The gasket surface provides full seal contact area with ASME B16.20 gaskets.



High-Alloy Valves Available

Titanium RCV valves are ideally suited for severely corrosive applications such as sodium chlorate, chlorine dioxide, terephthalic and hot acetic acid. RCV valves are also available in 316/317 stainless steel, carbon steel, Hastelloy C and Titanium.

Field-Proven Durability

DeZURIK RCV Rotary Control Valves have been proving their durability in highly erosive services with high-pressure drops for years. For example, the chart below lists actual case histories in which all valves exceeded customer expectations.

Application	Pressure Drop Across The Valve psi (kPa)	Temperature Degrees F (C)
Digester Gas-Off	180 (1240)	460° (240°)
Kaolin Slurry	70 (480)	320° (160°)
Fly Ash	35 (240)	500° (260°)
Titanium Dioxide	70 (480)	70° (20°)
Steam	45 (310)	281° (140°)

Rugged, Easy-to-Maintain Construction

The heavy-duty, cast body is a one-piece design for increased installed pipe integrity and minimal potential leak paths. Stainless steel or high-alloy construction, combined with drop-in seats and a splined plug-to-shaft connection make the DeZURIK RCV Rotary Control Valve easy to maintain.

Streamlined Maintenance

DeZURIK RCV Rotary Control Valves feature the simplest maintenance procedures of any rotary eccentric or globe-style control valve available. There are no threaded trim parts. The seat retainer and trim components drop in place ensuring precise alignment of plug and seat. Disassembly and reassembly are easily completed with no special wrenches or other special tools required. On highly erosive services where routine maintenance is expected, the RCV's drop-in trim, sealed bearings and self-aligning plug/seat reduce maintenance costs and minimize lost production. As standard, all DeZURIK RCV Rotary Control Valve fasteners are stainless steel for easy disassembly. An additional maintenance feature is a bottom access cover for valve disassembly and reassembly.

Erosion-Resistant Services Package

DeZURIK RCV Rotary Control Valve has been designed specifically for highly erosive services. The tungsten carbide coated trim components have a Rockwell C68 hardness and provide superior erosion resistance compared to typical valve trim facings. Combined with the sealed bearing option that prevents media from hindering continuous operation, the RCV provides long life on tough applications.

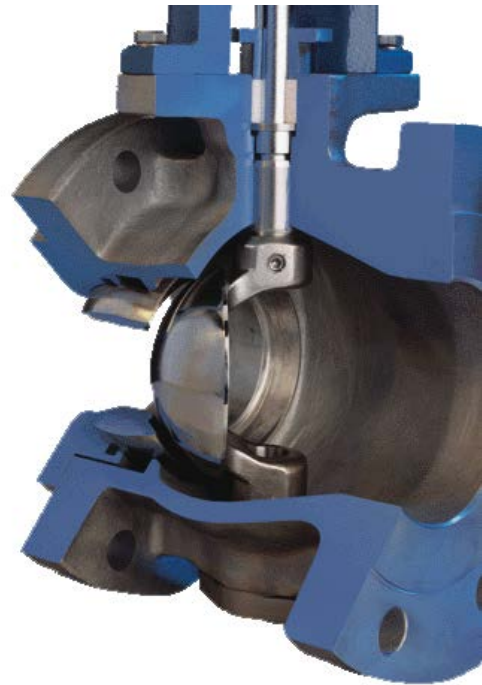

Sealed Bearings

The sealed-bearing option prevents media from entering the bearing areas, which can hinder valve operation. Perfluoro-elastomer seals are available for bearings that need exceptional protection from scaling, plating, abrasive or polymerizing media.



Corrosion-Resistant Bearings

The one-piece bearing provides a large area of radial support to the shaft. The shaft is fully supported, greatly reducing shaft fatigue and breakage. The metal bearing has a low coefficient of friction that minimizes operating torques and reduces actuator sizing requirements.



Steam Service Package

The DeZURIK RCV Rotary Control Valve is an excellent choice for economical steam control compared with more expensive globe-style valves. The RCV withstands pressures up to 740 psi (5100 kPa). The steam service package is designed for long-term, trouble-free valve performance and includes a carbon steel body, 2205 super duplex stainless steel shaft, 440C stainless steel bearings, a seat with a tungsten carbide overlay and a non-porous, hardened electroless nickel-coated plug (RC70).

Actuator Flexibility Options

DeZURIK RCV Rotary Control Valves are available with DeZURIK PowerRac® or Diaphragm Actuators. The actuator top mounting pads or adapter brackets of currently manufactured DeZURIK rotary control and isolation valves (RCV, VPB, BHP, BOS) are compatible with the ISO-5211/1 standard. This common actuator platform increases flexibility and helps reduce spare parts inventory.

Cylinder Actuators

PowerRac® Cylinder actuators are available as double-acting or spring return. They feature a high opening torque for on-off applications and also maintain a high operating torque throughout the full stroke for modulating service.

Diaphragm Actuators

Diaphragm actuators DR-40B & DR-85B are 316 stainless steel construction to provide corrosion resistance for a wide range of demanding industrial environments. They are designed for on-off or modulating service in either a Reverse (spring-to-close) or Direct (spring-to-open) mode. Fail action can be easily changed in the field by flipping the actuator over with no additional parts required. Larger size diaphragm actuators DR-145 & DR-250 are available to accommodate larger valve sizes and higher shutoff pressure differentials.



Close Coupling of Actuator to Valve

DeZURIK Diaphragm and PowerRac® actuators rigidly connect to the valve and the positioner on the actuator housing. This accurately feeds exact valve position directly to the positioner. In addition, the close coupling of the actuator to the valve makes the total package as compact as possible.



Accessories

A full line of accessories integrated to the actuator system is available to meet your individual mill/plant requirements.

Digital Positioners

Digital positioners improve reliability and performance through accurate calibration. Accurate calibration is achieved by the touch of a button, the positioner self-calibrates. They also offer diagnostic capabilities which monitor variables in the valves such as valve travel, valve friction, air consumption, and more to ensure operation is at peak performance. Digital positioners are available with HART, Foundation Fieldbus, or Profibus communication protocols. Digital positioners can also be used in a conventional 4-20 mA, analog control environment.



Manual Gear Actuators

Manual gear actuators with handwheel or chainwheel input are available in cast iron construction. They feature sintered bronze bearings on each end of the input shaft for durability and performance.

Materials of Construction

Flanged

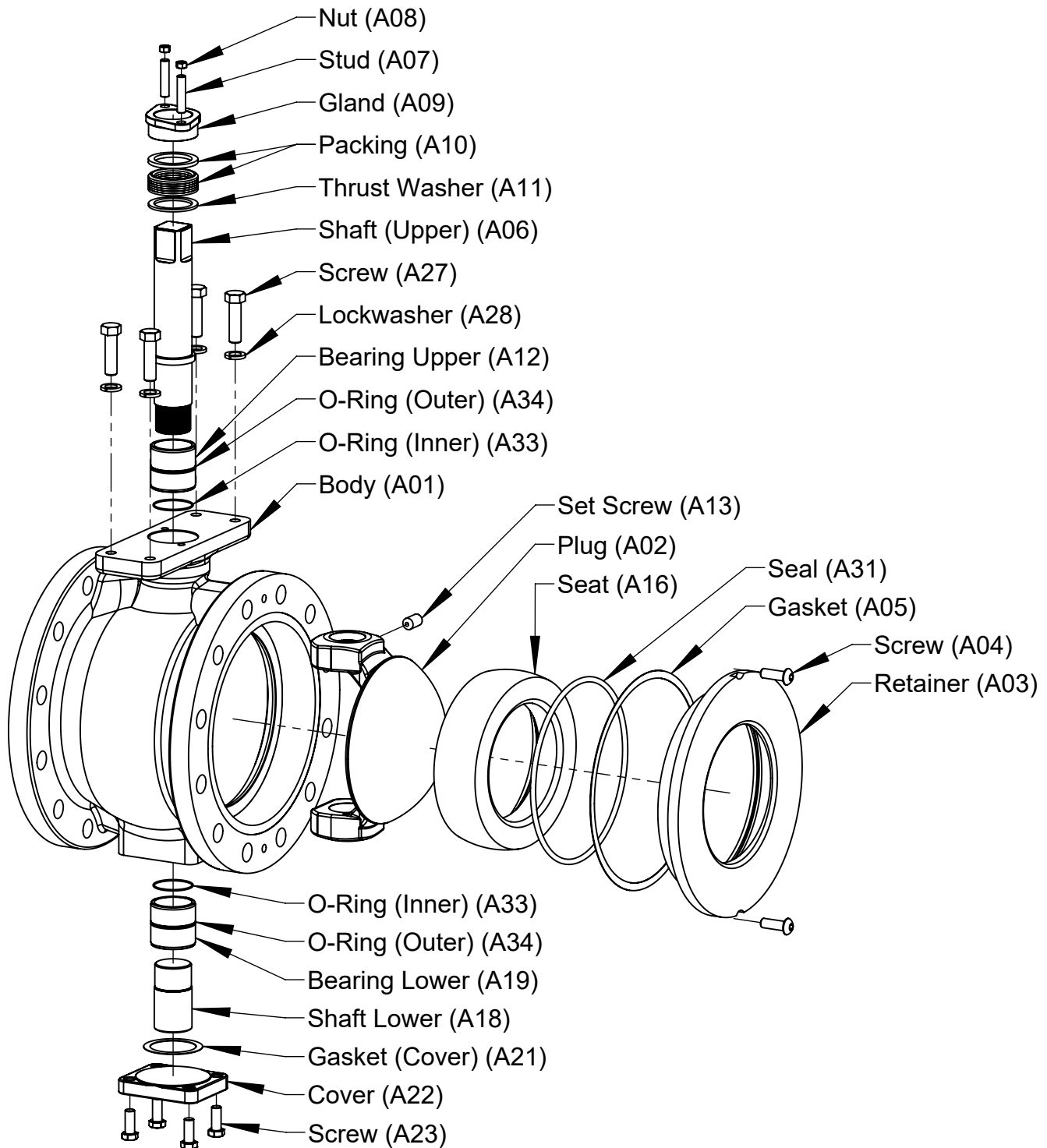

Materials of Construction

Flangeless

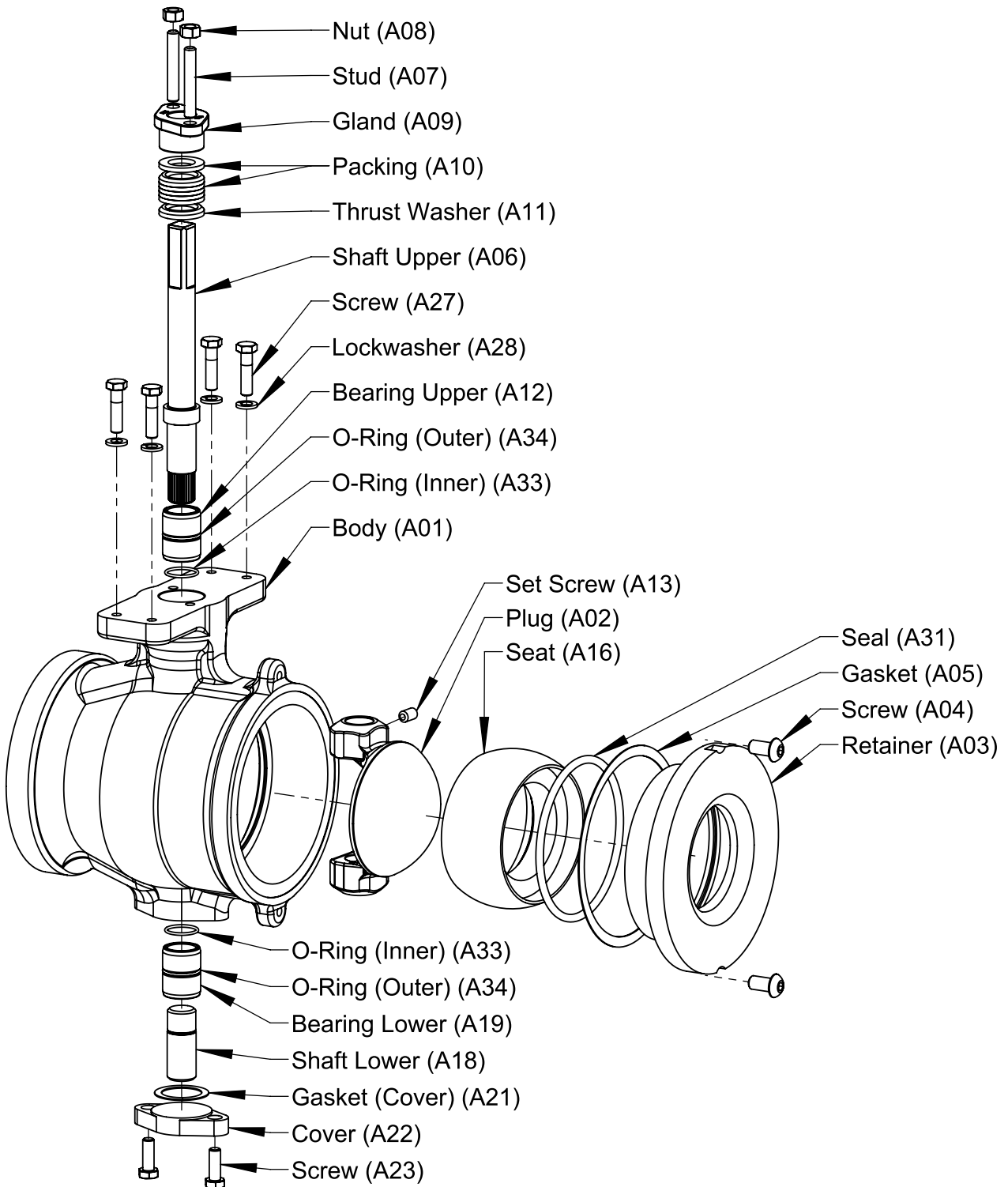

Materials of Construction

Item	Description	Material
A01	Body	316 Stainless Steel, ASTM A351, Grade CF8M
		317 Stainless Steel, ASTM A743, Grade CG8M
		Carbon Steel, ASTM A216, Grade WCB
		Hastelloy C, ASTM A494, Grade CW2N
		Titanium, ASTM B367, Grade 5
A02	Plug	317 Stainless Steel, ASTM A743, Grade CG8 with electroless nickel plating
		317 Stainless Steel, ASTM A743, Grade CG8M with tungsten carbide coating
		Hastelloy C, ASTM A494, Grade CW2N with electroless nickel plating
		Titanium, ASTM B367, Grade 5 with anodized coating, type II
A03	Retainer	Same as Body
A04	Screw	18-8 Stainless Steel
A05	Gasket	Industrial Grade Flexible Carbon Graphite
A06	Shaft Upper	17-4 pH Stainless Steel, ASTM A564
		2205 Stainless Steel, ASTM A276
		Titanium, ASTM B348, Grade 5, Ceramic Coated
A07	Stud	18-8 Stainless Steel
A08	Nut	18-8 Stainless Steel
A09	Gland	317 Stainless Steel, ASTM A743, Grade CG8M
		Hastelloy C, ASTM A494, Grade CW2N
		Titanium, ASTM B265, Grade 3
A10	Packing	Virgin PTFE
		Flexible Carbon Graphite with Inconel Core
A11	Thrust Washer	317 Stainless Steel, ASTM A276
		Hastelloy C, ASTM B574
		Titanium, ASTM B265, Grade 2
A12	Bearing Upper	440C Stainless Steel, ASTM A276
		Alloy 6, AMS 5387B, Cobalt-Chromium Alloy
		Hastelloy C, ASTM B574
		Titanium, ASTM B265, Grade 5
A13	Set Screw	316 Stainless Steel, ASTM A276
		Alloy 20, ASTM B473
		Titanium, Grade 2
A16	Metal Seat	317 Stainless Steel, ASTM A276 with Electroless Nickel Plating
		317 Stainless Steel, ASTM A276 with Tungsten Carbide Coating
		Hastelloy C, ASTM B574 with Electroless Nickel Plating
		Hastelloy C, ASTM B574
		Titanium, ASTM B367, Grade 5 with anodized coating, type II
A18	Shaft Lower	Same as Shaft Upper
A19	Bearing Lower	Same as Bearing Upper
A21	Gasket	Industrial Grade flexible carbon graphite
	O-Ring	Perfluoro-elastomer (titanium construction)
A22	Cover	Same as Body
A23	Screw	18-8 Stainless Steel
		Titanium, Grade 2 (Titanium Construction)
A27	Screw	18-8 Stainless Steel
A28	Lockwasher	18-8 Stainless Steel
A31	Seal	Fluoro Rubber Encapsulated in PFA
		Nickel-chromium alloy X750
A33	O-Ring (Inner)	Fluoro Rubber Encapsulated in PFA
A34	O-Ring (Outer)	Perfluoro-elastomer

Applicable Standards

RCV Rotary Control Valves are designed and/or tested to meet the following standards:	
ANSI/FCI 70-2	Control valve seat leakage
ASME B16.5	Pipe flanges and flanged fittings for Class 150 and 300
ASME B16.34	Pressure/temperature ratings for Class 150 and 300 valves
MSS-SP-25	Marking requirements
Bolting	ASME 150 & 300, PN 10, 16, 25 & 40, JIS 10, 16 & 20
ISA 75.04	Face-to-Face dimensions
ASME B16.10	Face-to-Face dimensions
IEC 534-3-2	Face-to-Face dimensions
ISO 5752 PN 10/16	Basic Series 3 Face-to-Face dimensions
EN 558-1 PN 10/16	Basic Series 3 Face-to-Face dimensions

Valve Selection

Flow Characteristic

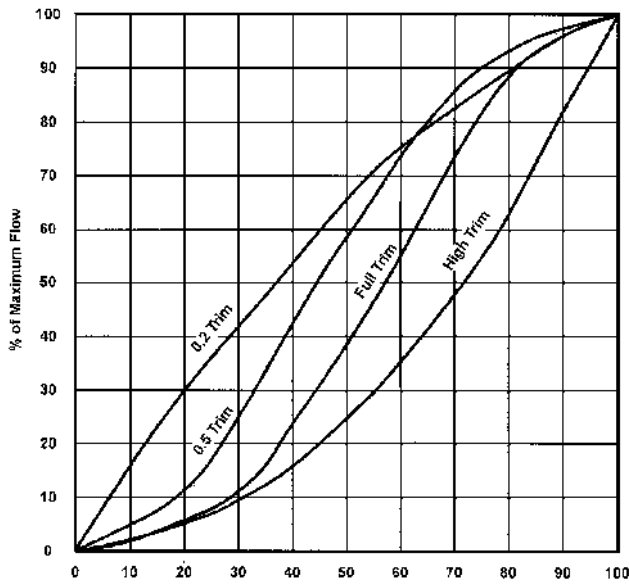

Flow Parameters

Valve Size	Cv*/Kv* 100% Open (Flow-to-Open)			
	High Trim	Full Trim	0.5 Trim	0.2 Trim
1" 25mm	17 14.7	14 12.1	7 6.1	3 2.6
1.5" 40mm	45 38.9	32 27.7	16 13.8	6 5.2
2" 50mm	85 73.5	50 43.3	25 21.6	10 8.7
2.5" 65mm	125 108.1	90 77.9	45 38.9	18 15.6
3" 80mm	185 160	150 129.8	75 64.9	30 26
4" 100mm	370 320.1	250 216.3	125 108.1	50 43.3
6" 150mm	800 692	525 454.1	260 224.9	105 90.8
8" 200mm	1400 1211	875 756.9	435 376.3	175 151.4
10" 250mm	2050 1773.3	1300 1124.5	600 519	260 224.9
12" 300mm	2600 2249	1750 1513.8	825 713.6	350 302.8

For Flow-to-Close values subtract 2%

Cv* = Flow in GPM of water at 1 psi pressure drop.
Kv* = Flow in m³/hr. of water at 100 kPa pressure drop.

Pressure Ratings

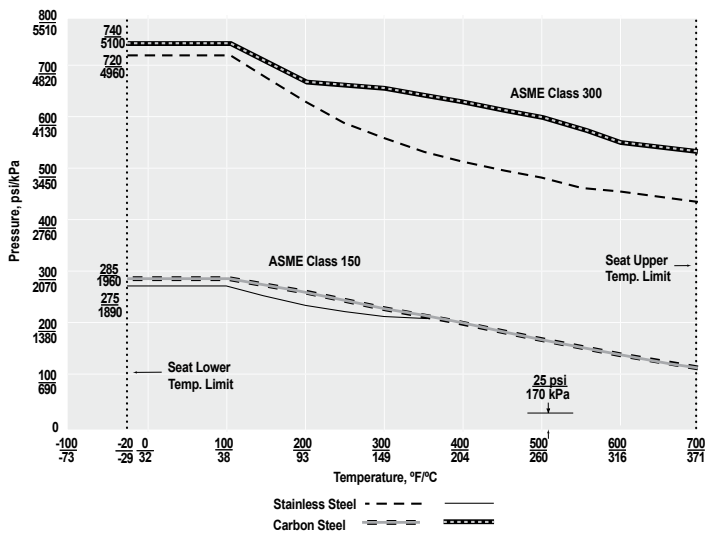

Shut-Off Capabilities

Seat Type	Flow Direction	Shut-Off Class (ANSI/FCI 70-2)
Rigid Metal	Bi-Directional	IV

Valve Weights (Excludes Titanium Design)

Valve Size	Class 150			Class 300
	Flanged	Flangeless	ASME (Long) Face-to-Face Flanged	Flanged
1" 25mm	12 5.4	9 4.1	13 5.9	15 6.8
1.5" 40mm	17 7.7	12 5.4	19 8.6	24 10.9
2" 50mm	21 9.5	13 5.9	24 10.9	27 12.2
2.5" 65mm	32 14.5	20 9.1	35 15.9	40 18.1
3" 80mm	47 21.3	35 15.9	50 22.7	58 26.3
4" 100mm	63 28.6	42 19.1	67 30.4	79 35.8
6" 150mm	95 43.1	74 33.6	106 48.1	142 64.4
8" 200mm	152 68.9	116 52.6	167 75.8	208 94.3
10" 250mm	236 107	182 82.5	254 115	342 155
12" 300mm	368 167	314 142	379 172	516 234

Pounds
Kilograms

ASME Body Rating/Face-to-Face

Class 150 Flanged 1-12" (25-300mm)	Flanged Class 150 ASME B16.10 ISO 5752 PN 10/16 EN 558-1 PN 10/16 Flanged Class 150 ISA 75.04 or IEC 534-3-2: Flanged Class 150 Long Body B16.10, ISO 5752 and EN 558-1PN 10/16
Class 150 Flangeless 1-12" (25-300mm)	Flangeless Class 150 ISA 75.04 or IEC 534-3-2
Class 300 Flanged 1-12" (25-300mm)	Flanged Class 300 ISA 75.04, IEC 534-3-2

Ordering

To order, simply complete the valve order code from information shown. An ordering example is shown for your reference.

Valve Style

Give valve style code as follows:

RCV = Rotary Control Valve

Valve Size

Give valve size code as follows:

1	=	1"	25mm	4	=	4"	100mm
1.5	=	1.5"	40mm	6	=	6"	150mm
2	=	2"	50mm	8	=	8"	200mm
2.5	=	2.5"	65mm	10	=	10"	250mm
3	=	3"	80mm	12	=	12"	300mm

End Connection

Give end connection code as follows:

Flangeless

W1S = Class 150, ASME/ISA 75.08.02 and IEC 534-3-2F-F
1-12" valves

Flanged

F1A = Class 150, ASME B16.10, ISO 5742 and EN558-1 PN 10/16
(long body), 1-12" excluding 2.5" valve size
F1S = Class 150, ASME/ISA 75.08.02 and IEC 534-3-2F-F
1-12" valves
F2S = Class 300, ASME/ISA 75.08.02 and IEC 534-3-2F-F
1-12" valves

Body Material

Give body material code as follows:

S2 = 316 stainless steel (Class 300 only)
S2 bodies must be ordered with S3 or S3S
plug, S5 or S10 shaft, and S3 or S3S seat
S3 = 317 stainless steel (Class 150 only)
S3 bodies must be ordered with S3 or S3S
plug, S10 shaft and S3 or S3S seat
CS = Carbon Steel, CS bodies must be ordered with S3 or
S3S plug, S5 or S10 shaft, and S3 or S3S seat
HC = Hastelloy C, HC body must be ordered with HC plug,
HCC or TNC shaft, HC seat, and HC, HCVS or HCKS bearings.
TN = Titanium (1"-8" only except 2-1/2")
TN body must be ordered with TN plug, TNC shaft,
TN seat, and TN or TNKS bearings.

Packing Material

Give body material code as follows:

TC = PTFE chevron, 500° F (260° C) Packing and Fluoro Rubber
(FKM) Seal
G2 = Braided carbon graphite, 1000° F (540° C) Packing and Nickel-
Chromium Alloy "C"

Trim Combination

Plug Material

Give plug & seat material code as follows:

S3 = 317 SST, electroless nickel coated, 800° F (427° C)
S3S = 317 SST with tungsten carbide overlay, 1000° F (538° C)
HC = Hastelloy C, 800° F (427° C)
TN = Titanium Anodized, 800° F (427° C)

Seat Material

Give plug & seat material code as follows:

S3 = 317 SST, electroless nickel coated, 800° F (427° C)
S3S = 317 SST with tungsten carbide overlay, 1000° F (538° C)
HC = Hastelloy C with Heat Treated Electroless Nickel overlay
800° F (427° C)
TN = Titanium Anodized, 800° F (427° C)

Trim Size

Give seating surface material code as follows:

H = High capacity
F = Full capacity
.5 = Reduced capacity
.2 = Reduced capacity

Shaft Material

Give seating surface material code as follows:

S10 = 2205 Duplex SST, 650° F (343° C), Class 150. On Class 300
1, 1.5, 3 & 10"
S5 = 17-4 pH SST. 800° F (427° C), Class 300 2, 4-8 & 12"
TNC = Titanium, Ceramic Coated, 800° F (427° C)
HCC = Hastelloy C Ceramic Coated, 800° F (427° C)

Bearing Material

Give seating surface material code as follows:

S9 = 440C Stainless Steel, 800° F (427° C)
S9VS = 440C Stainless Steel, PFA/fluoropolymer seal, 450° F (230° C)
SL = Solid Cobalt-Chromium alloy, 1000° F (538° C)
SLVS = Solid Cobalt-Chromium, PFA/fluoropolymer seal, 450° F
(232° C)
SLKS = Solid Cobalt-Chromium, FFKM/Perfluoroelastomer seal,
550° F (288° C)
HC = Hastelloy C, 1000° F (538° C)
HCVS = Hastelloy C, PFA/fluoropolymer seal, 450° F (232° C)
HCKS = Hastelloy C, FFKM/Perfluoroelastomer seal, 550° F (288° C)
TN = Titanium, 800° F (427° C)
TNKS = Titanium, FFKM/Perfluoroelastomer Seal, 550° F (288° C)

Options

Give option code as follows:

BAA = Buy American Act
CMC = Certificate of Material Conformance
CRT = Certified Physical and Chemical Test Reports
ST3 = Pennsylvania Steel Procurement Act
DTR = DeZURIK Std. Cert Production Hydrostatic Shell & Seat
Test Report
G1 = DIN 10 or BS4504/10 Drilling
G2 = DIN 16 or BS4504/16 Drilling
G3 = DIN 25 or BS4504/25 Drilling (F2S only)
G4 = DIN 40 or BS4504/40 Drilling (F2S only)
J1 = J1S 10 Flange Drilling (F1L or F1S only)
J6 = J1S 16 Flange Drilling (F1L or F1S only)
J2 = J1S 20 Flange Drilling (F2S only)

Ordering Example:

RCV,4,F1S,S3,TC,S3-S3S-F-S10-S9*PR-R1A-PC4

Dimensions

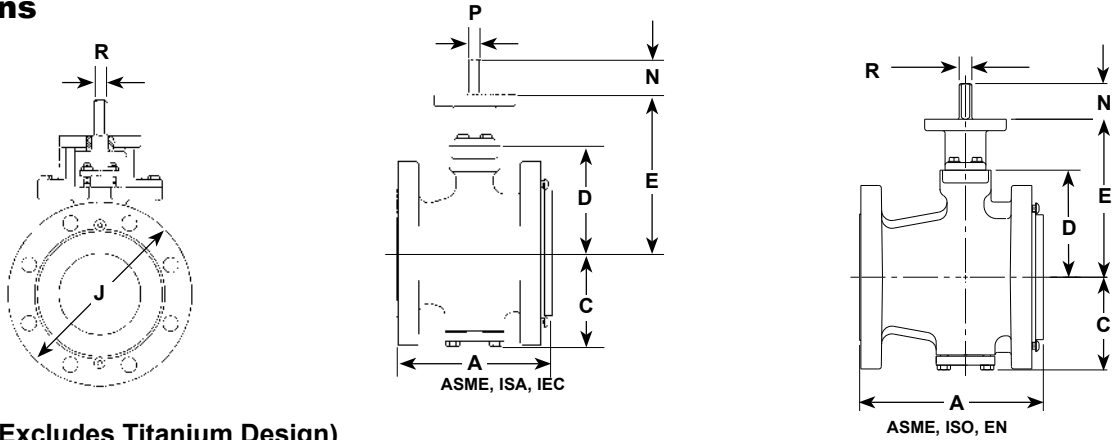

Basic Valve (Excludes Titanium Design)

Valve Size	A		C	D	E	J			N	R Diameter	P Square
	ISA IEC	ASME ISO EN				Flanged Class 150	Flangeless Class 150	Flanged Class 300			
1" 25mm	4.00 102	5.00 127	2.75 70	3.25 83	5.62 143	4.25 108	2.44 62	4.88 124	1.75 44	.62 16	.50 13
1.5" 40mm	4.50 114	6.50 165	2.94 75	3.47 88	5.84 148	5.00 127	3.06 78	6.12 155	1.75 44	.62 16	.50 13
2" 50mm	4.88 124	7.00 178	3.22 82	3.75 95	6.12 155	6.00 152	3.81 97	6.50 165	1.75 44	.62 16	.50 13
2.5" 65mm	5.50 140	7.50 191	3.75 95	4.44 113	6.94 176	7.00 178	4.38 111	7.50 190	1.75 44	.75 19	.62 16
3" 80mm	6.50 165	8.00 203	4.00 102	4.69 119	7.19 183	7.50 191	5.19 132	8.25 210	1.75 44	.75 19	.62 16
4" 100mm	7.62 194	9.00 229	4.56 116	5.25 133	7.75 197	9.00 229	6.38 162	10.00 254	1.75 44	.75 19	.62 16
6" 150mm	9.00 229	10.50 267	5.72 145	6.50 165	9.50 241	11.00 279	8.50 216	12.50 317	1.75 44	1.25 32	.94 24
8" 200mm	9.56 243	11.50 292	7.28 185	8.12 206	11.12 282	13.50 343	10.62 270	15.00 381	1.75 44	1.50 38	1.19 30
10" 250mm	11.69 297	13.00 330	8.91 226	9.50 241	13.38 340	16.00 406	13.12 333	17.50 444	1.75 44	2.00 51	1.62 41
12" 300mm	13.31 338	14.00 356	9.91 252	10.50 267	14.38 365	19.00 483	15.38 391	20.50 521	1.75 44	2.00 51	1.62 41

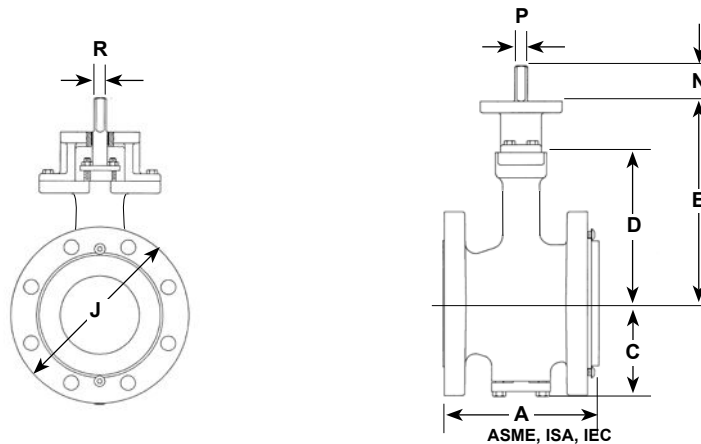

Basic Valve (Titanium Only Design)

Valve Size	A ISA IEC	C	D	E	J Flanged Class 150/300	N	R Diameter	P Square
1" 25mm	4.00 102	2.75 70	5.50 140	7.87 200	4.88 124	1.75 44	.62 16	.50 13
1.5" 40mm	4.50 114	2.94 75	5.72 145	8.09 205	6.12 155	1.75 44	.62 16	.50 13
2" 50mm	4.88 124	3.22 82	6.00 152	8.37 213	6.50 165	1.75 44	.62 16	.50 13
3" 80mm	6.50 165	4.00 102	7.00 178	9.50 241	8.25 210	1.75 44	.75 19	.62 16
4" 100mm	7.62 194	4.56 116	7.56 192	10.06 256	10.00 254	1.75 44	.75 19	.62 16
6" 150mm	9.00 229	5.72 145	9.00 229	12.00 305	12.50 317	1.75 44	1.25 32	.94 24
8" 200mm	9.56 243	7.28 185	10.50 267	13.50 343	15.00 381	1.75 44	1.50 38	1.19 30

Tie Bolt & Bolt Lengths Flangeless Valves

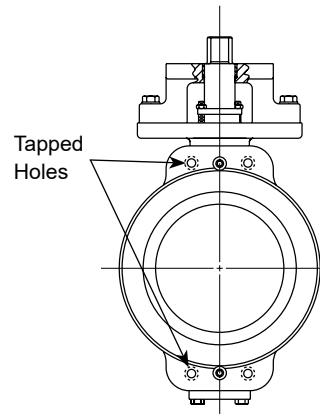
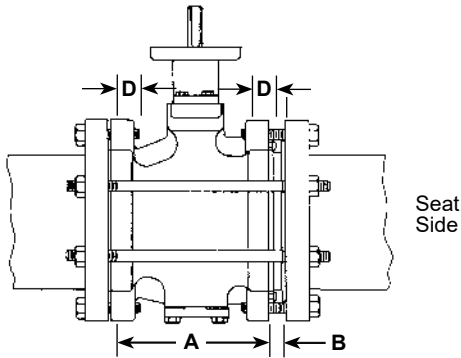

Valve Size	A	B	D
		ISA & IEC	
1" 25mm	3.69 94	.31 8	.44 11
1.5" 40mm	4.19 106	.31 8	.56 14
2" 50mm	4.57 116	.31 8	.62 16
2.5" 65mm	4.94 125	.56 15	.69 18
3" 80mm	5.94 151	.56 15	.75 19
4" 100mm	7.06 179	.56 15	.94 24
6" 150mm	8.50 216	.50 13	1 25
8" 200mm	9.06 230	.50 13	1.12 28
10" 250mm	11.07 281	.62 16	1.19 30
12" 300mm	12.69 322	.62 16	1.25 32

Valve Size	Quantity of Tapped Holes/Flange			
	ASME 150	PN 10	JIS 10	JIS 16
1" 25mm	-	-	-	-
1.5" 40mm	-	-	-	-
2" 50mm	-	-	-	4
2.5" 65mm	-	-	-	4
3" 80mm	-	-	4	4
4" 100mm	-	-	4	4
6" 150mm	-	-	-	4
8" 200mm	-	-	4	4
10" 250mm	4	4	4	4
12" 300mm	4	4	4	4

Tie Bolt Length

To determine the minimum tie bolt length on flangeless valves:

- add body length (dimension A from chart)
- add seat retainer length (dimension B from chart)
- add the two adjoining pipe flange thicknesses (customer determined)
- add the thicknesses of the two nuts (customer determined)

Bolt Length for Tapped Holes – Side Opposite Seat

To determine the minimum bolt length on flangeless valves for the side opposite the seat:

- add the tapped lug thickness (dimension D from chart)
- add the adjoining pipe flange thickness (customer determined)

Bolt Length for Tapped Holes – Seat Side

To determine the minimum bolt length on the seat side of flangeless valves:

- add the tapped lug thickness (dimension D from chart)
- add the seat retainer length (dimension B from chart)
- add the adjoining pipe flange thickness (customer determined)

Bolt Length for Tapped Holes – Side Opposite Seat

To determine the minimum bolt length on the side opposite the seat for those valves with tapped holes:

- add the valve flange thickness (dimension D from chart)
- add adjoining pipe flange thickness (customer determined)

Tie Bolt & Bolt Lengths Flanged Valves

Bolt Length for Tapped Holes – Seat Side

To determine the minimum bolt length on the seat side for those valves with tapped holes:

- add the valve flange thickness (dimension D from chart)
- add seat retainer length (dimension B from chart)
- add adjoining pipe flange thickness (customer determined)

Bolt Length – Side Opposite Seat

To determine the minimum bolt length on the side opposite the seat:

- add the valve flange thickness (dimension D from chart)
- add the adjoining pipe flange thickness (customer determined)
- add nut thickness (customer determined)

Bolt Length – Seat Side

To determine the minimum bolt length on the seat side of flanged valves:

- add the valve flange thickness (dimension D from chart)
- add seat retainer length (dimension B from chart)
- add adjoining pipe flange thickness (customer determined)
- add nut thickness (customer determined)

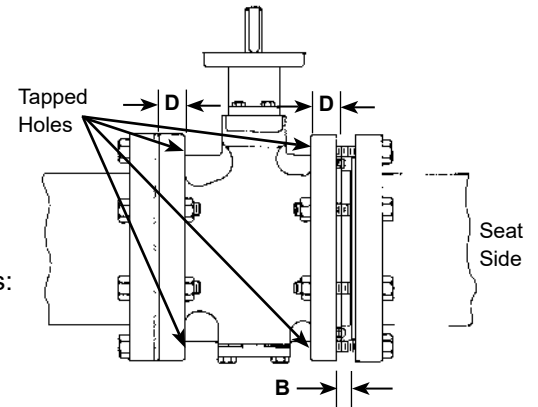

Bolt Lengths - Flanged Valves

Valve Size	Quantity of Tapped Holes/Flange					
	ASME 150	ASME 300	PN 10/16	PN 25/40	JIS 10	JIS 16/20
1" 25mm	-	-	-	-	4	4
1.5" 40mm	-	-	-	-	4	4
2" 50mm	-	4	-	-	4	4
2.5" 65mm	-	4	-	4	4	4
3" 80mm	-	-	-	-	8	4
4" 100mm	-	-	-	-	8	8
6" 150mm	-	4	-	-	8	4
8" 200mm	-	4	-	4	12	4
10" 250mm	-	-	-	-	12	-
12" 300mm	-	-	-	-	16	4

Valve Size	B	D Flanged Thickness	
		Class 150	Class 300
1" 25mm	0.31 8	.44 11	.69 18
1.5" 40mm	0.31 8	.56 14	.81 21
2" 50mm	0.31 8	.62 16	.88 22
2.5" 65mm	0.56 15	.69 18	1 25
3" 80mm	0.56 15	.75 19	1.12 28
4" 100mm	0.56 15	.94 24	1.25 32
6" 150mm	0.50 13	1 25	1.44 37
8" 200mm	0.50 13	1.12 28	1.62 41
10" 250mm	0.62 16	1.19 30	1.88 48
12" 300mm	0.62 16	1.25 32	2 51

Sales and Service

For information about our worldwide locations, approvals, certifications and local representative:

Web Site: DeZURIK.com E-Mail: info@DeZURIK.com



250 Riverside Ave. N. Sartell, Minnesota 56377 • Phone: 320-259-2000 • Fax: 320-259-2227

DeZURIK reserves the right to incorporate our latest design and material changes without notice or obligation. Design features, materials of construction and dimensional data, as described in this bulletin, are provided for your information only and should not be relied upon unless confirmed in writing by DeZURIK. Certified drawings are available upon request.