

# **APCO ARV CLEAN WATER AIR RELEASE VALVES**

## **BODY STYLES 50A AND 200A/200/205/206/207**



**Body Style 50A**  
0.5-1" (15-25mm)



**Body Style 200A**  
1-2" (25-50mm)



**Body Style 200**  
2-3" (50-80mm)



**Body Styles 205 High Pressure**  
2" (50mm)



**Body Styles 206 High Pressure**  
2" (50mm)



**Body Style 207**  
6" (150mm)

## Why Use Air Release Valves?

An Air Release Valve has a small venting orifice and is used whenever air is entrained in water under pressure. These pockets of air increase the resistance of water flow. In critical installations, air can reduce the capacity of a line down to zero. More common is an increased resistance of 10-15%. The increased resistance must be overcome by the pump using more power than necessary to move the required amount of water. Such a loss can continue unnoticed for years creating excessive power consumption costs. This is a major reason why all points where air can collect should be equipped with an APCO Air Release Valve.

The Air Release Valves have much smaller orifices than Air/Vacuum Valves. Their function is to release small pockets of air which gather at the high points of a system after it is filled and under pressure. The Air Release Valve has the ability to open against internal pressure because it has a small orifice and a leverage mechanism which multiplies the force of the float. This force must be greater than the internal pressure across the orifice in order to open it when a pocket of air needs to be vented. This explains why, as the internal pressure increases, the orifice decreases in size to facilitate the valve opening.

## Where to Install

Typical pipeline and position of necessary APCO air valves

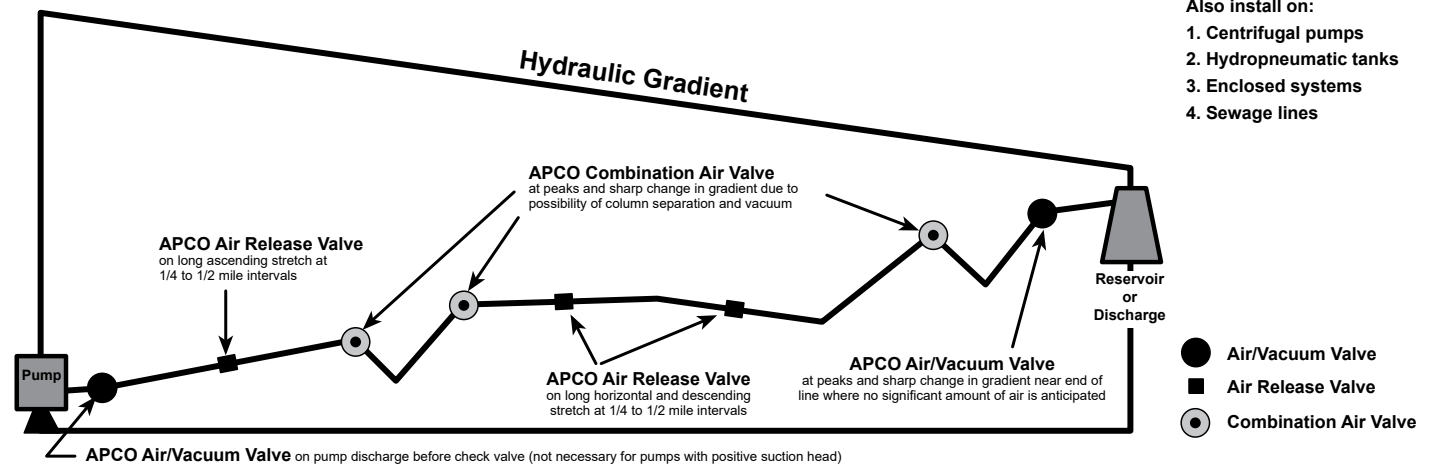

## Design & Construction

The Air Release Valve consists of a body, cover, needle, seat and stainless steel float.

The following body styles are available:

- ARV Air Release Valve Body Style 50A**  
 The APCO Air Release Valves in Body Style 50A, in sizes .5-1" (15-25mm), are available in ductile iron bodies with a threaded NPT inlet and outlet as standard and FM Approved.
- ARV Air Release Valve Body Styles 200A/200/205/206/207**  
 The APCO Air Release Valves in Body Styles 200A/200/205/206/207 in sizes 1-6" (25-150mm), with ASME 125/150 or 250/300 flanged inlets and a NPT outlet or threaded inlet and outlet as standard. Threaded or flanged outlets are available for valves used inside a pump house.

Refer to APCO Air Valve Selection & Sizing Guide, Bulletin 610, for Air/Vacuum Valve sizing data and formulas.

# Options & Accessories

## Mushroom Cap (MRC)

Mushroom Caps are available as an option on .5-3" (15-75mm) valves. They are installed in the threaded outlet for discharge protection.

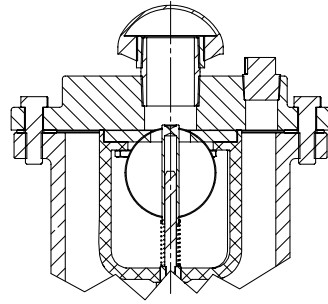

Mushroom Cap (MRC)

## Air Out - No Air In External Check (AEC)

External check valves are available as an option on .5-6" (15-150mm) valves. They are installed in the threaded outlet for inflow protection.

# Materials of Construction

## Body Style 50A

Item	Description	Material
R01	Body	Ductile Iron, ASTM A536, Grade 65-45-12 Stainless Steel, CF-8M, ASTM A351
R02	Cover	Ductile Iron, ASTM A536, Grade 65-45-12 Stainless Steel, CF-8M, ASTM A351
R03	Cover Gasket	Interface CS-301
R04	Cover Bolts	Carbon Steel, ASTM A449, Grade 5, SAE J429 316 Stainless Steel
R05	Lever Frame	316 Stainless Steel, ASTM A276
R06	Seat	316 Stainless Steel, ASTM A276
R07	Needle	Acrylonitrile-Butadiene Ethylene, Propylene, & Diene Terpolymer Fluoro Rubber
R08	Lever Pin	316 Stainless Steel, ASTM A276
R09	Float Lever	316 Stainless Steel, ASTM A276
R10	Float	316 Stainless Steel, ASTM A276
R11	Pin Retainer	632 Stainless Steel, ASTM A564/A693 316 Stainless Steel
R12	Washer	Carbon Steel, Zinc Plated 316 Stainless Steel

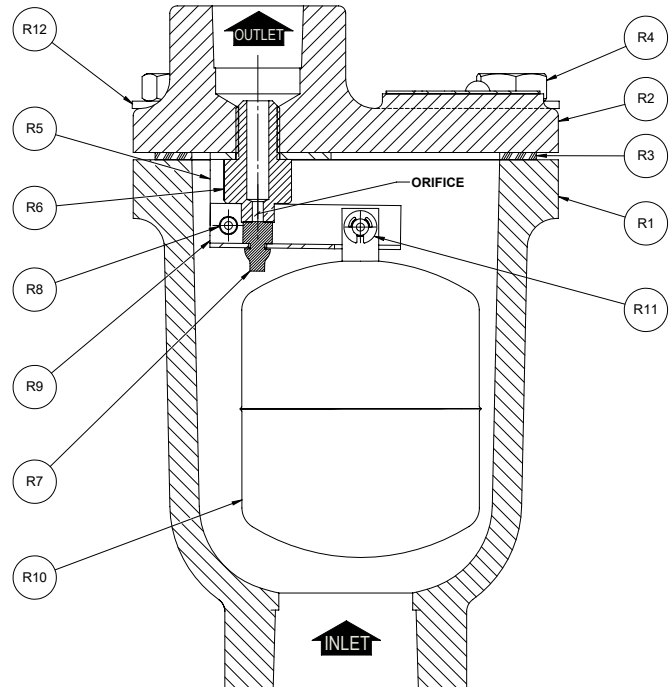

# Materials of Construction

## Body Style 200A

Item	Description	Material
R01	Body	Ductile Iron, ASTM A536, Grade 65-45-12
		Bronze, ASTM B505/B427
		Stainless Steel, CF-8M, ASTM A351
R02	Cover	Ductile Iron, ASTM A536, Grade 65-45-12
		Bronze, ASTM B505/B427
		Stainless Steel, CF-8M, ASTM A351
R03	Cover Gasket	Interface CS-301
R04	Cover Bolts	Carbon Steel, Zinc Plated
		Brass
R05	Leverage Frame	316 Stainless Steel
R06	Seat	Stainless Steel, CF-8M, ASTM A743
R07	Needle	316 Stainless Steel, ASTM A276
R09	Needle Lever	Acrylonitrile-Butadiene
		Ethylene, Propylene, & Diene Terpolymer
R10	Lever Pin	Fluoro Rubber
R11	Pin Retainer	Stainless Steel, CF-8M, ASTM A743
R12	Connecting Link	316 Stainless Steel, ASTM A276
R13	Float Lever	632 Stainless Steel, ASTM A564/A693
R14	Float	316 Stainless Steel, ASTM A276
R15	Pipe Plug	316 Stainless Steel, ASTM A276
		Steel, SAE J502
		Bronze, ASTM B61
R16	Washer	316 Stainless Steel
		Carbon Steel, Zinc Plated
R38	Float Spud	316 Stainless Steel, ASTM A276

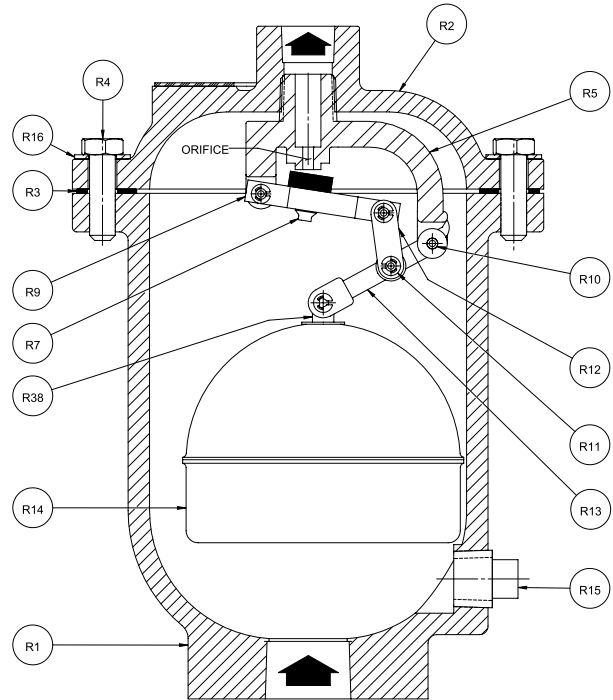

## Body Style 200

Item	Description	Material
R01	Body	Ductile Iron, ASTM A536, Grade 65-45-12
		Bronze, ASTM B505/B427
		Stainless Steel, CF-8M, ASTM A351
R02	Cover	Ductile Iron, ASTM A536, Grade 65-45-12
		Bronze, ASTM B505/B427
		Stainless Steel, CF-8M, ASTM A351
R03	Cover Gasket	Interface CS-301
R04	Cover Bolts	Carbon Steel, ASTM A449, Grade 5
		Brass
R05	Leverage Frame	316 Stainless Steel
R06	Seat	Stainless Steel, CF-8M, ASTM A351
R07	Needle	316 Stainless Steel, ASTM A276
		Acrylonitrile-Butadiene
R09	Needle Lever	Ethylene, Propylene, & Diene Terpolymer
R10	Lever Pin	Fluoro Rubber
R11	Retaining Ring	Stainless Steel, CF-8M, ASTM A351
R12	Connecting Link	316 Stainless Steel, ASTM A276
R13	Float Lever	632 Stainless Steel, ASTM A564/A693
R14	Float	316 Stainless Steel, ASTM A276
R15	Leverage Frame Gasket	316 Stainless Steel, ASTM A276
R16	Leverage Frame Screw	Cellulose Cork Fiber
R17	Leverage Frame Washer	316 Stainless Steel
R18	Drain Pipe Plug	Steel Alloy, SAE J502
		Bronze, ASTM B61
		316 Stainless Steel
R19	Pipe Plug	Iron, ASTM A197
		Bronze, ASTM B61
		316 Stainless Steel
R20	Flat Washer	Carbon Steel, Zinc Plated
R97	Data Plate	316 Stainless Steel
R98	Drive Screws	18-8 Stainless Steel

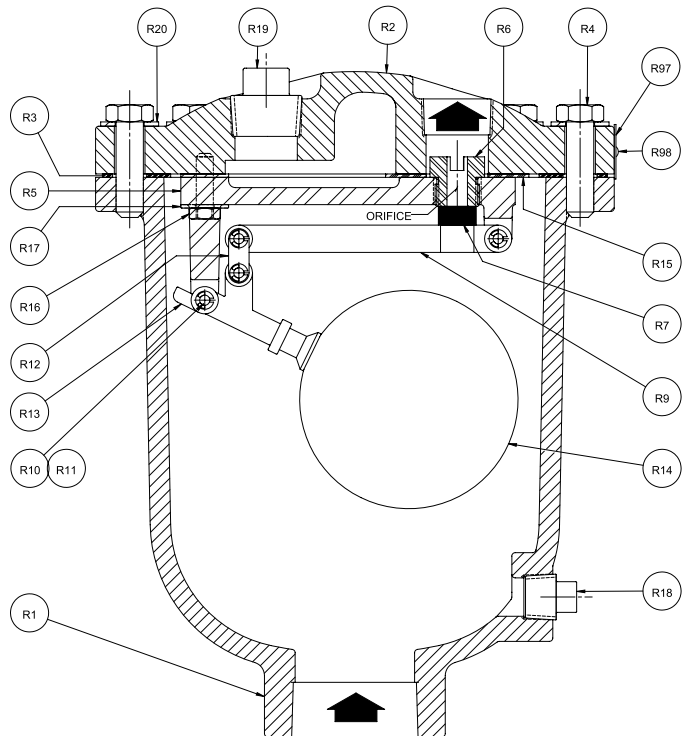

# Materials of Construction

## Body Style 200

Item	Description	Material
R01	Body	Ductile Iron, ASTM A536, Grade 65-45-12
		Bronze, ASTM B505/B427
		Stainless Steel, CF-8M, ASTM A351
R02	Cover	Ductile Iron, ASTM A536, Grade 65-45-12
		Bronze, ASTM B505/B427
R03	Cover Gasket	Interface CS-301
		Carbon Steel, ASTM A449, Grade 5
R04	Cover Bolts	Brass
		316 Stainless Steel
R05	Leverage Frame	Stainless Steel, CF-8M, ASTM A351
R06	Seat	316 Stainless Steel, ASTM A276
R07	Needle	Acrylonitrile-Butadiene
		Ethylene, Propylene, & Diene Terpolymer
		Fluoro Rubber
R09	Needle Lever	Stainless Steel, CF-8M, ASTM A351
R10	Lever Pin	316 Stainless Steel, ASTM A276
R11	Retaining Ring	632 Stainless Steel, ASTM A564/A693
		316 Stainless Steel, ASTM A276
R12	Connecting Link	316 Stainless Steel, ASTM A276
R13	Float Lever	Stainless Steel, CF-8M, ASTM A351
R14	Float	316 Stainless Steel, ASTM A240/A276
R15	Leverage Frame Gasket	Cellulose Cork Fiber
R16	Leverage Frame Screw	316 Stainless Steel
R17	Leverage Frame Washer	316 Stainless Steel
R18	Drain Pipe Plug	Steel Alloy, SAE J502
		Bronze, ASTM B61
		316 Stainless Steel
R19	Pipe Plug	Iron, ASTM A197
		Bronze, ASTM B61
		316 Stainless Steel
R20	Flat Washer	Carbon Steel, Zinc Plated
		316 Stainless Steel
R97	Data Plate	316 Stainless Steel
R98	Drive Screws	18-8 Stainless Steel

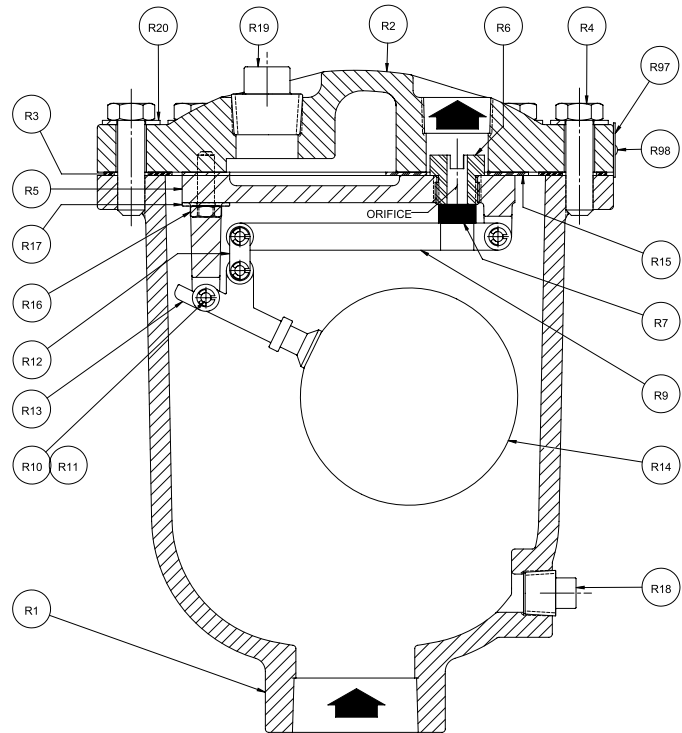

## Body Style 205

Item	Description	Material
R01	Body	Ductile Iron, ASTM A536, Grade 65-45-12
		Carbon Steel, ASTM A216
		Stainless Steel, CF-8M, ASTM A351
R02	Cover	Ductile Iron, ASTM A536, Grade 65-45-12
		Carbon Steel, ASTM A216
R03	Cover Gasket	Fiber with elastomer binder
		Carbon Steel, Zinc Plated
R04	Cover Bolts	316 Stainless Steel
R05	Leverage Frame	Stainless Steel, CF-8M, ASTM A351
R06	Seat	316 Stainless Steel, ASTM A276
R07	Needle	316 Stainless Steel, ASTM A276
R09	Needle Lever	Stainless Steel, CF-8M, ASTM A351
R10	Lever Pin	316 Stainless Steel, ASTM A276
R11	Retaining Ring	316 Stainless Steel, ASTM A276
R12	Connecting Link	316 Stainless Steel, ASTM A276
R13	Float Lever	Stainless Steel, CF-8M, ASTM A351
R14	Float	316 Stainless Steel, ASTM A240/A276
R15	Frame Seal	Acrylonitrile-Butadiene
R16	Bolt	316 Stainless Steel
R17	Washer	316 Stainless Steel
R25	Drain Plug	Steel Alloy, SAE J502
R26	Pipe Plug	316 Stainless Steel
R27	Washer	Carbon Steel, Zinc Plated
		316 Stainless Steel
R97	Data Plate	316 Stainless Steel
R98	Drive Screws	18-8 Stainless Steel

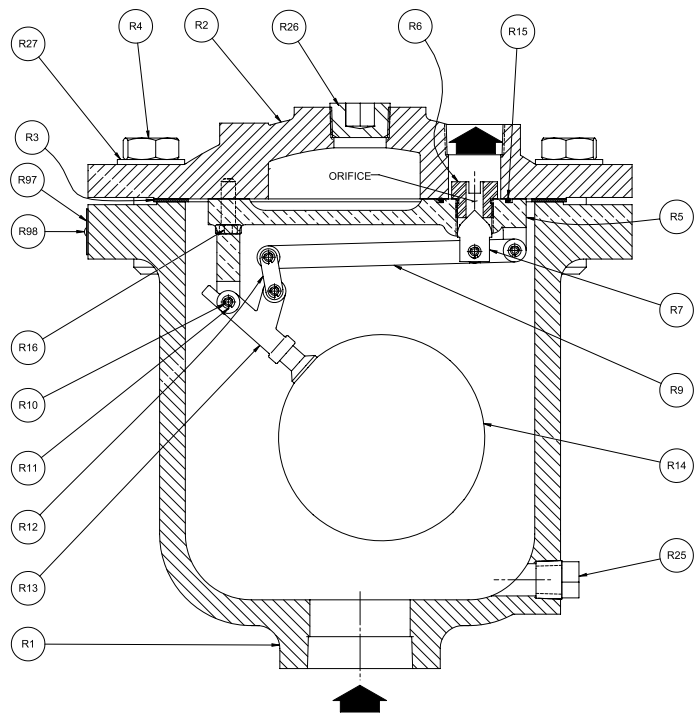

# Materials of Construction

## Body Style 206

Item	Description	Material
R01	Body	Ductile Iron, ASTM A536, Grade 65-45-12 Carbon Steel, ASTM A216 Stainless Steel, CF-8M, ASTM A351
R02	Cover	Ductile Iron, ASTM A536, Grade 65-45-12 Carbon Steel, ASTM A216 Stainless Steel, ASTM A743
R03	Cover Gasket	Fiber with elastomer binder
R04	Cover Bolts	Steel, ASTM A449, Grade 5 316 Stainless Steel
R05	Leverage Frame	Stainless Steel, CF-8M, ASTM A351
R06	Seat	316 Stainless Steel, ASTM A276
R07	Needle	316 Stainless Steel, ASTM A276
R09	Needle Lever	Stainless Steel, CF-8M, ASTM A351
R10	Lever Pin	316 Stainless Steel, ASTM A276
R11	Retaining Ring	632 Stainless Steel, ASTM A564/A693 316 Stainless Steel, ASTM A276
R12	Connecting Link	316 Stainless Steel, ASTM A276
R13	Float Lever	Stainless Steel, CF-8M, ASTM A351
R14	Float	316 Stainless Steel, ASTM A240/A276
R15	Frame Seal	Acrylonitrile-Butadiene
R16	Bolt	316 Stainless Steel
R17	Washer	316 Stainless Steel
R25	Pipe Plug	Steel Alloy, SAE J502 316 Stainless Steel
R26	Washer	Carbon Steel, Zinc Plated 316 Stainless Steel
R97	Data Plate	316 Stainless Steel
R98	Drive Screws	18-8 Stainless Steel

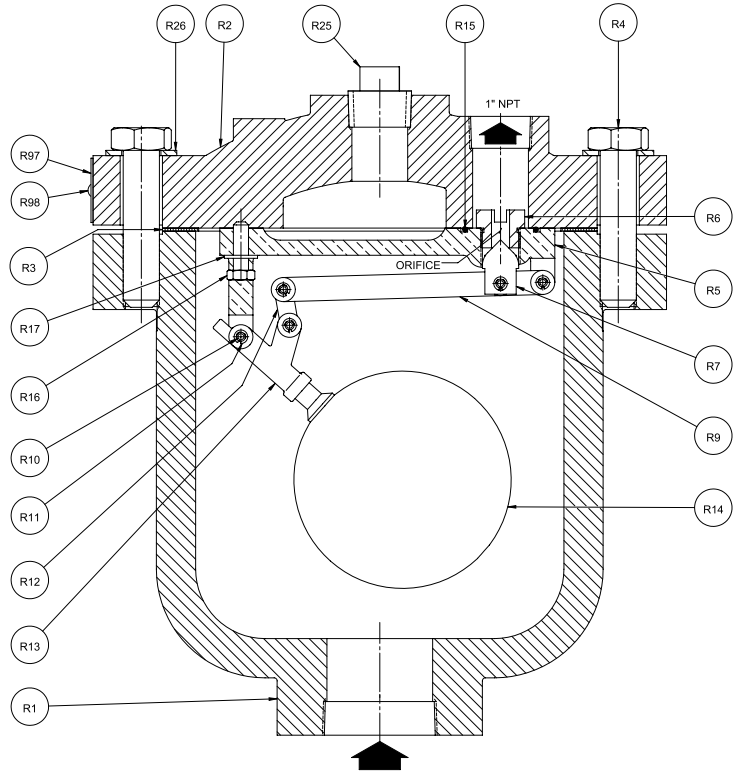

## Body Style 207

Item	Description	Material
R01	Body	Ductile Iron, ASTM A536, Grade 65-45-12
R02	Cover	Ductile Iron, ASTM A536, Grade 65-45-12
R03	Cover Gasket	Cellulose Cork Fiber
R04	Cover Bolts	Carbon Steel, Zinc Plated 316 Stainless Steel
R05	Bracket (Short)	316 Stainless Steel, ASTM A276
R06	Seat	Acrylonitrile-Butadiene
R07	Screw	316 Stainless Steel
R08	Seat Retainer	316 Stainless Steel, ASTM A276
R09	Needle Pin	316 Stainless Steel, ASTM A276
R10	Needle Lever	316 Stainless Steel, ASTM A276
R11	Link	316 Stainless Steel, ASTM A276
R12	Bracket (Long)	316 Stainless Steel, ASTM A276
R13	Lever Pin	316 Stainless Steel, ASTM A276
R14	Pin Retainer	632 Stainless Steel, ASTM A564/A693
R15	Float Lever	316 Stainless Steel, ASTM A276
R16	Bumper	Acrylonitrile-Butadiene
R17	Bumper Screw	316 Stainless Steel
R18	Bumper Washer	316 Stainless Steel
R19	Float	316 Stainless Steel, ASTM A276
R20	Needle	316 Stainless Steel, ASTM A276
R21	Pipe Plug	Steel Alloy, SAE J502
R22	Washer	Carbon Steel, Zinc Plated 316 Stainless Steel
R97	Data Plate	316 Stainless Steel
R98	Drive Screws	18-8 Stainless Steel

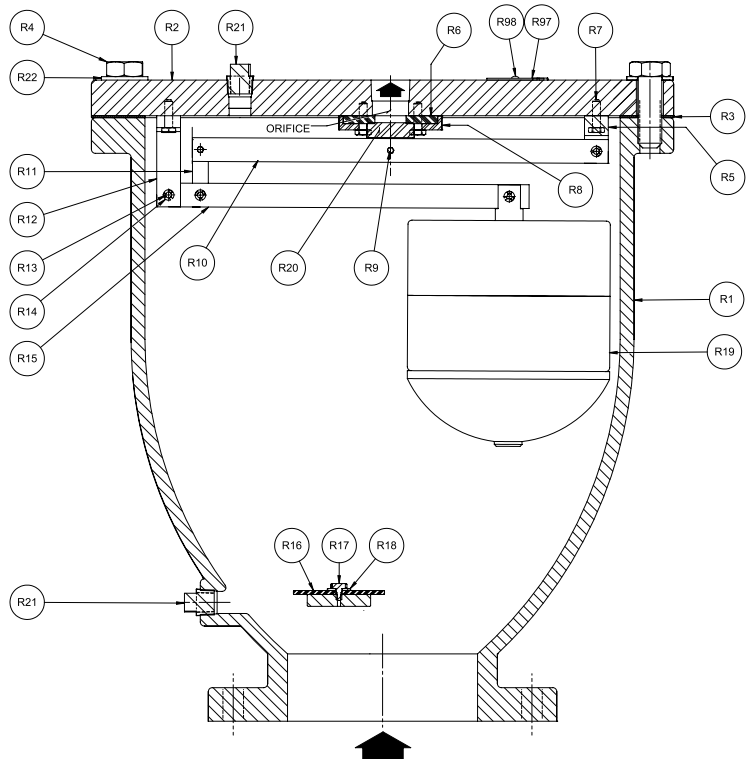



# Valve Selection

## Applicable Standards

<b>APCO AVV Air/Vacuum Valves are designed and/or tested to meet the following standards:</b>	
AWWA C-512	Air-Release, Air/Vacuum, and Combination Air Valves for Waterworks Service
ASME B16.5	F1/ASME Class 150 & F2/ASME Class 300 style flanged valves made from carbon steel or stainless steel.
ASME B16.42	F1/ASME Class 150 & F2/ASME Class 300 style flanged valves made from ductile iron.

## Valve Sizing

Refer to the APCO Valve Selection & Sizing Guide, Bulletin 610, for Air/Vacuum and Air Relieve Valve orifice sizing and formulas.

Refer to Bulletin 613 for details on APCO Surge Check Valves for Slow Closing.

# Ordering

Orders should specify quantity and order code identification, in proper sequence, as shown.

## Valve Style

### Give valve style code as follows:

ARV = Air Release Valves<sup>(1)(2)</sup>

## Valve Size

### Give valve size code as follows:

.5	=	.5"	(15mm)	2	=	2"	(50mm)
.75	=	.75"	(20mm)	3	=	3"	(80mm)
1	=	1"	(25mm)	6	=	6"	(150mm)

## Body Style

### Give body style code as follows:

50A<sup>(3)</sup> = Series 50A (FM Approved or UL Listed with DI Body Material Only) 1" NPT Inlet, (Adaptable to 0.5 & 0.75" inlet with included bushings) 0.5" NPT Outlet  
 200A = Series 200A 1 or 2" NPT Inlet 0.5" NPT Outlet  
 200 = Series 200 2 or 3" NPT Inlet, 1" NPT Outlet  
 205 = Series 205 2" NPT Inlet, 1" NPT Outlet  
 206 = Series 206 2" NPT Inlet, 1" NPT Outlet (Pressure to 1500 PSI)  
 207 = Series 207 6" Inlet, 3/4" or 1" NPT Outlet (Determined by orifice size)

## End Connection

### Give inlet connection code as follows:

T1 = Threaded Inlet NPT (0.5-3" all Body Styles except 207)  
 F1N = Flanged Inlet, ASME 125/150, Nipple & Flange (1,2&3" Styles 200A, 200 & 205)  
 F1 = Flanged Inlet, ASME 125/150 (6" Style 207) Cast  
 F2N = Flanged Inlet, ASME 250/300, Nipple & Flange (2&3" Body Styles 200 & 205)  
 F2 = Flanged Inlet, ASME 250/300 (6" Body Style 207) Cast  
 F4N = Flanged Inlet, ASME 400, Nipple & Flange (2" Body Styles 205 & 206)  
 F6N = Flanged Inlet, ASME 600, Nipple & Flange (2" Body Styles 205 & 206)

## Body Material

### Give body material code as follows:

BRZ = Bronze (Body Styles 200A & 200)  
 DI = Ductile Iron (except Body Style 206)  
 CS = Carbon Steel (Body Styles 205 & 206)  
 S2 = 316 Stainless Steel (except Body Style 207)

### Notes:

- Maximum operating temperature is a function of the materials used in the valve. All valves are rated to a maximum temperature of at least 180° F (82° C). Contact Application Engineering if the valve is required to operate above this temperature.
- For Seawater and Corrosive service, contact Application Engineering.
- See table for limited order code selections for style 50A.
- Body Style 50A with R116 orifice size is FM Approved, with R332 UL Listed and FM Approved.
- S2 Body Material has SB16 bolting as standard. Available with 200A, 200, 205, 206 & 207. Not available with 50A.

## Trim Combination

### Orifice Size

### Give orifice size code as follows:

**Body Style 50A<sup>(4)</sup>**  
 R332 = 3/32" 8-175 psi (Standard)  
 R116 = 1/16" 11-300 psi  
**Body Style 200A**  
 L516 = 5/16" 3-15 psi  
 R516 = 5/16" 11-50 psi  
 R14 = 1/4" 11-75 psi  
 R316 = 3/16" 11-150 psi (Standard)  
 R532 = 5/32" 11-300 psi  
 M332 = 3/32" 11-600 psi (DI, CS or S2 Body materials)

### Body Style 200

L12 = 1/2" 3-15 psi  
 R12 = 1/2" 11-75 psi  
 R38 = 3/8" 51-150 psi (Standard)  
 M732 = 7/32" 51-300 psi

### Body Style 205

H12 = 1/2" 50-100 psi  
 H38 = 3/8" 50-150 psi  
 H732 = 7/32" 50-500 psi (Standard)  
 H18 = 1/8" 50-800 psi

### Body Style 206

H332 = 3/32" 50-1500 psi

### Body Style 207

L1 = 1" 3-15 psi  
 R1 = 1" 11-150 psi (Standard)  
 R75 = 3/4" 11-300 psi

Note: Limiting factor for working pressure is lowest pressure rating of end connection or orifice size.

## Needle Material

### Give needle material code as follows:

#### Body Styles 50A

NBR = Acrylonitrile-Butadiene  
 EPDM = Terpolymer of Ethylene Propylene & A Diene, Body Material S2 only  
 FKM = Fluoro Rubber. For use only with S2 Body Material. (On Application)

#### Body Styles 200A & 200

NBR = Acrylonitrile-Butadiene  
 EPDM = Terpolymer of Ethylene Propylene & A Diene  
 FKM = Fluoro Rubber (On Application)

#### Body Styles 205, 206, 207

S2 = 316 Stainless Steel

## Seat Material

### Give seat material code as follows:

NBR = Acrylonitrile-Butadiene (Body Style 207)  
 S2 = 316 Stainless Steel (Except Body Style 207)

## Float Material

### Give float material code as follows:

S2 = 316 Stainless Steel

## Float Lever/Leverage Frame

### Give material code as follows:

S2 = 316 Stainless Steel

## Options

### Give option code as follows if required:

DTR = DeZURIK Standard Certified Production Hydrostatic Shell & Seat Test Report  
 SB16 = 316 Stainless Steel Bolting<sup>(5)</sup>  
 ---- = Special Coatings, Contact DeZURIK

## Accessories

### Give accessory code as follows if required:

AEC = Air Out - No In External Check  
 MRC = Mushroom Cap (All Body Styles except 207)

## Ordering Example:

ARV,1,200A,T1,DI,R316-NBR-S2-S2-S2\*MRC



# Dimensions

## Body Style 50A

Valve Size	A	B
0.5" 15mm	3.63 92	5.81 148
0.75" 20mm	3.63 92	5.81 148
1" 25mm	3.63 92	5.81 148

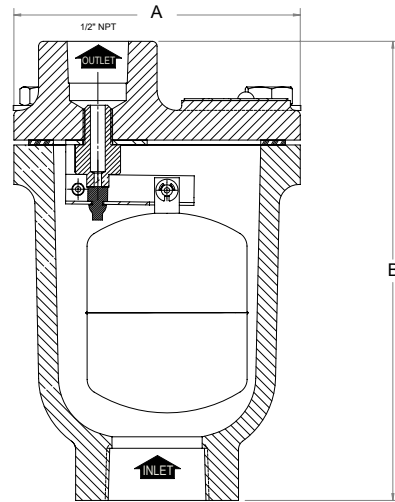

## Body Style 200A

Valve Size	A	B	C	D
1" 25mm	6.88 175	10.88 276	0.5 15	4.25 108
2" 50mm	6.88 175	11.63 295	0.69 18	6.00 150

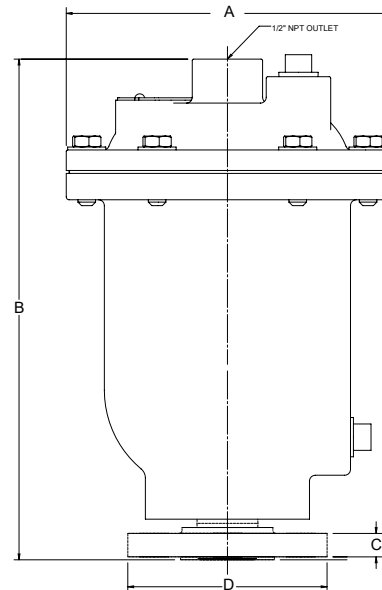

## Body Style 200 F1N End Connection

Valve Size	A	B	C	D
2" 50mm	9.50 241	14.38 365	0.69 18	6.00 152
3" 80mm	9.50 241	15.75 400	0.88 22	7.50 191

## F2N End Connection

Valve Size	A	B	C	D
2" 50mm	9.50 241	14.51 396	0.81 21	6.50 165
3" 80mm	9.50 241	15.94 405	1.06 27	8.25 210

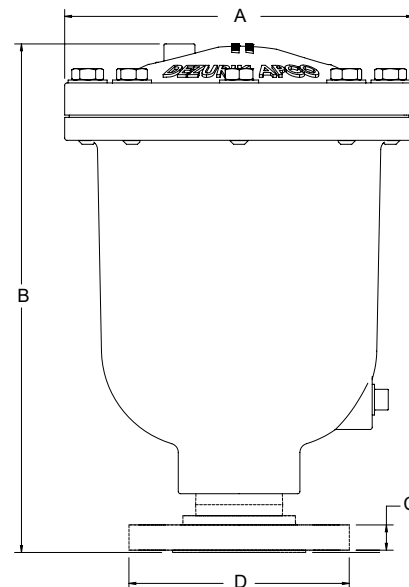

# Dimensions

## Body Style 205 F1N End Connection

Valve Size	A	B	C	D
2" 50mm	11.88 302	14.54 369	0.69 18	6.00 150

## F2N End Connection

Valve Size	A	B	C	D
2" 50mm	11.88 302	14.85 377	0.81 21	6.50 165

## F4N & F6N End Connections

Valve Size	A	B	C	D
2" 50mm	11.88 302	15.04 382	1.00 25	6.50 165

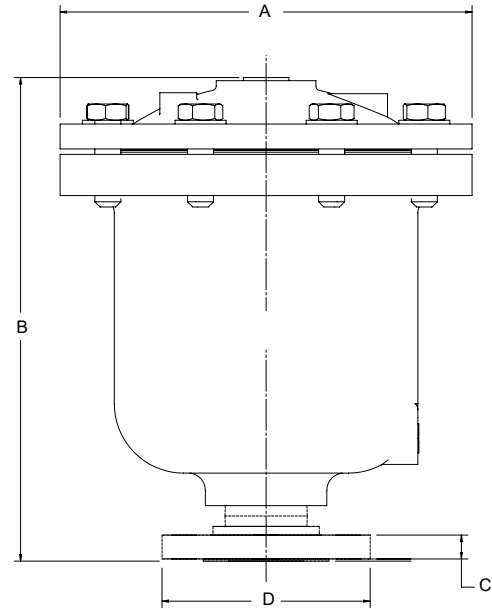

## Body Style 206 F4N & F6N End Connections

Valve Size	A	B	C	D
2" 50mm	11.88 302	15.47 393	1.00 25	6.50 165

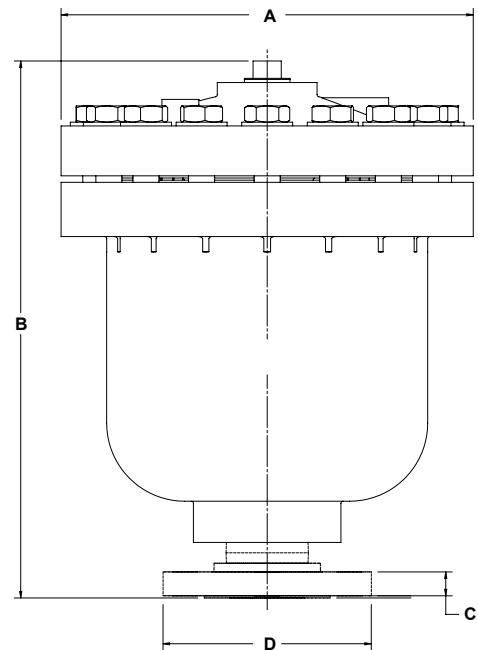

# Dimensions

## Body Style 207

### F1 End Connection

Valve Size	A	B	C	D
6" 150mm	$\frac{18.38}{467}$	$\frac{20.81}{529}$	$\frac{1.00}{25}$	$\frac{11.00}{279}$

### F2 End Connection

Valve Size	A	B	C	D
6" 150mm	$\frac{18.38}{467}$	$\frac{20.81}{529}$	$\frac{1.44}{37}$	$\frac{12.50}{318}$

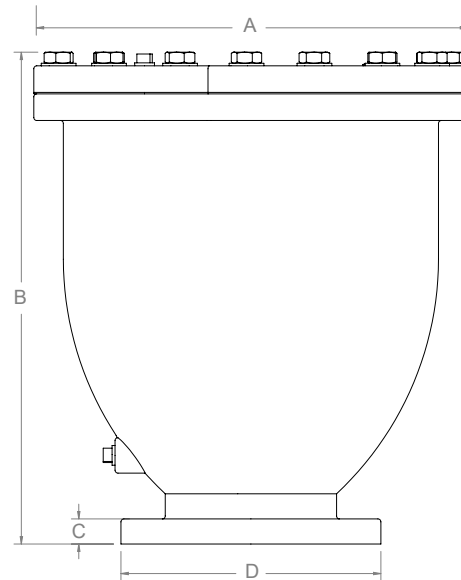

## Sales and Service

For information about our worldwide locations, approvals, certifications and local representative:

Web Site: [DeZURIK.com](http://DeZURIK.com) E-Mail: [info@dezurik.com](mailto:info@dezurik.com)



250 Riverside Ave. N. Sartell, Minnesota 56377 • Phone: 320-259-2000 • Fax: 320-259-2227

*DeZURIK, Inc. reserves the right to incorporate our latest design and material changes without notice or obligation. Design features, materials of construction and dimensional data, as described in this bulletin, are provided for your information only and should not be relied upon unless confirmed in writing by DeZURIK, Inc. Certified drawings are available upon request.*